

# Caminetti

Fireplaces - Cheminées  
Kamine - Chimeneas



P.2	<b>Piazzetta Total Comfort</b>
P.4	<b>Passione Accesa da oltre 50 anni</b>
P.6	<b>Prodotti fatti per durare nel tempo</b>
P.8	<b>Maiolica artigianale</b>
P.10	<b>Rivestimenti: i Veneziani</b>
P.12	<b>Linea Basic</b>
P.14	<b>Linee Elegance e Luxury</b>
P.16	<b>Le Terre</b>
P.18	<b>Colori</b>
P.22	<b>Rivestimenti</b>
P.176	<b>Colori e finiture</b>

P.180	<b>Abbinamenti</b>
P.182	<b>Tecnologia: i focolari</b>
P.184	<b>Combustibili</b>
P.186	<b>Multifuoco® System</b>
P.192	<b>Caratteristiche</b>
P.196	<b>Focolari</b>
P.232	<b>Thermo Solutions</b>
P.240	<b>Tabelle di compatibilità</b>
P.246	<b>Legenda</b>
P.251	<b>Index</b>

<u>EN</u>	
P.2	Piazzetta Total Comfort
P.4	A burning passion for over 50 years
P.6	Products that endure time
P.8	Handcrafted Majolica
P.10	Surrounds: i Veneziani
P.12	Basic range
P.14	Elegance and Luxury ranges
P.16	Clay
P.18	Colours
P.22	Surrounds
P.176	Colours and finishes
P.180	Combinations
P.182	Technology: fireboxes
P.184	Fuels
P.186	Multifuoco® System
P.192	Characteristics
P.196	Fireboxes
P.232	Thermo Solutions
P.240	Compatibility tables
P.246	Key
P.251	Index

<u>FR</u>	
P.2	Piazzetta Total Comfort
P.4	Passion enflammée depuis plus de 50 ans
P.6	Des produits faits pour durer dans le temps
P.8	Faïence artisanale
P.10	Revêtements : i Veneziani
P.12	Ligne Basic
P.14	Lignes Elegance et Luxury
P.16	Les Terres
P.18	Couleurs
P.22	Revêtements
P.176	Couleurs et finitions
P.180	Associations
P.182	Technologie : les monoblocs
P.184	Combustibles
P.186	Multifuoco® System
P.192	Caractéristiques
P.196	Monoblocs
P.232	Thermo Solutions
P.240	Tableaux de compatibilité
P.246	Légende
P.251	Index

<u>DE</u>	
Piazzetta Total Comfort	
Brennendes Feuer seit über 50 Jahren	
Produkte, die Jahrzehnte überdauern	
Handwerkliche Fertigung	
Verkleidungen: i Veneziani	
Basic-Linie	
Linien Elegance und Luxury	
Die Erden	
Farben	
Verkleidungen	
Farben und Oberflächen	
Kombinationen	
Technologie: Heizeinsätze	
Brennstoffe	
Multifuoco® System	
Eigenschaften	
Heizeinsätze	
Thermo Solutions	
Kompatibilitätstabellen	
Legende	
Index	

<u>ES</u>	
Piazzetta Total Comfort	
Pasión encendida desde hace más de 50 años	
Productos hechos para durar a lo largo del tiempo	
Mayólica artesanal	
Revestimientos: i Veneziani	
Línea Basic	
Líneas Elegance y Luxury	
Las Tierras	
Colores	
Revestimientos	
Colores y acabados	
Combinaciones	
Tecnología: monobloques	
Combustibles	
Multifuoco® System	
Características	
Monobloques	
Thermo Solutions	
Tablas de compatibilidad	
Leyenda	
Index	

**Copyright © 2018. Tutti i diritti sul catalogo, sulle immagini ed i testi, marchi e segni distintivi sono riservati e di proprietà di Gruppo Piazzetta s.p.a. . Sono vietate la riproduzione e diffusione, anche parziale, in qualsiasi forma, e/o l'uso non autorizzato. L'azienda ha facoltà, nel perfezionare i prodotti, a variare le caratteristiche tecniche ed estetiche. I modelli possono variare da Paese a Paese.**

EN Copyright © 2018. All rights of the catalog, images and texts, trademarks and distinctive labels are reserved and owned by Gruppo Piazzetta s.p.a. . Reproduction and distribution, in whole or in part, in any form, and / or unauthorized use are prohibited. The company has the faculty, in perfecting the products, to vary the technical and design characteristics. Models may vary from country to country.

FR Copyright © 2018. Tous les droits sur le catalogue, sur les images et les textes, marques et signes distinctifs sont réservés et sont la propriété du Gruppo Piazzetta s.p.a. . La reproduction et la diffusion, même partielle, sous quelque forme, et/ou l'utilisation sans autorisation sont interdits. La société peut, dans le perfectionnement des produits, en modifier les caractéristiques techniques et esthétiques. Les modèles peuvent être différents selon les pays.

DE Copyright © 2018. Alle Rechte an den Katalog, auf Bilder und Texte, Marken und Kennzeichen sind vertraulich und von Gruppo Piazzetta s.p.a. unternehmensintern reserviert. Die Vervielfältigung und Verbreitung, auch nur teilweise, in irgendeiner Form und/oder unberechtigte Verwendung sind unzulässig. Das Unternehmen hat die Möglichkeit bei Produktverbesserungen technische und ästhetische Eigenschaften zu ändern. Die Modelle können von Land zu Land unterschiedlich sein.

ES Copyright © 2018. Todos los derechos sobre el catálogo, imágenes y textos, marcas comerciales y logotipos son propiedad del Gruppo Piazzetta s.p.a. . Queda prohibida la reproducción y la difusión, incluso parcial, de cualquier forma, y / o uso no autorizado. La empresa puede, en el perfeccionamiento de los productos, modificar las características técnicas y estéticas sin previo aviso. Los modelos pueden variar de un país a otro.

# Idee intorno al fuoco

Realizzare soluzioni innovative di riscaldamento, unire qualità ed estetica, sviluppando intorno al fuoco nuove idee ed atmosfere per farne il vero centro della casa: questo è l'impegno di Piazzetta.



## **EN** Ideas around the fire

Create innovative heating solutions, merging quality and aesthetics, develop new ideas and atmospheres around fire to make it the fulcrum of the home: these are the objectives that Piazzetta pursues.

## **FR** Des idées autour du feu

Réaliser des solutions innovantes, allier la qualité à l'esthétique, développer de nouvelles idées autour du feu et créer la juste atmosphère pour le mettre au cœur de la maison : c'est là l'engagement de Piazzetta.

## **DE** Ideen rund ums Feuer

Innovative Heizlösungen realisieren, Qualität und Ästhetik miteinander verbinden, neue Ideen und Atmosphären rund ums Feuer entwickeln, um es zum Mittelpunkt des eigenen Heims werden zu lassen: Dafür steht Piazzetta.

## **ES** Ideas alrededor del fuego

Realizar soluciones innovadoras de calefacción, unir la calidad a la estética, desarrollando alrededor del fuego nuevas ideas y atmósferas para convertirlas en el verdadero centro de la casa: es el compromiso de Piazzetta.

# Piazzetta Total Comfort

---

Scegli tra la più ampia gamma di caminetti e stufe a legna, pellet, gas. Stile, design, tecnologia, qualità dei prodotti e la ricercatezza dei particolari tutta italiana. Un mondo di certezze sul quale contare, anche grazie alla professionalità dei centri di assistenza tecnica Piazzetta sul territorio. Professionisti a tua disposizione formati dall'Azienda, sempre aggiornati e disponibili.

**EN** Choose among the widest range of wood, pellet and gas burning stoves and fireplaces. Distinctly Italian in style, design, technology product quality and refined details. A world of certainties which you can rely on thanks to the expertise available through Piazzetta trained service centres. Up-to-date professionals willing to assist you.

**FR** Choisissez parmi la plus riche gamme de cheminées et poêles à bois, pellet ou gaz. Style, design, technologie, qualité des produits et raffinement des détails typiquement italien. Un monde de certitudes sur lequel compter, grâce au professionnalisme des Service après vente Piazzetta, formés par notre entreprise et toujours disponibles.



**DE** Wählen Sie aus dem größten Angebot an Kaminen und Öfen mit Holz-, Pellet- oder Gasfeuerung das für Sie passende Modell aus. Stil, Design, Technologie, Produktqualität und raffinierte Detailauswahl auf Italienisch. Eine Welt sicherer Werte, auf die Sie zählen können. Auch dank des regionalen, professionellen Techn. Kundendienstes mit von Piazzetta aus- und weitergebildeten Fachkräften.

**ES** Elige entre la más amplia gama de chimeneas y estufas de leña, pellets, gas. Estilo, diseño, tecnología, calidad de producto, detalles refinados puramente italianos. Un mundo de certezas con las que contar, incluso por la profesionalidad de los centros de asistencia técnica Piazzetta. Profesionales a tu disposición, siempre informados, capacitados por la empresa.

# Passione Accesa da oltre 50 anni

---

La nostra è una passione artigiana tutta italiana, dove estetica e tecnologia si uniscono per creare elementi di arredo protagonisti del vivere moderno. Da sempre ricerchiamo e progettiamo in Italia, ad Asolo, soluzioni esclusive, offriamo in ogni nostro prodotto i massimi standard di efficienza, praticità, sicurezza, con un design ed una qualità dei materiali e delle lavorazioni che ci contraddistinguono.



**EN A burning passion for over 50 years.**

Genuine Italian artisan passion merging aesthetics and technology to create furnishing elements that exemplify modern day living. Our Italian cultural roots have always been based in Asolo where we set our goals to achieve the highest standards in efficiency, practicality and the utmost in safety in each of our products which reflect our unique characteristic of design and quality.

**FR Passion enflammée depuis plus de 50 ans**

Notre passion est une passion artisanale 100% italienne où esthétique et technologie donnent vie à des éléments véritables acteurs de la vie contemporaine. C'est en Italie, à Asolo que nous recherchons et concevons depuis toujours des solutions exclusives. Nous offrons à travers chacun de nos produits les plus hauts standards de rendement, confort d'utilisation et sécurité, avec un design et une qualité des matériaux et des réalisations qui nous caractérisent.

**DE Brennendes Feuer seit über 50 Jahren.**

Unser Handwerk leben wir mit italienischer Leidenschaft und als gelungene Verknüpfung von Ästhetik und Technologie zur Herstellung von Einrichtungsgegenständen, die zu Protagonisten modernen Wohnens geworden sind. Seit der Gründung unserer Firma forschen und entwickeln wir im norditalienischen Asolo, um exklusive Lösungen, hohe Benutzerfreundlichkeit, Sicherheit, erlesenes Design und beste Qualität zu liefern.

**ES Pasión encendida desde hace más de 50 años**

La nuestra es una pasión artesanal totalmente italiana, donde la estética y la tecnología se unen para crear elementos de decoración protagonistas del vivir moderno. En Asolo, Italia, concebimos y diseñamos soluciones exclusivas, ofrecemos en cada producto los máximos estándares de eficiencia, practicidad, seguridad, con un diseño y una calidad de material y elaboración que nos distingue.



# Prodotti fatti per durare nel tempo

La solidità dei nostri prodotti è fatta di tanta esperienza e continua ricerca. Dalla selezione delle materie prime alle singole fasi di lavorazione, tutto viene controllato nei minimi dettagli da personale specializzato. Nei nostri laboratori si sviluppa il prodotto e viene testata la produzione e la rispondenza alle normative internazionali. Le stufe Piazzetta mantengono le loro caratteristiche nel tempo, per questo offriamo una estensione gratuita della garanzia per 5 anni.

## **EN** Products that endure time.

The sturdiness of our products stems from extensive experience and on-going research. Starting from the selection of raw materials to every single processing phase, everything is checked right down to the slightest detail by our specialized personnel. In our laboratories the products are tested for their conformity to international regulations. Piazzetta stoves retain their characteristic over time: this is why we offer a free - 5 year warranty extension.

## **FR** Des produits faits pour durer dans le temps

Nos produits doivent leur solidité à notre bagage d'expérience et à notre travail de recherche continue. Du choix des matières premières aux nombreuses phases de réalisation, tout est contrôlé dans le moindre détail par notre personnel spécialisé. Nos ateliers développent le produit et font des essais sur la production et sur sa conformité aux normes internationales. Les poêles Piazzetta conservent leurs caractéristiques au long des années, c'est d'ailleurs pour cette raison que nous offrons une extension de garantie de 5 ans.

## **DE** Produkte, die Jahrzehnte überdauern.

Die solide Struktur unserer Produkte basiert auf langjähriger Erfahrung und kontinuierlicher Forschung. Von der Auswahl der Rohstoffe bis zu den einzelnen Bearbeitungsphasen wird alles bis ins kleinste Detail von spezialisierten Fachkräften kontrolliert. Unsere Labors entwickeln das Produkt, testen die Produktion und prüfen das Resultat mit den Vorgaben internationaler Normen. Die Öfen von Piazzetta behalten ihre Wertigkeit über lange Zeit, weshalb wir bei der Brennkammer eine kostenlose Erweiterung der Garantie auf über 5 Jahre gewährleisten können.

## **ES** Productos hechos para durar a lo largo del tiempo

La solidez de nuestros productos está hecha de mucha experiencia y de continuos estudios. Desde la selección de las materias primas hasta las fases de elaboración, todo es detalladamente controlado por personal especializado. En nuestros talleres se desarrolla el producto, se verifica la producción y se comprueba la conformidad con las normas internacionales. Las estufas Piazzetta mantienen sus características a lo largo del tiempo. Por eso ofrecemos gratuitamente una extensión de 5 años de la garantía.

EASY LIFE  
PIAZZETTA

GARANZIA  
WARRANTY

5

ANNI-YEARS

RICAMBI  
PARTS

10

ANNI-YEARS

[easylife.piazzetta.it](http://easylife.piazzetta.it)

## Certificazioni

**EN** Certifications  
**FR** Certifications  
**DE** Zertifizierungen  
**ES** Certificaciones







# Maiolica artigianale

L'arte della lavorazione artigianale della Maiolica ci consente di realizzare oggetti unici. La tecnologia delle migliori stufe a pellet incontra una materia che ancora si plasma a mano: la Maiolica. Solo pezzi unici che, colati negli stampi, asciugati lentamente e verniciati a mano, richiedono 15 giorni di tempo per la lavorazione.

Rivestimenti in Maiolica in oltre 40 colori e differenti finiture vengono realizzati in azienda, nella più grande fabbrica europea di produzione di Maiolica del settore.

## **EN** Handcrafted Majolica

The art of Majolica handcrafting allows us to create unique objects. The best pellet stove technology encounters a material that is still conjured manually: Majolica. Only single pieces are produced; after being cast in moulds, dried slowly and coated by hand, they require 15 days of crafting. Majolica surrounds in over 40 colours and different finishes are made within the company, in Europe's largest Majolica production factory in the sector.

## **FR** Faïence artisanale

L'art du façonnage artisanal de la Faïence nous permet de réaliser des objets uniques. La technologie des poêles à pellet rencontre une matière que l'on modèle encore à la main : la Faïence. Des pièces uniques moulées, séchées lentement et peintes à la main qui exigent 15 jours de travail pour leur réalisation. Des revêtements en Faïence dans plus de 40 coloris et dans de nombreuses finitions sont réalisés sur place, dans la plus grande usine européenne du secteur produisant de la Faïence.





#### **DE Handwerkliche Fertigung**

Die Kunst der handwerklichen Bearbeitung von Majolika ermöglicht es, einzigartige Produkte zu kreieren. Neueste Technologie in Pelletöfen trifft auf ein Material, das noch von Hand geformt wird: Majolika. Es entstehen in einem 15-tägigen Prozess einzigartige Stücke, die in Formen gegossen, langsam getrocknet und manuell glasiert werden. Majolika-Verkleidungen in über 40 Farben und Finishes in der größten europ. Majolika-Manufaktur in unserem Bereich.

#### **ES Mayólica artesanal**

El arte de la elaboración artesanal de la Mayólica nos permite realizar objetos únicos. La tecnología de las mejores estufas de pellets emplea una materia que se plasma a mano: la mayólica. Sólo piezas únicas que, coladas en los moldes, secadas lentamente y pintadas a mano, requieren 15 días para la elaboración. Revestimientos de Mayólica en más de 40 colores y distintos acabados se realizan en la empresa, en la mayor fábrica europea de producción de Mayólica del sector.

# Rivestimenti: i Veneziani

---

La collezione *I Veneziani* racchiude gli esclusivi rivestimenti Piazzetta realizzati in pregiata Maiolica o in Argilla, lavorati a mano con sapiente cura artigianale. Il calore e la suggestiva atmosfera che la fiamma crea in ogni ambiente rendono unico il comfort dell'abitare. Soluzioni funzionali ed efficienti, espressioni uniche di design.

**EN** The *I Veneziani* collection includes the exclusive Piazzetta surrounds made of fine majolica or clay, hand-worked through skilled craftsmanship. The warmth and charming atmosphere radiated by the flame in every room ensure a unique living comfort. Practical and efficient solutions revealing a unique design.

**FR** La collection *I Veneziani* regroupe les revêtements exclusifs Piazzetta réalisés en faïence ou en terre, savamment façonnés à la main avec un soin artisanal. La chaleur et l'atmosphère évocatrice que crée la flamme dans n'importe quel espace sont à l'origine d'un confort unique. Des solutions fonctionnelles et performantes, expressions d'un design unique.

Surrounds: i Veneziani  
Revêtements : i Veneziani  
Verkleidungen: i Veneziani  
Revestimientos: i Veneziani

**DE** Die Kollektion *i Veneziani* umfasst die exklusiven Piazzetta Verkleidungen aus edler Majolika oder Ton, die mit handwerklicher Sorgfalt gefertigt werden. Die Wärme und stimmungsvolle Atmosphäre, welche die Flamme im Raum schafft, machen den Wohnkomfort einmalig. Funktionale, effiziente Lösungen, einzigartiger Ausdruck von Design.

**ES** La colección *i Veneziani* reúne los exclusivos revestimientos Piazzetta realizados en preciada mayólica o en arcilla, trabajados a mano con sabio esmero artesanal. El calor y la sugestiva atmósfera que crea la llama en cualquier ambiente, dan un toque de exclusividad al confort de la vivienda. Soluciones funcionales y eficientes, expresiones de diseño únicas.

# Linea Basic

**L'arte della lavorazione artigianale della Maiolica consente di realizzare oggetti unici, per dimensioni, qualità e bellezza rendendo ogni caminetto un'opera esclusiva.**

**I rivestimenti in Maiolica della linea Basic, in oltre 40 colori e differenti finiture garantiscono soluzioni innovative ed esclusive per la realizzazione del tuo caminetto.**

**Il fascino della superficie in Maiolica esalta ulteriormente il fuoco che racchiude, e l'ampia gamma di focolari tra cui scegliere garantisce soluzioni di stile e design.**

## **EN Basic range**

The artisan crafting of majolica yields objects unique objects in terms of size, quality and beauty, making each fireplace an exclusive work. The majolica surrounds of the Basic range, available in over 40 colours and various finishes, guarantee innovative and exclusive solutions to create your fireplace. The allure of the majolica surfaces further enhances the fire they enclose, while the extensive assortment of fireboxes includes stylish, design-oriented solutions.

## **FR Ligne Basic**

L'art du façonnage artisanal de la faïence permet la réalisation d'objets uniques en termes de dimensions, de qualité et de beauté, faisant de chaque cheminée une œuvre exclusive. Les revêtements en faïence de la ligne Basic, disponibles dans plus de 40 couleurs et différentes finitions, garantissent des solutions innovantes et exclusives pour votre cheminée. Grâce au charme de la faïence, le feu se trouve exalté et la large gamme de foyers disponibles est synonyme de solutions stylées et design.

## **DE Basic-Linie**

Die Kunst der handwerklichen Bearbeitung von Majolika ermöglicht es, in Abmessungen, Qualität und Schönheit einzigartige Produkte zu realisieren, die jeden Kamin zu einem exklusiven Werk machen. Die Majolika-Verkleidungen der Basic-Linie in über 40 Farben und verschiedenen Finishes sorgen für innovative, exklusive Lösungen zur Realisierung Ihres Kamins. Die Majolika-Oberfläche unterstreicht den Charme des Feuers, das sie umschließt. Die große Auswahl an Feuerräumen garantiert Lösungen mit Stil und Design.

## **ES Línea Basic**

El arte de la elaboración artesana de la mayólica permite obtener objetos únicos en términos de dimensiones, calidad y belleza, para hacer de cada chimenea una obra exclusiva. Los revestimientos de mayólica de la línea Basic, en más de 40 colores y acabados, garantizan soluciones innovadoras y distintivas para la realización de la chimenea. El encanto de la superficie de mayólica aviva aún más el fuego que contiene, y la amplia propuesta de hogares ofrece resultados únicos en cuanto a estilo y diseño.



# Linee Elegance e Luxury

**Ricerca, tecnologia, design, arte danno origine a questa collezione di caminetti che emergono e si fanno riconoscere per la loro affascinante bellezza. Solo una attenta ricerca stilistica, e la cura delle molte lavorazioni manuali fanno nascere i rivestimenti delle linee Elegance e Luxury. Solo l'amore per la Maiolica consente a maestri artigiani di dar vita ad opere uniche, ciascuna destinata a personalizzare e dare carattere all'ambiente in cui verrà inserita, esprimendo la personalità di chi le sceglie.**

## **EN Elegance and Luxury ranges**

Research, technology, design and art define this collection of fireplaces distinguished by their fascinating beauty. The surrounds of the Elegance and Luxury ranges stem from attentive research on style and a series of carefully hand-worked details. Fuelled by their passion for majolica, the master craftsmen create unique works that personalise their setting and imbue it with character, revealing the personality of the customers.

## **DE Linien Elegance und Luxury**

Forschung, Technologie, Design und Kunst stehen am Ursprung dieser Kamin-Kollektion, die sich durch ihre bezaubernde Schönheit auszeichnen. Die Verkleidungen der Linien Elegance und Luxury entstehen nur durch akkurate Stilsuche und Sorgfalt bei den zahlreichen Bearbeitungen von Hand. Nur durch die Liebe zur Majolika können Handwerksmeister einzigartige Werke schaffen, die den Räumen, in die sie eingefügt werden, individuellen Charakter verleihen und die Persönlichkeit des Bewohners ausdrücken.

## **FR Lignes Elegance et Luxury**

Recherche, technologie, design et art sont à l'origine de cette collection de cheminées qui sortent du lot grâce à leur beauté fascinante. Seuls la recherche stylistique poussée et le soin apporté aux nombreux façonnages manuels ont pu donner naissance aux revêtements des lignes Elegance et Luxury. C'est grâce à leur amour de la faïence que les maîtres artisans ont pu créer ces œuvres uniques, qui personnalisent et donnent du caractère aux lieux, en exprimant la personnalité de ceux qui les ont choisis.

## **ES Líneas Elegance y Luxury**

La investigación, la tecnología, el diseño y el arte dan origen a esta colección de chimeneas que afloran y se dejan reconocer por su encanto. Solo la refinada búsqueda de la perfección estilística y el esmero en la confección manual pueden dar vida a los revestimientos de las líneas Elegance y Luxury. Solo el amor por la mayólica permite a los maestros artesanos concebir obras únicas, destinadas a definir y caracterizar el espacio en el que se ubicarán, reflejando la personalidad de quien las elige.





# Le Terre

**I migliori impasti di argilla, plasmati sapientemente a mano, decorati uno ad uno con grande esperienza e passione danno vita ad opere esclusive. Ogni dettaglio è il risultato di ricerca sui materiali e processi che racchiudono l'esperienza dei maestri dell'argilla. Ogni cornice diventa un pezzo unico e inimitabile. Solo in Piazzetta la scuola dell'esperienza tramandata di giorno in giorno in oltre 50 anni di storia consente di concepire e dar vita ad opere uniche nel mondo. Tecnologia, design, arte, pezzi firmati uno ad uno.**

## **EN Clay**

The best clay pastes ably moulded by hand, decorated individually with expertise and passion to yield exclusive works. Each detail stems from research on materials and processes forged by the experience of clay master craftsmen. Each frame turns into a single piece that defies imitation. Only at Piazzetta the experience handed down daily in over 50 years allows for conceiving and creating works that are unique in the world. Individually signed pieces brimming with technology, design and art.

## **DE Die Erden**

Aus besten Tonmassen, die sorgfältig von Hand geformt und Stück für Stück mit großer Erfahrung und Leidenschaft dekoriert werden, entstehen exklusive Arbeiten. Jedes Detail ist Ergebnis von Forschung an Materialien und Prozessen, in welche die Erfahrung der Meister der Tonbearbeitung einfließt. Jeder Rahmen wird zum einmaligen Einzelstück. Nur bei Piazzetta können durch die Schule der in über 50 Jahren überlieferten Erfahrung in der Welt einmalige Werke konzipiert werden. Technik, Design, Kunst, jedes einzelne Stück signiert.

## **FR Les Terres**

Seules les meilleures terres, savamment modelées à la main et décorées une par une avec expérience et passion, peuvent donner naissance à des œuvres exclusives. Chaque détail résulte de recherches sur les matériaux et de procédures qui renferment l'expérience des maîtres potiers. Chaque cadre est ainsi unique et inimitable. Chez Piazzetta, l'expérience est transmise de jour en jour depuis plus de 50 ans, ce qui permet de concevoir et de fabriquer des pièces uniques au monde. Technologie, design et art : des pièces à la signature unique.

## **ES Las Tierras**

Las mejores mezclas de arcilla, plasmadas sabiamente a mano, decoradas una a una con gran experiencia y pasión, dan vida a obras exclusivas. Cada detalle es fruto de una atenta búsqueda de materiales y procesos que abarcan la experiencia de los maestros de la arcilla. Cada marco se convierte en una pieza única e inimitable. Solo en Piazzetta la escuela de la experiencia transmitida día a día en más de 50 años de historia permite concebir y dar a luz obras únicas en el mundo. Tecnología, diseño, arte, piezas marcadas una por una.



# Maiolica in oltre 40 tonalità, anche su richiesta

La lavorazione artigianale della Maiolica, effettuata nel nostro stabilimento interno, ci consente di offrire la più ampia scelta di colori per i rivestimenti dei nostri caminetti. Ogni prodotto viene proposto nei suoi colori di serie, ma può essere richiesto anche nel colore che preferisci. Perché la nostra produzione è fatta di soli "pezzi unici". L'esperienza della lavorazione e la cura per i particolari ci contraddistinguono, l'originalità ci fa riconoscere.

## **EN** Majolica offered in over 40 shades, even on request.

The artisan processing of the Majolica, realized in-house at our plant, enables us to offer a broad assortment of colours for our fireplace claddings. Each product is proposed in its standard colours, but can be requested in preferential colours, because our production is made up of "single pieces". Processing expertise and finely worked details distinguish our products, making them unique.

## **FR** Faïence disponible dans plus de 40 teintes, sur demande aussi.

Le façonnage artisanal de la Faïence, effectué dans notre usine, nous permet d'offrir un très vaste choix de couleurs pour les habillages de nos cheminées. Chaque produit est proposé dans ses coloris de série, mais il peut également être commandé dans le coloris que vous préférez. Car notre production compte uniquement des « pièces uniques ». Le savoir-faire et le soin des détails nous caractérisent, l'originalité fait qu'on nous reconnaît.

## **DE** Majolika in über 40 Farben, auch auf Anfrage.

Die handwerkliche Bearbeitung der Majolika erfolgt in unserer hauseigenen Manufaktur, wodurch wir ein umfassendes Farbspektrum für die Verkleidung unserer Kamine anbieten können. Jedes Produkt ist in den vorgesehenen serienmäßigen Farben erhältlich, kann aber auch als Sonderglasur bestellt werden, da unsere Produktion ausschließlich handgemachte Majolika fertigt. Erfahrung in der Bearbeitung, sorgfältige Auswahl der Komponenten und Originalität sind unsere Erkennungszeichen.

## **ES** Mayólica en más de 40 colores, incluso bajo petición.

La elaboración artesanal de la Mayólica, efectuada internamente en fábrica, permite ofrecer la más amplia gama de colores para los revestimientos de nuestras chimeneas. Cada producto se propone en sus colores de serie, pero también se pueden pedir colores especiales. Porque nuestra producción se compone de "piezas únicas". Nos distinguen la experiencia de la elaboración, el cuidado de los detalles y la originalidad.

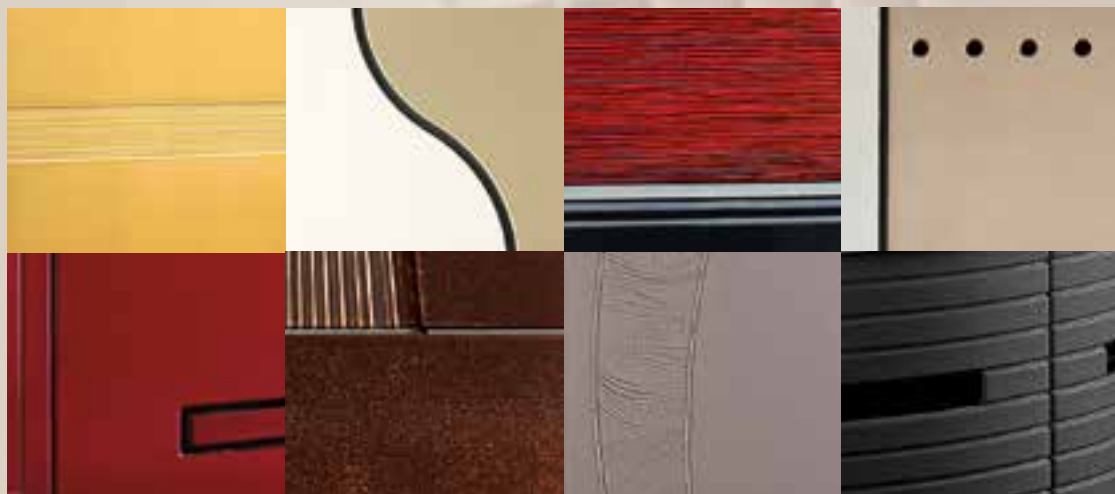



Bianco



Bianco Antico



Bianco Grigio



Ardesia



Sahara



Kaki



Tortora



Terra Cotta



Senape



Mattone



Marrone Tenné



Nero Opaco



Giallo Acceso



Rosso Lava



Tabacco



Bruno Rame



Grigio Cerato



Grigio Ferro



Moka



Nero Grafite



Ollare



Neve



Blu Verdemare

# Linee Elegance e Luxury dalla preziosa lavorazione

La lavorazione artigianale della Maiolica, effettuata nel nostro stabilimento interno, ci consente di offrire la più ampia scelta di colori per i rivestimenti dei nostri caminetti. Ogni prodotto viene proposto nei suoi colori di serie, ma può essere richiesto anche nel colore che preferisci. Perché la nostra produzione è fatta di soli "pezzi unici". L'esperienza della lavorazione e la cura per i particolari ci contraddistinguono, l'originalità ci fa riconoscere.

**EN Majolica offered in over 40 shades, even on request.**

The artisan processing of the Majolica, realized in-house at our plant, enables us to offer a broad assortment of colours for our fireplace claddings. Each product is proposed in its standard colours, but can be requested in preferential colours, because our production is made up of "single pieces".

Processing expertise and finely worked details distinguish our products, making them unique.

**FR Faïence disponible dans plus de 40 teintes, sur demande aussi.**

Le façonnage artisanal de la Faïence, effectué dans notre usine, nous permet d'offrir un très vaste choix de couleurs pour les habillages de nos cheminées. Chaque produit est proposé dans ses coloris de série, mais il peut également être commandé dans le coloris que vous préférez. Car notre production compte uniquement des « pièces uniques ». Le savoir-faire et le soin des détails nous caractérisent, l'originalité fait qu'on nous reconnaît.

**DE Majolika in über 40 Farben, auch auf Anfrage.**

Die handwerkliche Bearbeitung der Majolika erfolgt in unserer hauseigenen Manufaktur, wodurch wir ein umfassendes Farbspektrum für die Verkleidung unserer Kamine anbieten können. Jedes Produkt ist in den vorgesehenen serienmäßigen Farben erhältlich, kann aber auch als Sonderglasur bestellt werden, da unsere Produktion ausschließlich handgemachte Majolika fertigt. Erfahrung in der Bearbeitung, sorgfältige Auswahl der Komponenten und Originalität sind unsere Erkennungszeichen.

**ES Mayólica en más de 40 colores, incluso bajo petición.**

La elaboración artesanal de la Mayólica, efectuada internamente en fábrica, permite ofrecer la más amplia gama de colores para los revestimientos de nuestras chimeneas. Cada producto se propone en sus colores de serie, pero también se pueden pedir colores especiales. Porque nuestra producción se compone de "piezas únicas". Nos distinguen la experiencia de la elaboración, el cuidado de los detalles y la originalidad.



---

**LINEA ELEGANCE**



Bianco  
Calce



Bianco  
Setolato



Nero  
Ingobbio



Moka  
Pennellato



Grigio Bruno



Verde  
Pennellato



Tortora

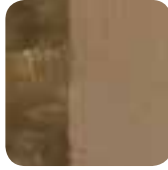

Tabacco



Grigio  
Metal



Orange  
Pennellato



Corallo



Grigio Rosso



Viola Alba



Prugna

---

**LINEA LUXURY**



Platino



Platino  
Decorato



Platino  
Damascato



Oro



Oro  
Decorato



Oro  
Damascato



Rame



Rame  
Decorato



Rame  
Damascato





# HOBART

**Una nuova proposta di design, stile, innovazione, versatilità. Per arredare in modo originale una parete, un ingresso, un grande salone. Lo spettacolo del fuoco trova una nuova convincente soluzione per entrare e portare calore nelle case di chi ama concedersi il suo piacere. Una ampia gamma di focolari e rivestimenti possibili arricchisce questo progetto.**

**EN** A fresh concept in design, style, innovation, and flexibility, to furnish a wall, a hall, or a large room in a unique way. This new outstanding solution brings the spectacular view and warmth of fire into the homes of those who love its exclusive comfort. This collection offers an extensive range of fireplaces and a rich selection of surround options.

**DE** Ein neuer Design, Stil, Innovation und Vielseitigkeitsvorschlag. Um eine Mauer, einen Eingang, eine große Halle originell einzurichten. Das Feuererlebnis findet eine neue überzeugende Lösung, um Wärme in die Häuser derer zu bringen, die ihrem Vergnügen nachgehen möchten. Eine breite Palette von Kaminen und Verkleidungen bereichert dieses Projekt.

**FR** Une nouvelle proposition pour le design, le style, l'innovation, la polyvalence. Fournir de manière originale un mur, une entrée, une grande salle. Le spectacle de feu trouve une nouvelle solution convaincante pour entrer et apporter de la chaleur dans les maisons de ceux qui aiment se faire plaisir. Une large gamme de cheminées et de revêtements peut enrichir ce projet.

**ES** Una nueva propuesta de diseño, estilo, innovación y versatilidad. Para decorar de manera original una pared, una entrada, o un gran salón. El espectáculo del fuego encuentra una nueva solución convincente para traer calor en las habitaciones de las personas que aman el calor. Una amplia gama de hogares y revestimientos posibles enriquece el proyecto.



## COLORI - COLOURS

Ardesia	Senape
Bianco	Tabacco
Bianco Antico	Terra Cotta
Bianco Grigio	Tortora
Kaki	Nero Grafite
Mattone	Marrone Tenné
Sahara	



→ Colori - Colours P.19

→ Focolari compatibili - Compatible fireboxes P.242



# LUGANO

**L'originale Stufa-Caminetto dall'innovativo stile moderno. È possibile scegliere anche focolari a sviluppo orizzontale per godere al massimo del piacere della visione del fuoco. Rivestito in Maiolica con pannelli di grandi dimensioni nei colori Bianco, Nero Opaco, Rosso Lava o Terra Cotta. Disponibile anche in versione con sistema BCS.**

**EN** This original stove-fireplace has an innovative modern style. It can be selected with a horizontal firebox to get the best view of the flame. Fitted with large-format Majolica panels in Bianco, Nero Opaco, Rosso Lava and Terra Cotta. Also available with BCS.

**DE** Origineller Kaminofen mit innovativem, modernem Stil. Sie können sich für einen Heizeinsatz mit horizontaler Ausrichtung entscheiden, um das Feuer noch besser genießen zu können. Mit großformatigen Majolika-Kacheln in den Farben Bianco, Nero Opaco, Rosso Lava o Terra Cotta verkleidet. Auch als Version mit BCS-System erhältlich.

**FR** L'original poêle-cheminée au style moderne innovant. Il est également possible de choisir des foyers à développement horizontal pour profiter au maximum du plaisir de la vision du feu. Habillage en faïence avec grands panneaux dans les coloris Bianco, Nero Opaco, Rosso Lava ou Terra Cotta. Disponible également en version BCS.

**ES** La original estufa-chimenea con un estilo moderno innovador. Se pueden elegir también hogares con disposición horizontal para disfrutar plenamente del placer de la visión del fuego. Revestimiento de mayólica con paneles de dimensiones grandes en Bianco, Nero Opaco, Rosso Lava o Terra Cotta. Disponible también en versión con sistema BCS.



#### COLORI - COLOURS

Bianco  
Terra Cotta  
Rosso Lava  
Nero Opaco



PELLET



WOOD



AIR

→ Colori - Colours P.19

→ Focolari compatibili - Compatible fireboxes P.242



# BERNA

**Un nuovo stile moderno caratterizza questa originale Stufa-Caminetto, che personalizza l'ambiente in cui viene installata. Rivestimento in Maiolica con pannelli di grandi dimensioni nei colori Bianco, Nero Opaco, Rosso Lava o Terra Cotta. Possono essere scelti focolari in differenti potenze e misure. Disponibile anche in versione BCS.**

**EN** This new modern stove-fireplace adds style to any interior. Covered with large-format Majolica panels in Bianco, Nero Opaco, Rosso Lava and Terra Cotta. It can be selected with fireboxes with different capacities, proportions and sizes. Also available with BCS.

**DE** Der originelle Kaminofen in modernem Stil, der Ihrer Wohnung eine individuelle Note verleiht. Verkleidung aus großformatigen Majolika-Kacheln in den Farben Bianco, Nero Opaco, Rosso Lava oder Terra Cotta. Die Heizeinsätze sind in unterschiedlichen Leistungsstärken, Proportionen und Maßen wählbar. Auch als BCS-Version erhältlich.

**FR** Cet original poêle-cheminée se distingue par un nouveau style moderne qui personnalise la pièce où il est installé. Habillage en faïence avec grands panneaux dans les coloris Bianco, Nero Opaco, Rosso Lava ou Terra Cotta. Possibilité de choisir des foyers de différentes puissances et dimensions. Disponible également en version BCS.

**ES** Un nuevo estilo moderno caracteriza esta original estufa-chimenea, que personaliza el ambiente en el cual se instala. Revestimiento de mayólica con paneles de dimensiones grandes en Bianco, Nero Opaco, Rosso Lava o Terra Cotta. Pueden elegirse hogares de distintas potencias, proporciones y medidas. Disponible también en versión BCS.



#### COLORI - COLOURS

Bianco  
Terra Cotta  
Rosso Lava  
Nero Opaco



→ Colori - Colours P.19

→ Focolari compatibili - Compatible fireboxes P.240



# DAVOS

**L'originale Stufa-Caminetto dalle forme compatte e un nuovo stile moderno che caratterizza l'ambiente in cui viene installato. Rivestimento in Maiolica con pannelli di grandi dimensioni nei colori Bianco, Nero Opaco, Rosso Lava o Terra Cotta. Possono essere scelti focolari in differenti potenze, proporzioni e misure. Disponibile anche in versione BCS.**

**EN** This original stove-fireplace with a compact shape and new modern styling adds style to any interior. Covered with large-format Majolica panels in Bianco, Nero Opaco, Rosso Lava and Terra Cotta. It can be selected with fireboxes with different capacities, proportions and sizes. Also available with BCS.

**DE** Der originelle Kaminofen mit kompakten Formen und modernem Stil. Verkleidung aus großformatigen Majolika-Kacheln in den Farben Bianco, Nero Opaco, Rosso Lava oder Terra Cotta. Die Heizeinsätze sind in unterschiedlichen Leistungsstärken, Proportionen und Maßen wählbar. Auch als BCS-Version erhältlich.

**FR** L'original poêle-cheminée aux formes compactes et au nouveau style moderne qui distingue la pièce où il est installé. Habillage en faïence avec grands panneaux dans les coloris Bianco, Nero Opaco, Rosso Lava ou Terra Cotta. Possibilité de choisir des foyers de différentes puissances, proportions et dimensions. Disponible également en version BCS.

**ES** La original estufa-chimenea de formas compactas y un nuevo estilo moderno. Revestimiento de mayólica con paneles de dimensiones grandes en Bianco, Nero Opaco, Rosso Lava o Terra Cotta. Pueden elegirse hogares de distintas potencias, proporciones y medidas. Disponible también en versión BCS.



#### COLORI - COLOURS

Bianco  
Terra Cotta  
Rosso Lava  
Nero Opaco



→ Colori - Colours P.19

→ Focolari compatibili - Compatible fireboxes P.241







# NEWPORT

**Caminetto per installazione a filomuro che non necessita di opere murarie per la posa. Due grandi elementi in Maiolica lavorata a mano racchiudono il focolare a legna. Il rialzo diviene il portalegna ideale, le mensole laterali realizzate anch'esse in acciaio verniciato nero lo rendono un prezioso elemento d'arredo.**

**EN** A flush-fitted fireplace that does not require any masonry works for its installation. Two large hand-crafted majolica elements envelop the wood-burning firebox. The riser functions as an ideal log holder, while the side shelves – also made of black-coated steel – turn the product into a refined furnishing element.

**DE** Kamin für Installation an der Wand, dessen Einbau keine Maurerarbeiten erfordert. Zwei große Elemente aus handgearbeiteter Majolika umschließen den Feuerraum für Holzfeuerung. Der Aufsatz ist ideal zum Lagern des Brennholzes, die seitlichen Konsolen, ebenfalls aus schwarz lackiertem Stahl, machen den Kamin zum wertvollen Einrichtungselement.

**FR** Cheminée à installer au ras du mur, ne nécessitant pas de travaux de maçonnerie. Le foyer à bois est entouré de deux grands éléments en faïence façonnée à la main. La rehausse constitue un compartiment idéal pour ranger le bois, tandis que les étagères latérales réalisées elle aussi en acier peint noir font de ce modèle un élément décoratif précieux.

**ES** Chimenea para instalación a ras del muro sin obras de albañilería para la colocación. Dos grandes elementos de mayólica trabajada a mano contienen el hogar de leña. El realce se convierte en el portaleña ideal; las repisas laterales, también estas en acero pintado, hacen de ella un precioso elemento de decoración.



#### COLORI - COLOURS

Ardesia	Senape
Bianco	Tabacco
Bianco Antico	Terra Cotta
Bianco Grigio	Tortora
Kaki	
Mattone	
Sahara	



→ Colori - Colours P.19

→ Focolari compatibili - Compatible fireboxes P.242



# EDINBURGH

**Particolare rivestimento in Maiolica lavorata a mano. La base è ricavata da un unico elemento in Maiolica di pregevole manifattura, il rialzo è in marmo, tinteggiabile a piacere. La Maiolica è disponibile in una svariata gamma di colori. Particolare il focolare a tre vetri per una perfetta visione della fiamma.**

**EN** Highly original hand-crafted majolica surround. The base is derived from a single, finely crafted majolica element, while the riser is made of marble and can be coated as desired. The majolica comes in a variety of colours. A distinctive feature is the three-sided glass, ensuring a perfect view of the flame.

**DE** Besondere Verkleidung aus handgearbeiteter Majolika. Der Sockel besteht aus einem einzigen Element aus hochwertiger Majolika, der Aufsatz ist aus Marmor, der nach Belieben eingefärbt werden kann. Die Majolika ist in einer breiten Farbpalette erhältlich. Der an drei Seiten verglaste Feuerraum bietet eine perfekte Sicht auf das Feuer.

**FR** Revêtement particulier en faïence façonnée à la main. Base fabriquée d'un seul tenant en faïence de très belle facture et rehausse à teinter au gré de ses envies. La faïence est disponible dans une vaste gamme de couleurs variées. Le foyer particulier dispose de trois vitres assurant une vision parfaite de la flamme.

**ES** Revestimiento particular de mayólica trabajada a mano. La base se obtiene a partir de un único elemento de mayólica de preciaada manufactura; realce de mármol que puede pintarse al gusto. La mayólica está disponible en una amplia gama de colores. Singular hogar de tres vidrios para una perfecta visión de la llama.



## COLORI - COLOURS

Ardesia	Tabacco
Bianco Antico	Terra Cotta
Bianco Grigio	Tortora
Kaki	
Mattone	
Sahara	
Senape	



→ Colori - Colours P.19

→ Focolari compatibili - Compatible fireboxes P.241





# KENSINGTON

**Rivestimento con base in Maiolica lavorata a mano, priva di qualsiasi punto di giunzione ricavata da un unico elemento grazie ad una ricercata esecuzione. Disponibile in un'ampia gamma di colori. Rialzo in marmo tinteggiabile a piacere. Focolare a tre vetri per una perfetta visione della fiamma.**

**EN** Surround with hand-crafted majolica base, without any joints, derived from a single element, thanks to skilled workmanship. Available in an extensive range of colours. Coatable marble riser. Firebox with three-panel glass for a perfect view of the flame.

**DE** Verkleidung mit Sockel aus handgearbeiteter Majolika, völlig fugenlos und in meisterhafter Ausführung aus einem einzigen Element gefertigt. In einer großen Auswahl von Farben erhältlich. Aufsatz aus beliebig einfärbbarem Marmor. Der an drei Seiten verglaste Feuerraum bietet eine perfekte Sicht auf das Feuer.

**FR** Revêtement avec base en faïence façonnée à la main sans aucun raccord, créée à partir d'un unique élément grâce à une technique de réalisation très recherchée. Disponible dans une large gamme de couleurs. Rehausse en marbre à teinter au gré de ses envies. Foyer à trois vitres pour une vision parfaite de la flamme.

**ES** Revestimiento con base de mayólica trabajada a mano, sin puntos de unión, obtenida a partir de un único elemento, gracias a una realización esmerada. Disponible en una amplia gama de colores. Realce de mármol para pintar al gusto. Hogar de tres vidrios para una perfecta visión de la llama.



## COLORI - COLOURS

Ardesia	Tabacco
Bianco Antico	Terra Cotta
Bianco Grigio	Tortora
Kaki	
Mattone	
Sahara	
Senape	



→ Colori - Colours P.19

→ Focolari compatibili - Compatible fireboxes P.242



# ABERDEEN

**Rivestimento con base in Maiolica disponibile in un'ampia gamma di colori. La soluzione compatta del rivestimento consente di collocarlo in una diversità di ambienti. È particolarmente adatto per ambienti di medie dimensioni. Il focolare a tre vetri rende perfetta la visione della fiamma, anche da differenti punti dell'ambiente. Rialzo in marmo tinteggiabile.**

**EN** Surround with majolica base available in a wide range of colours. Thanks to its compact surround, the product can be installed in various environments. It is particularly suited to medium-sized rooms. The firebox with three glass panels guarantees an optimal view of the flame, even from different points of the room. Coatable marble riser.

**DE** Verkleidung mit Sockel aus Majolika, in großer Farbauswahl erhältlich. Die kompakte Lösung der Verkleidung ermöglicht die Anordnung in unterschiedlichen Räumen. Besonders geeignet für mittelgroße Räume. Der dreiseitig verglaste Feuerraum bietet eine perfekte Sicht auf die Flammen auch aus unterschiedlichen Positionen. Aufsatz aus färbbarem Marmor.

**FR** Revêtement avec base en faïence disponible dans de nombreuses couleurs. Cette solution compacte peut être installée dans les pièces les plus diverses et est particulièrement adaptée aux pièces de dimensions moyennes. Le foyer à trois vitres permet une vision parfaite de la flamme, depuis différents angles de la pièce. Rehausse en marbre à teinter.

**ES** Revestimiento con base de mayólica disponible en una amplia gama de colores. La solución compacta del revestimiento permite colocarlo en una gran variedad de ambientes. Apto sobre todo para ambientes medianos. El hogar con tres vidrios ofrece una perfecta visión de la llama, aun desde distintos puntos de la habitación. Realce de mármol pintable.



## COLORI - COLOURS

Ardesia	Tabacco
Bianco Antico	Terra Cotta
Bianco Grigio	Tortora
Kaki	
Mattone	
Sahara	
Senape	



→ Colori - Colours P.19

→ Focolari compatibili - Compatible fireboxes P.240





# CARDIFF

**Rivestimento con panca e mensola in Maiolica lavorata a mano disponibile in un'ampia gamma di colori. Rialzo in marmo tinteggiabile a piacere. La particolare forma del vetro tri-facciale, rende questo caminetto in grado di esaltare il piacere del fuoco facendolo condividere da più prospettive di ambiente.**

**EN** The surround includes a bench and shelf made of hand-crafted majolica, available in a wide range of colours. Coatable marble riser. Thanks to the special shape of the three-sided glass, this fireplace enhances the pleasure of fire, which can be appreciated from various points in the room.

**DE** Verkleidung mit Sitzbank und Konsole aus handgefertigter Majolika, in einer großen Auswahl von Farben erhältlich. Aufsatz aus beliebig einfarbbarem Marmor. Die besondere Form der dreiseitigen Scheibe ermöglicht den Genuss des Feuers aus mehreren Perspektiven des Raums.

**FR** Revêtement avec banquette et étagère en faïence façonnée à la main disponible dans une large gamme de couleurs. Rehausse en marbre à teinter au gré de ses envies. La forme particulière de la vitre présente sur trois faces permet à cette cheminée d'exalter le plaisir du feu en le faisant partager à tous depuis plusieurs perspectives de la pièce.

**ES** Revestimiento con banco y repisa de mayólica trabajada a mano disponible en una amplia gama de colores. Realce de mármol para pintar al gusto. La forma especial del vidrio de tres caras permite a la chimenea exaltar el placer del fuego con la posibilidad de compartirlo desde varios puntos del ambiente.



## COLORI - COLOURS

Ardesia	Tabacco
Bianco Antico	Terra Cotta
Bianco Grigio	Tortora
Kaki	
Mattone	
Sahara	
Senape	



WOOD



AIR



THERMO

→ Colori - Colours P.19

→ Focolari compatibili - Compatible fireboxes P.240



# BRISTOL con panca with bench

**Rivestimento con base realizzata in un unico elemento in Maiolica fatta a mano e panca. Rialzo e spalle in marmo tinteggiabili a piacere. Focolare con vetro ad angolo che rende emozionante e suggestiva la visione della fiamma. Disponibile in versione destra o sinistra.**

**EN** The surround includes a base consisting of a single-piece hand-crafted majolica element and bench. Marble riser and side supports coatable as desired. Firebox with corner glass for an enchanting view of the flame. Available in the right-hand or left-hand version.

**DE** Verkleidung mit Sockel aus einem einzigen Element aus handgefertigter Majolika und Sitzbank. Aufsatz und Seitenteile aus beliebig einfarbbarem Marmor. Feuerraum mit Scheibe über Eck, die die Sicht auf die Flamme aufregend und stimmungsvoll macht. Als Rechts- oder Links-Version erhältlich.

**FR** Revêtement avec base réalisée d'un seul tenant en faïence façonnée à la main et banquette. Rehausse et rebords en marbre à teinter au gré de ses envies. Foyer avec vitre en angle pour une vision de la flamme évocatrice et source d'émotion. Disponible en version droite ou gauche.

**ES** Revestimiento con base realizada en un único elemento de mayólica hecha a mano y banco. Realce y paneles laterales de mármol para pintar al gusto. Hogar con vidrio en esquina que llena de emoción y encanto la visión de la llama. Disponible en versión derecha o izquierda.



#### COLORI - COLOURS

Ardesia	Tabacco
Bianco Antico	Terra Cotta
Bianco Grigio	Tortora
Kaki	
Mattone	
Sahara	
Senape	



→ Colori - Colours P.19

→ Focolari compatibili - Compatible fireboxes P.240



# BRISTOL

**Rivestimento con base realizzata in un unico elemento in Maiolica fatta a mano disponibile in un'ampia gamma di colori. Rialzo e spalle in marmo tinteggiabili a piacere. Focolare con vetro ad angolo che rende emozionante e suggestiva la visione della fiamma. Disponibile in versione destra o sinistra.**

**EN** The surround includes a base consisting of a single-piece hand-crafted majolica element available in a wide range of colours. Marble riser and side supports coatable as desired. Firebox with corner glass for an enchanting view of the flame. Available in the right-hand or left-hand version.

**DE** Verkleidung mit Sockel aus einem einzigen Element aus handgefertigter Majolika, in einer großen Auswahl von Farben erhältlich. Aufsatz und Seitenteile aus beliebig einfärbbarem Marmor. Feuerraum mit Scheibe über Eck, die die Sicht auf die Flamme aufregend und stimmungsvoll macht. Als Rechts- oder Links-Version erhältlich.

**FR** Revêtement avec base réalisée d'un seul tenant en faïence façonnée à la main disponible dans une large gamme de couleurs. Rehausse et rebords en marbre à teinter au gré de ses envies. Foyer avec vitre en angle pour une vision de la flamme évocatrice et source d'émotion. Disponible en version droite ou gauche.

**ES** Revestimiento con base realizada en un único elemento de mayólica hecha a mano, disponible en una amplia gama de colores. Realce y paneles laterales de mármol para pintar al gusto. Hogar con vidrio en esquina que llena de emoción y encanto la visión de la llama. Disponible en versión derecha o izquierda.



## COLORI - COLOURS

Ardesia	Tabacco
Bianco Antico	Terra Cotta
Bianco Grigio	Tortora
Kaki	
Mattone	
Sahara	
Senape	



→ Colori - Colours P.19

→ Focolari compatibili - Compatible fireboxes P.240



# CANBERRA

**Linee verticali e orizzontali si incontrano e incorniciano il fuoco, volumi diversi lo accolgono. Le qualità della Maiolica, materia viva e calda, che accumula e diffonde il calore del fuoco, sono valorizzate da un decoro elegante dal segno deciso. Disponibile in un'ampia gamma colori sia nelle versione monocolora che bicolore a richiesta.**

**EN** Vertical and horizontal lines clash to envelop the fire with variously shaped masses. The properties of majolica – a warm, live material – which stores and releases the heat of the fire, are enhanced by the elegant decoration featuring clean lines. Available in a wide range of colours in both the monochrome or two-coloured version on request.

**DE** Vertikale und horizontale Linien treffen aufeinander und umrahmen das Feuer mit verschiedenen Formen. Die Eigenschaften der Majolika - eine lebendige und warme Materie, die Wärme speichert und abstrahlt - werden durch elegantes Dekor mit starkem Charakter betont. Erhältlich in großer Farbauswahl, in ein- und, auf Anfrage, in zweifarbiger Version.

**FR** Lignes verticales et horizontales se rencontrent et encadrent le feu, accueilli par des volumes divers. Les qualités de la faïence, matériau vif et chaud, qui accumule et diffuse la chaleur du feu, sont mises en valeur par un décor élégant et affirmé. Disponible dans de nombreuses couleurs, en version d'une seule couleur ou bicolore sur demande.

**ES** Líneas verticales y horizontales se encuentran y enmarcan el fuego, acogido por distintos volúmenes. Un toque elegante de carácter resuelto valoriza las virtudes de la mayólica, materia viva y cálida que acumula y difunde el calor del fuego. Disponible en una amplia gama de colores, en versión tanto monocolor como bicolor bajo pedido.



## COLORI - COLOURS

Ardesia	Senape	Sahara/Bianco Antico
Bianco	Tabacco	Terra Cotta/Bianco Antico
Bianco Antico	Terra Cotta	Tortora/Bianco Antico
Bianco Grigio	Tortora	
Kaki		
Mattone		
Sahara		



→ Colori - Colours P.19

→ Focolari compatibili - Compatible fireboxes P.240







# DARWIN

**Contrasti di colori finiture e forme asimmetriche caratterizzano questa cornice in pregiata Maiolica. Le diverse proporzioni delle due parti della cornice, rendono originale il suo design, le incisioni su un lato della cornice impreziosiscono e valorizzano la Maiolica. Disponibile in versione monocolor o bicolore su richiesta; anche in versione bifacciale.**

**EN** Contrasting colours and finishes, combined with asymmetrical forms, define this refined majolica frame. The different proportions of the two frame elements yield an original design, the engraving on one side of the frame enhances the majolica. Available in the monochrome or two-coloured version on request, and in the double-face version.

**DE** Kontraste in Farbe und Oberfläche und asymmetrische Formen kennzeichnen diese Einfassung aus hochwertiger Majolika. Unterschiedliche Proportionen der zwei Teile erzeugen ein originelles Design, Gravuren an einer Seite der Einfassung werten die Majolika zusätzlich auf. Erhältlich in ein- bzw. auf Anfrage in zweifarbigter Version, sowie zweiseitig.

**FR** Cadre en faïence de haute qualité aux couleurs contrastées et aux formes asymétriques. Les deux parties aux proportions différentes lui donnent un design original et les gravures présentes d'un seul côté enrichissent et exaltent la faïence. Disponible en version d'une seule couleur ou bicolore sur demande ; également disponible en version double face.

**ES** Contrastes de colores, acabados y formas asimétricas caracterizan este marco de preciaada mayólica. Las distintas proporciones de las dos partes del marco dan originalidad al diseño; los grabados en uno de los lados del marco embellecen y valorizan la mayólica. Disponible en versión monocolor o bicolor bajo pedido, también en versión de doble cara.



## COLORI - COLOURS

Ardesia	Senape	Sahara/Bianco Grigio
Bianco	Tabacco	Terra Cotta/Bianco Grigio
Bianco Antico	Terra Cotta	Tortora/Bianco Grigio
Bianco Grigio	Tortora	
Kaki		
Mattone		
Sahara		



→ Colori - Colours P.19

→ Focolari compatibili - Compatible fireboxes P.241



# MELBOURNE

**Due forme si incontrano e fondono a racchiudere il fuoco. Pannelli di Maiolica di grandi dimensioni si accostano tra loro. Nella versione bicolore viene evidenziata la forma. Disponibile in una molteplicità di colori sia nelle versione monocolori che bicolore anche a richiesta. A legna e pellet anche thermo.**

**EN** Two forms clash and merge to envelop the fire. Large-size majolica panels are juxtaposed. The shape of the fireplace is enhanced in the two-colour version. Wide assortment of colours, either monochrome or two-colour version on request. Wood-burning or pellet-burning, also in the Thermo version.

**DE** Zwei Formen treffen aufeinander und verschmelzen, um das Feuer zu umschließen. Große Majolika-Platten passen sich einander an. Die zweifarbige Version unterstreicht die Form. Erhältlich in großer Farbenvielfalt, sowohl in ein- als auch in zweifarbiger Version, auch auf Anfrage. Für Holz- und Pelletfeuerung, auch als Thermo-Version.

**FR** Le feu est entouré de deux formes qui se rencontrent et se mélangent, dans une association de panneaux de faïence de grandes dimensions. Dans la version bicolore, la forme se trouve exaltée. Modèle disponible dans une foule de couleurs, d'une seule couleur ou en version bicolore sur demande. Version à bois et granulés, mais aussi thermo.

**ES** Dos formas se encuentran y se unen para contener el fuego. Paneles de mayólica de grandes dimensiones uno junto a otro. En la versión bicolor se exalta la forma. Disponible en numerosos colores tanto en la versión monocolor como en la versión bicolor, también bajo pedido. Versión de leña, pellets y Thermo.



## COLORI - COLOURS

Ardesia	Senape	Senape/Bianco Antico
Bianco	Tabacco	Terra Cotta/Bianco Antico
Bianco Antico	Terra Cotta	Tortora/Bianco Antico
Bianco Grigio	Tortora	
Kaki		
Mattone		
Sahara		



→ Colori - Colours P.19

→ Focolari compatibili - Compatible fireboxes P.242



# ADELAIDE

**La Maiolica, lavorata a mano, in grande formato e dallo spessore importante, dona prestigio a questo rivestimento dalle linee essenziali e decise. Il focolare centrale è il cuore del caminetto, l'ampia superficie in Maiolica lo incornicia con eleganza e accumula il calore rilasciandolo poi confortevolmente anche dopo lo spegnimento.**

**EN** The large, hand-worked and thick majolica panels add a refined touch to a sober, distinct surround. The central firebox is the heart of the fireplace, the broad majolica surface frames it elegantly and harnesses the heat which it then releases after the switch-off, for even greater comfort.

**DE** Die handgefertigte Majolika in großem Format und hoher Wanddicke verleiht dieser Verkleidung mit ihren nüchternen, klaren Linien Prestige. Der zentrale Feuerraum ist das Herz des Kamins, die große Majolika-Fläche umrahmt ihn mit Eleganz und speichert die Wärme, um diese dann auf angenehme Weise auch nach dem Erlöschen wieder freizugeben.

**FR** La faïence façonnée à la main, de grand format et de forte épaisseur, offre un aspect prestigieux à ce revêtement aux lignes essentielles et décidées. Le foyer central est le cœur de la cheminée, tandis que la grande surface en faïence l'encadre avec élégance et accumule la chaleur pour la libérer ensuite alors même que le feu est éteint.

**ES** La mayólica, trabajada a mano, en formato grande y con un espesor relevante, da prestigio a este revestimiento de líneas esenciales y resueltas. El hogar central es el corazón de la chimenea; la amplia superficie de mayólica lo enmarca con elegancia y acumula el calor para liberarlo luego confortablemente incluso tras el apagado.



## COLORI - COLOURS

Ardesia	Senape
Bianco	Tabacco
Bianco Antico	Terra Cotta
Bianco Grigio	Tortora
Kaki	
Mattone	
Sahara	



→ Colori - Colours P.19

→ Focolari compatibili - Compatible fireboxes P.240



# PRESTON

**Rivestimento con base, frontale e mensole in Maiolica disponibile in un'ampia gamma di colori. Telaio in acciaio verniciato nero. Una composizione di elementi in grado di caratterizzare una parete, sapendosi anche inserire in un più ampio progetto di arredo.**

**EN** Surround with base, front and shelves made of majolica, available in a wide range of colours. Black-coated steel frame. A composition with elements capable of defining a wall and ably blending into the wider furnishing context.

**DE** Verkleidung mit Sockel, Front und Konsolen aus Majolika, in großer Farbauswahl erhältlich. Rahmen aus schwarz lackiertem Stahl. Die Komposition aus verschiedenen Elementen kann zum Mittelpunkt einer Wand werden, sich aber auch in ein größeres Einrichtungsprojekt einfügen.

**FR** Revêtement avec base, façade et étagères en faïence disponible dans une large gamme de couleurs. Cadre en acier peint noir. Un ensemble d'éléments qui sauront donner un aspect unique à votre mur, mais aussi s'intégrer dans un projet de décoration d'intérieur plus vaste.

**ES** Revestimiento con base, frente y repisas de mayólica, disponible en una amplia gama de colores. Bastidor de acero pintado negro. Una composición de elementos capaces de caracterizar una pared, y de integrarse asimismo en un proyecto de decoración más completo.



## COLORI - COLOURS

Ardesia	Tabacco
Bianco Antico	Terra Cotta
Bianco Grigio	Tortora
Kaki	
Mattone	
Sahara	
Senape	



→ Colori - Colours P.19

→ Focolari compatibili - Compatible fireboxes P.242





# LINZ

**Rivestimento e pannello frontale in Maiolica lavorata a mano. Decorazioni a bassorilievo sull'anta che racchiude un vano porta oggetti. Disponibile nelle versioni monocolor e bicolore e in versione bifacciale per una visione della fiamma da entrambi i lati.**

**EN** Surround and front panel made of hand-crafted majolica. Bas-relief decorations on the door which covers a storage compartment. Available in the monochrome and two-colour versions, and also double-face, for viewing the flame from both sides.

**DE** Verkleidung und Frontplatte aus handgearbeiteter Majolika. Basrelief-Dekors auf der Tür, hinter der sich ein Ablagefach verbirgt. Erhältlich in ein- und zweifarbigen Versionen und als zweiseitige Version für die Sicht auf die Flammen von beiden Seiten.

**FR** Revêtement et façade en faïence façonnée à la main. décors sculptés en bas-relief sur la porte qui dissimule une niche à objets. Modèle disponible en version d'une seule couleur et bicolore, et en version double face permettant d'admirer la flamme des deux côtés.

**ES** Revestimiento y panel frontal de mayólica trabajada a mano. Decoraciones en bajorrelieve en la puerta que encierra un compartimento portaobjetos. Disponible en las versiones monocolor y bicolor y en versión de doble cara para una visión de la llama desde los dos lados.



#### COLORI - COLOURS

Bianco Grigio  
Grigio Ferro/Bianco Grigio  
Grigio Ferro/Giallo Acceso



→ Colori - Colours P.19

→ Focolari compatibili - Compatible fireboxes P.242



# GRAZ

**Originale rivestimento in Maiolica lavorata a mano con ampi pannelli scorrevoli, ricercati nella lavorazione, che chiudono due funzionali vani porta oggetti. Il rivestimento è disponibile per un'ampia gamma di focolari a legna, anche in versione bifacciale, per una visione della fiamma da entrambi i lati.**

**EN** Highly original hand-crafted majolica surround with broad, finely worked sliding panels that enclose two functional storage compartments. The surround is compatible with an extensive range of wood-burning fireboxes, also in the double-face version, for viewing the flame from both sides.

**DE** Originelle Verkleidung aus handgearbeiteter Majolika mit breiten verschiebbaren Platten, erlesen in der Verarbeitung, hinter denen sich zwei praktische Ablagefächer verbergen. Die Verkleidung ist für eine große Auswahl von Feuerräumen für Holzfeuerung erhältlich, auch als zweiseitige Version, für die Sicht auf die Flammen von beiden Seiten.

**FR** Revêtement original en faïence façonnée à la main accompagné de grands panneaux coulissants à la réalisation recherchée, qui permettent de fermer deux niches à objets très pratiques. Le revêtement est compatible avec une large gamme de foyers à bois, aussi en version double face, pour permettre d'admirer la flamme des deux côtés.

**ES** Original revestimiento de mayólica trabajada a mano con amplios paneles correderos, elaborados con esmero, que encierran dos funcionales compartimentos portaobjetos. Revestimiento disponible para una amplia gama de hogares de leña, también en versión de doble cara para una visión de la llama desde los dos lados.



#### COLORI - COLOURS

Bianco Antico  
Giallo Acceso  
Grigio Cerato  
Rosso Lava



→ Colori - Colours P.19

→ Focolari compatibili - Compatible fireboxes P.242



# PHILADELPHIA

**Spettacolare cornice in Maiolica fatta a mano per questo rivestimento con piccola texture impreziosita da cristallina. Disponibile, oltre che nei colori della famiglia Basic anche con le pregiate finiture delle linee Elegance e Luxury. In foto la finitura Platino.**

**EN** A spectacular hand-made majolica frame for this surround, featuring a tightly-knit texture enriched by crystalline. Available in the colours of the Basic range and also with the refined finishes of the Elegance and Luxury ranges. The picture shows the Platino version.

**DE** Grandiose Einfassung aus handgefertigter Majolika für diese Verkleidung mit kleinteiliger Oberflächenstruktur, durch Transparentglasur verziert. In den Farben der Basic-Familie sowie mit den edlen Oberflächenfinishes der Linien Elegance und Luxury erhältlich. Auf dem Foto das Finish Platino.

**FR** Ce cadre spectaculaire en faïence façonnée à la main présente un revêtement finement texturé agrémenté d'émail. Outre les couleurs de la famille Basic, ce modèle est aussi disponible dans les finitions précieuses des lignes Elegance et Luxury. En photo, la finition Platino.

**ES** Espectacular marco de mayólica trabajada a mano para este revestimiento con una pequeña textura embellecida con esmalte vítreo. Disponible en los colores de la familia Basic y con los preciados acabados de las líneas Elegance y Luxury. En la foto, el acabado Platino.



#### COLORI - COLOURS

Linea Basic  
Linea Elegance  
Linea Luxury

→ Dettagli - Details P.178



→ Colori - Colours P.19, P.21

→ Focolari compatibili - Compatible fireboxes P.242



# COLUMBIA

**Rivestimento in Maiolica artisticamente lavorata a mano. L'esempio in foto che fa parte della linea Luxury ha una finitura setolata impreziosita da dettagli pennellati in cristallina Argento su pannello laterale. È disponibile anche in versione bifacciale per godere del piacere della fiamma da entrambi i lati.**

**EN** Artistically hand-crafted majolica surround. The example shown in the picture, belonging to the Luxury range, has a bristly finish enriched by brushed silver crystalline details on the side panel. Also available in the double-face version to admire the flame from both sides.

**DE** Verkleidung aus künstlerisch handgearbeiteter Majolika. Das Beispiel auf dem Foto, das Teil der Luxury-Linie ist, hat eine gebürstete Oberfläche, veredelt durch Pinselstrichdetails in Argento Transparentglasur auf dem Seitenpaneel. Auch erhältlich in zweiseitiger Version, um den Anblick des Feuers von beiden Seiten genießen zu können.

**FR** Revêtement en faïence façonnée à la main avec art. L'exemple de la photo appartient à la ligne Luxury et possède une finition brossée agrémentée de détails en émail Argento appliqués au pinceau sur le panneau latéral. Ce modèle est également disponible en version double face pour profiter du plaisir de la flamme des deux côtés.

**ES** Revestimiento de mayólica trabajada a mano artísticamente. El ejemplo de la foto, parte de la línea Luxury, tiene un acabado bruzado embellecido con detalles pincelados en esmalte vítreo Argento en el panel lateral. Disponible también en versión de doble cara para disfrutar del placer de la llama desde los dos lados.



#### COLORI - COLOURS

Linea Basic  
Linea Elegance  
Linea Luxury

→ Dettagli - Details P.176



→ Colori - Colours P.19, P.21

→ Focolari compatibili - Compatible fireboxes P.241





# VILLAGE

**Il fascino di un elemento di arredo molto particolare, che si sa distinguere. In foto Maiolica finitura Rame Decorato, impreziosita dal particolare in cristallino tono su tono su pannello superiore. Disponibile, oltre che nei colori della famiglia Basic anche con le pregiate finiture delle linee Elegance e Luxury.**

**EN** The allure of a highly distinctive furnishing element. The picture shows the majolica with Rame Decorato finish, enriched by the tone-on-tone crystalline detail on the upper panel. Available in the colours of the Basic range and also with the refined finishes of the Elegance and Luxury ranges.

**DE** Die Faszination eines ganz besonderen Einrichtungselements, das sich auszuzeichnen weiß. Auf dem Foto Majolika mit Oberflächenfinish Rame Decorato, veredelt durch das Detail aus Transparentglasur Ton in Ton auf dem oberen Paneel. In den Farben der Basic-Familie sowie mit den edlen Oberflächenfinishs der Linien Elegance und Luxury erhältlich.

**FR** Le charme d'un élément décoratif très particulier, qui sait sortir du lot. En photo, version en faïence finition Rame Decorato, ornée sur le panneau supérieur d'un détail en émail ton sur ton. Outre les couleurs de la famille Basic, ce modèle existe aussi dans les finitions précieuses des lignes Elegance et Luxury.

**ES** El encanto de un elemento de decoración muy singular, que sabe hacerse reconocer. En la foto, mayólica con acabado Cobre Decorado, embellecida con el detalle en esmalte vítreo tono sobre tono en el panel superior. Disponible en los colores de la familia Basic y con los preciados acabados de las líneas Elegance y Luxury.



#### COLORI - COLOURS

Linea Basic  
Linea Elegance  
Linea Luxury

→ Dettagli - Details P.179



→ Colori - Colours P.19, P.21

→ Focolari compatibili - Compatible fireboxes P.243



# CITY

**Caminetto con rivestimento in pregiata Maiolica lavorata a mano. Disponibile, oltre che nei colori della famiglia Basic anche con le pregiate finiture delle linee Elegance e Luxury, esempio della più elevata maestria della lavorazione della Maiolica. In foto la finitura Oro, con decoro oro Damascato.**

**EN** A fireplace featuring refined, hand-crafted majolica surround. Available in the colours of the Basic range and in the refined finishes of the Elegance and Luxury ranges, the ultimate in majolica craftsmanship. The picture shows the Oro finish with Oro Damascato decoration.

**DE** Kamin mit Verkleidung aus edler, handgearbeiteter Majolika. In den Farben der Basic-Familie sowie mit den edlen Oberflächenfinishes der Linien Elegance und Luxury erhältlich, Beispiel für meisterhafte Majolika-Arbeiten. Auf dem Foto das Finish Oro mit Gold-Dekor Damascato.

**FR** Cheminée revêtue de faïence de haute qualité façonnée à la main. Outre les couleurs de la famille Basic, ce modèle est aussi disponible dans les finitions précieuses des lignes Elegance et Luxury. Un exemple de l'immense maîtrise du travail de la faïence, exaltée par l'aspect précieux des décors. En photo, la finition Oro, avec décor Oro Damascato.

**ES** Chimenea con revestimiento de preciada mayólica trabajada a mano. Disponible en los colores de la familia Basic y con los preciados acabados de las líneas Elegance y Luxury, ejemplo de la más alta maestría en la realización de la mayólica. En la foto, el acabado Oro, con decoración en Oro Damascato.



#### COLORI - COLOURS

Linea Basic  
Linea Elegance  
Linea Luxury

→ Dettagli - Details P.176



→ Colori - Colours P.19, P.21

→ Focolari compatibili - Compatible fireboxes P.240



# EASY

**Un rivestimento con cornice in Maiolica lavorata a mano che rappresenta una soluzione in grado di poter accogliere il maggior numero di alternative possibili nella scelta del focolare a legna o a pellet, anche in versione Thermo. È disponibile anche in versione bifacciale per una visione della fiamma da entrambi i lati.**

**EN** Surround with hand-crafted majolica frame for a solution capable of accommodating as many alternatives as possible among wood-burning or pellet-burning fireboxes, even in the Thermo version. Also available in the double-face version for viewing the flame from both sides.

**DE** Diese Verkleidung mit Einfassung aus handgearbeiteter Majolika stellt eine Lösung dar, die die größtmögliche Zahl an Alternativen bei der Wahl des Feuerraums für Holz- oder Pelletfeuerung aufnehmen kann, auch als Thermo-Version. Sie ist auch als zweiseitige Version erhältlich, um die Sicht auf das Feuer von beiden Seiten zu ermöglichen.

**FR** Un revêtement avec cadre en faïence façonnée à la main qui représente une solution en mesure d'accueillir une foule d'alternatives : foyers à bois ou à granulés, également en version thermo. Il est aussi disponible dans une version double face permettant d'admirer la flamme des deux côtés.

**ES** Un revestimiento con marco de mayólica trabajada a mano que representa una solución capaz de acoger el mayor número de alternativas posibles en la elección del hogar de leña o de pellets, también en versión Thermo. Disponible también en versión de doble cara para una visión de la llama desde los dos lados.



#### COLORI - COLOURS

Grigio Ferro  
Moka  
Neve



→ Colori - Colours P.19

→ Focolari compatibili - Compatible fireboxes P.241



# LIPSIA

**Pannelli in Maiolica lavorata a mano dalla morbida curvatura, per questo originale caminetto disponibile in vari colori. Profilo in acciaio verniciato grigio o nero a scelta. Il focolare può essere scelto anche in versione bifacciale per una visione della fiamma da entrambi i lati.**

**EN** Softly curving hand-crafted majolica panels for a highly original fireplace available in various colours. Steel profile coated either grey or black. The firebox is also available in the double-face version, for viewing the flame from both sides.

**DE** Platten aus handgearbeiteter Majolika mit sanft geschwungener Oberfläche, für diesen originellen Kamin in verschiedenen Farben erhältlich. Profil aus wahlweise grau oder schwarz lackiertem Stahl. Der Feuerraum kann auch als zweiseitige Version für die Sicht auf die Flammen von beiden Seiten gewählt werden.

**FR** Panneaux en faïence façonnée à la main délicatement incurvés, pour cette cheminée originale disponible en différentes couleurs. Profil en acier peint gris ou noir au choix. Le foyer peut être choisi également en version double face, pour pouvoir admirer la flamme des deux côtés.

**ES** Paneles de mayólica trabajada a mano con un suave curvado, para esta original chimenea disponible en varios colores. Perfil de acero pintado gris o negro, según la elección. El hogar puede escogerse también en versión de doble cara para una visión de la llama desde los dos lados.



## COLORI - COLOURS

Bianco Grigio  
Bruno Rame  
Giallo Acceso  
Grigio Cerato  
Rosso Lava



→ Colori - Colours P.19

→ Focolari compatibili - Compatible fireboxes P.242





# AMBURGO

**Rivestimento in Maiolica lavorata a mano, caratterizzata anche da pregiate decorazioni in bassorilievo. Sul retro del pannello curvato di sinistra è possibile applicare un led offrendo una ulteriore fascino all'ambiente. Disponibile anche in versione bifacciale per una visione della fiamma da entrambi i lati.**

**EN** Hand-worked majolica surround, featuring refined bas-relief decorations. A LED can be applied to the rear of the left-hand curved panel to further enhance the setting's charm. Also available in the double-face version for viewing the flame from both sides.

**DE** Verkleidung aus handgefertigter Majolika mit edlen Basrelief-Dekors. An der Rückseite der linken gebogenen Kachel kann eine LED-Leuchte angebracht werden, die dem Raum zusätzlichen Charme verleiht. Auch erhältlich als zweiseitige Version für die Sicht auf die Flammen von beiden Seiten.

**FR** Revêtement en faïence façonnée à la main, caractérisé par de beaux décors sculptés en bas-relief. Sur l'arrière du panneau incurvé de gauche, il est possible d'appliquer un éclairage à LED qui ajoutera un charme supplémentaire à la pièce. Disponible également version double face assurant la vision de la flamme des deux côtés.

**ES** Revestimiento de mayólica trabajada a mano, caracterizada también por precias decoraciones en bajorrelieve. En la parte posterior del panel curvado de la izquierda se puede aplicar un led para ofrecer más encanto al ambiente. Disponible también en versión de doble cara para una visión de la llama desde los dos lados.



## COLORI - COLOURS

Bianco Antico  
Bruno Rame  
Giallo Acceso  
Grigio Cerato  
Rosso Lava



→ Colori - Colours P.19

→ Focolari compatibili - Compatible fireboxes P.240



# FRIBURGO

**Caminetto con Cornice in Maiolica lavorata a mano, con decorazioni in bassorilievo, profilo in acciaio verniciato nero. Disponibile per una vasta gamma di focolari a legna anche in versione bifacciale per una visione della fiamma da entrambi i lati, e Thermo.**

**EN** A fireplace with a hand-crafted frame, featuring bas-relief decorations and a black-coated steel profile. Compatible with a wide variety of wood-burning fireboxes, also available in the double-face version, for viewing the flame from both sides, and in the Thermo version.

**DE** Kamin mit Einfassung aus handgearbeiteter Majolika, mit Basrelief-Dekors, Profil aus schwarz lackiertem Stahl. Erhältlich für eine reichhaltige Auswahl von Feuerräumen für Holzfeuerung, auch als zweiseitige Version für die Sicht auf die Flammen von beiden Seiten, sowie als Thermo-Version.

**FR** Cheminée avec cadre en faïence façonnée à la main, avec décors sculptés en bas-relief et profil en acier peint noir. Modèle compatible avec une vaste gamme de foyers à bois, également disponible en version double face pour une vision de la flamme des deux côtés, et en version thermo.

**ES** Chimenea con marco de mayólica trabajada a mano, con decoraciones en bajorrelieve y perfil de acero pintado negro. Disponible para una amplia gama de hogares de leña, también en versión de doble cara para una visión de la llama desde los dos lados, y en la versión Thermo.



## COLORI - COLOURS

Bianco Antico  
Bruno Rame  
Giallo Acceso  
Grigio Cerato  
Rosso Lava



→ Colori - Colours P.19

→ Focolari compatibili - Compatible fireboxes P.242



# SIGNS

**Significativo esempio dell'abilità artigianale nella lavorazione della Maiolica sapientemente realizzata. Superficie con decori che la impreziosiscono e dettagli in cristallina. Disponibile, oltre che nei colori della famiglia Basic anche con le pregiate finiture delle linee Elegance e Luxury. Anche bifacciale.**

**EN** A prime example of the skilled craftsmanship characterising the finely worked majolica. Surfaces enriched by decorations and crystalline details. Available in the colours of the Basic range and also with the refined finishes of the Elegance and Luxury ranges. Double-face version available.

**DE** Bedeutendes Beispiel für das handwerkliche Geschick bei der Majolika-Verarbeitung in meisterhafter Ausführung. Oberfläche mit edlen Dekors aus Transparentglasur. In den Farben der Basic-Familie sowie mit den edlen Oberflächenfinishes der Linien Elegance und Luxury erhältlich. Auch zweiseitig.

**FR** Un parfait exemple de maîtrise artisanale, grâce à la faïence savamment réalisée. Surface ornée de décors et de détails en émail. Outre les couleurs de la famille Basic, ce modèle existe aussi dans les finitions précieuses des lignes Elegance et Luxury. Disponible également en version double face.

**ES** Ejemplo significativo de la habilidad artesanal en la elaboración de la mayólica sabiamente realizada. Superficie con decoraciones que la embellecen y detalles de esmalte vítreo. Disponible en los colores de la familia Basic y con los preciados acabados de las líneas Elegance y Luxury. También en doble cara.



## COLORI - COLOURS

Linea Basic  
Linea Elegance  
Linea Luxury

→ Dettagli - Details P.178



→ Colori - Colours P.19, P.21

→ Focolari compatibili - Compatible fireboxes P.243



# PHOENIX

**Originale e particolarmente elegante cornice in Maiolica lavorata a mano impreziosita da cristallina su caratterizzanti mezzelune laterali in bassorilievo. Disponibile, oltre che nei colori della famiglia Basic anche con le pregiate finiture delle linee Elegance e Luxury.**

**EN** An original and highly elegant hand-crafted majolica frame, enriched by crystalline on distinctive bas-relief crescents lining each side. Blasted steel riser and profiles. Available in the colours of the Basic range and also with the refined finishes of the Elegance and Luxury ranges.

**DE** Originelle und besonders elegante Einfassung aus handgearbeiteter Majolika mit Transparentglasur-Verzierung an charakteristischen seitlichen Halbmonden in Basrelief. In den Farben der Basic-Familie sowie mit den edlen Oberflächenfinishes der Linien Elegance und Luxury erhältlich.

**FR** Particulièrement original et élégant, ce cadre en faïence façonnée à la main est orné sur les côtés de demi-lunes caractéristiques sculptées en bas-relief et émaillées. Outre les couleurs de la famille Basic, ce modèle est aussi disponible dans les finitions précieuses des lignes Elegance et Luxury.

**ES** Marco original y particularmente elegante de mayólica trabajada a mano, embellecido con esmalte vítreo en las singulares medialunas laterales en bajorrelieve. Disponible en los colores de la familia Basic y con los preciados acabados de las líneas Elegance y Luxury.



#### COLORI - COLOURS

Linea Basic  
Linea Elegance  
Linea Luxury

→ Dettagli - Details P.178



→ Colori - Colours P.19, P.21

→ Focolari compatibili - Compatible fireboxes P.242





# SALISBURGO

**Cornice in Maiolica lavorata a mano con decorazioni in bassorilievo. Il Design asimmetrico slancia le sue linee rendendo particolarmente interessante il gioco della prospettiva. Disponibile anche in versione bifacciale per una visione della fiamma da entrambi i lati.**

**EN** Hand-crafted majolica frame with bas-relief decorations. The asymmetrical forms streamline the design and create a striking perspective effect. Also available in the double-face version, for viewing the flame from both sides.

**DE** Einfassung aus handgearbeiteter Majolika mit Basrelief-Dekors. Das asymmetrische Design verjüngt seine Linien und macht das Spiel mit der Perspektive besonders interessant. Auch als zweiseitige Version für die Sicht auf die Flammen von beiden Seiten erhältlich.

**FR** Cadre en faïence façonnée à la main avec décors sculptés en bas-relief. Le design asymétrique donne un aspect plus élancé à ses lignes, rendant ainsi particulièrement intéressant le jeu de perspective. Disponible également dans une version double face qui permet d'admirer la flamme des deux côtés.

**ES** Marco de mayólica trabajada a mano con decoraciones en bajorrelieve. El diseño asimétrico estiliza sus líneas dando un toque particularmente interesante al juego de la perspectiva. Disponible también en versión de doble cara para una visión de la llama desde los dos lados.



## COLORI - COLOURS

Bianco Antico  
Bruno Rame  
Grigio Cerato



→ Colori - Colours P.19

→ Focolari compatibili - Compatible fireboxes P.243



# VIENNA

**Cornice in Maiolica lavorata a mano con decorazioni in bassorilievo per un design che si distingue per la sua asimmetria. Linee e geometria slanciate. Disponibile per più focolari, anche in versione bifacciale per una visione della fiamma da entrambi i lati.**

**EN** Hand-crafted majolica frame with bas-relief decorations, for a design that stands out for its asymmetrical visual impact. Slender lines and forms. Compatible with multiple firebox versions, also double-face version, for viewing the flame from both sides.

**DE** Einfassung aus handgearbeiteter Majolika mit Basrelief-Dekors und asymmetrischem Design. Verjüngte Linien und Geometrie. Für mehrere Feuerräume erhältlich, auch als zweiseitige Version für die Sicht auf die Flammen von beiden Seiten.

**FR** Cadre en faïence façonnée à la main avec décors sculptés en bas-relief, pour un design qui se distingue par sa forme asymétrique. Lignes et géométrie élancées. Disponible pour plusieurs foyers, ainsi qu'en version double face pour pouvoir admirer la flamme des deux côtés.

**ES** Marco de mayólica trabajada a mano con decoraciones en bajorrelieve para un diseño que se distingue por su asimetría. Líneas y formas esbeltas. Disponible para varios hogares, también en versión de doble cara para una visión de la llama desde los dos lados.



## COLORI - COLOURS

Bianco Antico  
Bruno Rame  
Grigio Cerato



→ Colori - Colours P.19

→ Focolari compatibili - Compatible fireboxes P.243



# BREMA

**Cornice ad incasso in Maiolica fatta a mano, realizzata in un unico pezzo con decorazioni in bassorilievo e profilo in metallo verniciato nero per la base, disponibili optional moduli da metro. Disponibile anche in versione bifacciale per una visione della fiamma da entrambi i lati.**

**EN** A built-in hand-crafted majolica frame, a single-piece element featuring bas-relief decorations and a black coated metal profile for the base; optional modules are available by the metre. Also available in the double-face version for viewing the flame from both sides.

**DE** Einbau-Einfassung aus handgefertigter Majolika, in einem Stück hergestellt, mit Basrelief-Dekors und Profil aus schwarz lackiertem Metall für den Sockel, Meter-Moduln optional erhältlich. Auch als zweiseitige Version für die Sicht auf die Flammen von beiden Seiten erhältlich.

**FR** Cadre encastré en faïence façonnée à la main, réalisé d'un seul tenant avec des décors sculptés en bas-relief et un profil en métal peint de couleur noire pour la base. Modules d'un mètre disponibles en option. Modèle également disponible en version double face pour assurer une vision de la flamme des deux côtés.

**ES** Marco empotrado de mayólica realizado a mano en una única pieza con decoraciones en bajorrelieve y perfil de metal barnizado de negro para la base, con módulos opcionales disponibles a partir de un metro. Disponible también en versión de doble cara para una visión de la llama desde los dos lados.



## COLORI - COLOURS

Bianco Grigio  
Bruno Rame  
Giallo Acceso  
Grigio Cerato  
Rosso Lava



→ Colori - Colours P.19

→ Focolari compatibili - Compatible fireboxes P.240



# LUBECCA

**Cornice in Maiolica lavorata a mano, realizzata con sapiente manifattura in un unico pezzo impreziosito da decorazioni in bassorilievo. Ampia la gamma di colori tra cui scegliere. Disponibile anche in versione bifacciale per una visione della fiamma da entrambi i lati.**

**EN** Hand-crafted majolica frame, a single piece stemming from skilled workmanship and enriched by bas-relief decorations. Extensive assortment of colours. Also available in the double-face version, for viewing the flame from both sides.

**DE** Einfassung aus handgearbeiteter Majolika, sorgfältig in einem einzigen Stück hergestellt und veredelt durch Basrelief-Dekors. Große Farbauswahl. Auch als zweiseitige Version für die Sicht auf die Flammen von beiden Seiten erhältlich.

**FR** Cadre de très belle facture en faïence façonnée à la main, savamment réalisé d'un seul tenant et agrémenté de décors sculptés en bas-relief. Large choix de couleurs. Disponible également dans une version double face permettant d'admirer la flamme des deux côtés.

**ES** Marco de mayólica trabajada a mano, fruto de una sabia manufactura, realizado a partir de una pieza única, embellecido con decoraciones en bajorrelieve. Amplia gama de colores para elegir. Disponible también en versión de doble cara para una visión de la llama desde los dos lados.



## COLORI - COLOURS

Bianco Grigio  
Bruno Rame  
Giallo Acceso  
Grigio Cerato  
Rosso Lava



→ Colori - Colours P.19

→ Focolari compatibili - Compatible fireboxes P.242





# DRESDA

**Rivestimento in Maiolica lavorata a mano, con decorazioni in bassorilievo. Il design è lineare, semplice nella sua essenzialità, sofisticato per le sue pregiate lavorazioni in bassorilievo. Il rivestimento Dresda accoglie numerosissimi focolari a legna anche in versione bifacciale, a pellet, ed anche in versione Thermo.**

**EN** Hand-crafted majolica surround with bas-relief decorations. The linear, clean design is enriched by refined bas-relief decorations. The Dresda surround is compatible with numerous wood-burning fireboxes, also double-faced, and pellet-burning models, also in the Thermo version.

**DE** Verkleidung aus handgefertigter Majolika mit Basrelief-Dekors. Das Design ist linear, simpel in seiner Schlichtheit, aber raffiniert durch seine edlen Basrelief-Arbeiten. Die Verkleidung Dresda nimmt zahlreiche Feuerräume für Holzfeuerung auf, auch in zweiseitiger Version, und für Pelletfeuerung, und auch in Thermo-Version.

**FR** Revêtement en faïence façonnée à la main, avec décors sculptés en bas-relief. Le design est linéaire, simple et essentiel, mais aussi sophistiqué grâce à ses prestigieuses sculptures en bas-relief. Le revêtement Dresda peut accueillir de très nombreux foyers à bois, même en version double face, à granulés et aussi en version thermo.

**ES** Revestimiento de mayólica trabajada a mano, con decoraciones en bajorrelieve. El diseño es lineal y esencial, con el toque de sofisticación que le confieren las elaboraciones de bajorrelieve. El revestimiento Dresda acoge incontables hogares de leña también en versión de doble cara, de pellets y en versión Thermo.



## COLORI - COLOURS

Bianco Grigio  
Bruno Rame  
Grigio Cerato  
Grigio Ferro  
Rosso Lava



→ Colori - Colours P.19

→ Focolari compatibili - Compatible fireboxes P.241



# ESSEN

**Rivestimento in pregiata Maiolica lavorata a mano, che sembra morbidamente avvolgere il focolare, lo racchiude e ne esalta lo spettacolo del fuoco.**

**Molto ampia la scelta dei focolari possibili, a legna e a pellet, anche nelle versioni Thermo. È disponibile anche una versione bifacciale per una visione della fiamma da entrambi i lati.**

**EN** The refined hand-crafted majolica surround delicately envelops the firebox and encloses it all around, enhancing the spectacle of the fire. Compatible with an extensive range of fireboxes, wood-burning or pellet-burning, also in the Thermo versions. A double-face version is also available, for viewing the flame from both sides.

**DE** Verkleidung aus edler, handgearbeiteter Majolika, die sich weich um den Feuerraum schmiegt, ihn umschließt und das Schauspiel des Feuers unterstreicht. Sehr große Auswahl an möglichen Feuerräumen, für Holz- und Pelletfeuerung, auch in Thermo-Versionen. Auch als zweiseitige Version erhältlich, für die Sicht auf das Feuer von beiden Seiten.

**FR** Revêtement en précieuse faïence façonnée à la main, qui semble envelopper le foyer en douceur et exalte le spectacle du feu. Le choix des foyers est très étendu : à bois et à granulés, mais aussi en version thermo. Ce revêtement est également disponible dans une version double face qui permet d'admirer la flamme des deux côtés.

**ES** Revestimiento en preciosa mayólica trabajada a mano, que parece envolver suavemente el hogar, encerrándolo y enaltecendo el espectáculo del fuego. Amplio repertorio de hogares posibles, de leña o pellets, también en las versiones Thermo. Disponible además una versión de doble cara para una visión de la llama desde los dos lados.



## COLORI - COLOURS

Bianco Grigio  
Blu Verdemare  
Bruno Rame  
Giallo Acceso  
Rosso Lava



→ Colori - Colours P.19

→ Focolari compatibili - Compatible fireboxes P.241



# COLONIA

**Rivestimento in Maiolica lavorata a mano, impreziosita dalla presenza di decori in bassorilievo. Il telaio in acciaio, può essere verniciato in nero o grigio. Disponibile per una veramente ampia gamma di focolari a legna, anche in versione Thermo, e pellet, anche in versione thermo.**

**EN** Hand-crafted majolica surround, enriched by bas-relief decorations. The steel frame can be coated black or grey. Compatible with an extensive range of wood-burning and pellet-burning fireboxes, also in the Thermo version.

**DE** Verkleidung aus handgearbeiteter Majolika, veredelt durch Basrelief-Dekors. Der Stahl-Rahmen kann schwarz oder grau lackiert werden. Erhältlich für eine wirklich große Auswahl von Feuerräumen für Holzfeuerung, auch als Thermo-Version, und für Pelletfeuerung, auch als Thermo-Version.

**FR** Revêtement en faïence façonnée à la main, enrichie par la présence de décors sculptés en bas-relief. Le cadre est en acier et peut être peint en noir ou en gris. Revêtement disponible pour une très large gamme de foyers à bois et à granulés, également en version thermo.

**ES** Revestimiento de mayólica trabajada a mano, embellecida por la presencia de decoraciones en bajorrelieve. El bastidor de acero puede pintarse de negro o de gris. Disponible para una gama sumamente amplia de hogares de leña o de pellets, también en versión Thermo.



## COLORI - COLOURS

Bianco Grigio  
Bruno Rame  
Giallo Acceso  
Grigio Cerato  
Rosso Lava

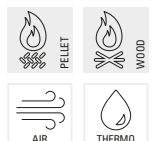

→ Colori - Colours P.19

→ Focolari compatibili - Compatible fireboxes P.240



# NEW ORLEANS

**Cornice in Maiolica lavorata a mano realizzata in un unico pregiato elemento di maestrale realizzazione. La sua apparente semplicità richiede notevole esperienza e maestria artigiana. Tra i focolari a legna disponibili è possibile scegliere anche la versione bifacciale per una visione della fiamma da entrambi i lati.**

**EN** A hand-crafted majolica frame made from a single refined piece revealing supreme workmanship. Its apparent simplicity demands considerable artisan expertise and workmanship. Among the wood-burning fireboxes, it is possible to choose the double-face version for viewing the flame from both sides.

**DE** Einfassung aus handgearbeiteter Majolika, meisterhaft ausgeführt in einem einzigen edlen Element. Seine scheinbare Einfachheit erfordert beträchtliche handwerkliche Erfahrung und Meisterschaft. Unter den erhältlichen Feuerstätten für Holzfeuerung kann auch die zweiseitige Version für die Sicht auf die Flammen von beiden Seiten gewählt werden.

**FR** Cadre en faïence façonnée à la main, magistralement réalisé d'une seul tenant. Son apparente simplicité nécessite une expérience considérable ainsi qu'une grande maîtrise artisanale. Parmi les foyers à bois disponibles, il est également possible de choisir une version double face qui permet d'admirer la flamme des deux côtés.

**ES** Marco de mayólica trabajada a mano, realizado en un único y preciado elemento elaborado con sabiduría. Su aparente simplicidad requiere notable experiencia y maestría artesanal. Entre los hogares de leña disponibles se puede elegir también la versión de doble cara para una visión de la llama desde los dos lados.



#### COLORI - COLOURS

Grigio Ferro  
Moka  
Neve



→ Colori - Colours P.19

→ Focolari compatibili - Compatible fireboxes P.242





# COLORADO

**Rivestimento in Maiolica lavorata a mano con particolari e profili laterali in acciaio verniciato nero. In base alle necessità di ambiente è possibile scegliere le versioni ad angolo destro o sinistro. Disponibile anche in versione bifacciale, che offre una spettacolare visione della fiamma.**

**EN** Hand-crafted majolica surround featuring black-coated steel side profiles. Depending on the room's requirements, it is possible to choose either the right-hand or left-hand corner version. Also available in the double-face version, which offers a spectacular view of the flame.

**DE** Verkleidung aus handgearbeiteter Majolika mit Details und seitlichen Profilen aus schwarz lackiertem Stahl. Je nach räumlichen Bedürfnissen kann eine Version mit rechter oder linker Ecke gewählt werden. Auch erhältlich in zweiseitiger Version, die eine spektakuläre Sicht auf die Flammen bietet.

**FR** Revêtement en faïence façonnée à la main avec détails et profils latéraux en acier peint noir. En fonction des nécessités de la pièce, il est possible de choisir la version avec angle à droite ou à gauche. Modèle également disponible en version double face, qui offre une vision spectaculaire de la flamme.

**ES** Revestimiento de mayólica trabajada a mano con detalles y perfiles laterales de acero pintado negro. Según las exigencias del ambiente se puede elegir la versión en esquina derecha o izquierda. Disponible también en la versión de doble cara, que ofrece una vista espectacular de la llama.



## COLORI - COLOURS

Grigio Ferro  
Moka  
Neve



→ Colori - Colours P.19

→ Focolari compatibili - Compatible fireboxes P.241



# CALAIS

**Rivestimento realizzato in Maiolica lavorata a mano con la particolarità di avere i profili laterali in acciaio pallinato. Ogni particolare è ricercato e conferisce unicità e pregio a questo caminetto. Sono disponibili più modelli di focolari per la realizzazione di suggestivi caminetti.**

**EN** Hand-crafted majolica surround with blasted steel side profiles. Each finely worked detail add a unique and refined touch to this fireplace. Multiple firebox versions are available to create fascinating fireplaces.

**DE** Verkleidung aus handgearbeiteter Majolika mit der Besonderheit, dass die Seitenprofile aus kugelgestrahltem Stahl sind. Die erlesenen Details verleihen diesem Kamin Einzigartigkeit und besonderen Wert. Zur Realisierung stimmungsvoller Kamine sind mehrere Feuerraum-Modelle erhältlich.

**FR** Revêtement réalisé en faïence façonnée à la main, dont la particularité réside dans ses profils latéraux en acier grenailé. Chaque détail est recherché et confère à cette cheminée un aspect unique et précieux. Plusieurs modèles de foyers sont disponibles, pour la réalisation de cheminées évocatrices.

**ES** Revestimiento realizado en mayólica trabajada a mano caracterizado por perfiles laterales de acero granallado. Cada detalle, con su refinamiento, confiere valor y un carácter único a esta chimenea. Varios modelos de hogar disponibles para la realización de chimeneas encantadoras.



## COLORI - COLOURS

Grigio Ferro  
Moka  
Neve



→ Colori - Colours P.19

→ Focolari compatibili - Compatible fireboxes P.240



# SUN

**L'unicità di un oggetto che nell'arte della lavorazione pone il suo sapersi distinguere. In foto Maiolica finitura Viola Alba impreziosita da dettagli pennellati in cristallina tono su tono su pannello laterale. Disponibile, oltre che nei colori della famiglia Basic anche con le pregiate finiture delle linee Elegance e Luxury.**

**EN** The uniqueness of an object that stands out for its fine workmanship. The picture shows the majolica with Viola Alba finish, enriched by brushed tone-on-tone crystalline details on the side panel. Available in the colours of the Basic range and also with the refined finishes of the Elegance and Luxury ranges.

**DE** Die Einzigartigkeit eines Objekts, das sich durch die Kunst bei der Bearbeitung auszuzeichnen weiß. Auf dem Foto Majolika mit Finish Viola Alba, veredelt durch Pinselstrichdetails aus Transparentglasur Ton in Ton am Seitenpaneel. In den Farben der Basic-Familie sowie mit den edlen Oberflächenfinishes der Linien Elegance und Luxury erhältlich.

**FR** Un objet unique qui démontre sa capacité à sortir du lot grâce à sa superbe réalisation. En photo, version en faïence finition Viola Alba ornée sur le panneau latéral de détails en émail ton sur ton réalisés au pinceau. Outre les couleurs de la famille Basic, ce modèle existe aussi dans les finitions précieuses des lignes Elegance et Luxury.

**ES** La exclusividad de un objeto que sabe hacerse reconocer en el arte de la elaboración. En la foto, mayólica con acabado Viola Alba con detalles pincelados de esmalte vítreo tono sobre tono en el panel lateral. Disponible en los colores de la familia Basic y con los preciados acabados de las líneas Elegance y Luxury.



#### COLORI - COLOURS

Linea Basic  
Linea Elegance  
Linea Luxury

→ Dettagli - Details P.179



→ Colori - Colours P.19, P.21

→ Focolari compatibili - Compatible fireboxes P.243



# ACADEMY

**Rivestimento in Maiolica fatto a mano con base, frontalino e profili in acciaio pallinato. Design essenziale dalle linee moderne dal tratto deciso. Disponibile per numerosi focolari a legna anche in versione Thermo. Alla particolarità di questo rivestimento è possibile abbinare anche un focolare bifacciale.**

**EN** Hand-made majolica surround with blasted steel profiles, base and front element. Sober design featuring modern, sharp lines. Compatible with numerous wood-burning fireboxes, even in the Thermo version. This special surround can also be combined with a double-face firebox.

**DE** Verkleidung aus handgefertigter Majolika mit Sockel, Frontblende und Profilen aus kugelgestrahltem Stahl. Minimalistisches Design mit modernen Linien und markanten Zügen. Für zahlreiche Feuerräume für Holzfeuerung auch in Thermo-Version erhältlich. Diese besondere Verkleidung kann auch mit einem zweiseitigen Feuerraum kombiniert werden.

**FR** Revêtement en faïence réalisée à la main, avec base, bande de façade et profils en acier grenailé. Design essentiel aux lignes modernes et au trait décidé. Disponible pour de nombreux foyers à bois, également en version thermo. À ce revêtement si particulier, il est aussi possible d'associer un foyer à double face.

**ES** Revestimiento de mayólica hecho a mano con base, frente y perfiles de acero granallado. Diseño esencial con líneas modernas con un trazado resuelto. Disponible para numerosos hogares de leña también en versión Thermo. A la particularidad de este revestimiento se puede asociar también un hogar de doble cara.



## COLORI - COLOURS

Grigio Ferro  
Moka  
Neve  
Ollare



WOOD



AIR



THERMO

→ Colori - Colours P.19

→ Focolari compatibili - Compatible fireboxes P.240





# FORUM

**Rivestimento in Maiolica lavorata a mano di pregiata manifattura. Il design con un frontale dalle linee essenziali mette in evidenza la forma concava che gli dà forza e si staglia maggiormente dalla parete. Disponibile, oltre che nei colori della famiglia Basic anche con le pregiate finiture delle linee Elegance e Luxury. Anche bifacciale.**

**EN** Finely crafted hand-made majolica surround. With its clean lines, the design enhances the concave surfaces which emerge vigorously from the wall. Available in the colours of the Basic range and also with the refined finishes of the Elegance and Luxury ranges. Two-faced version also available.

**DE** Verkleidung aus hochwertiger, handgearbeiteter Majolika. Das Design mit einer Front mit klaren Linien hebt die konkave Form hervor, die ihm Kraft gibt und sich stärker von der Wand abhebt. In den Farben der Basic-Familie sowie mit den edlen Oberflächenfinishes der Linien Elegance und Luxury erhältlich. Auch zweiseitig.

**FR** Revêtement en faïence façonnée à la main de très belle facture. Avec une façade aux lignes essentielles, le design tire sa force de sa forme concave qui lui permet de mieux se détacher du mur. Outre les couleurs de la famille Basic, ce modèle est aussi disponible dans les finitions précieuses des lignes Elegance et Luxury. Version double face possible.

**ES** Revestimiento de mayólica trabajada a mano de preciada manufactura. El diseño con frente de líneas esenciales resalta la forma cóncava que le da fuerza y se destaca en mayor medida de la pared. Disponible en los colores de la familia Basic y con los preciosos acabados de las líneas Elegance y Luxury. También en versión de doble cara.



#### COLORI - COLOURS

Linea Basic  
Linea Elegance  
Linea Luxury

→ Dettagli - Details P.176



→ Colori - Colours P.19, P.21

→ Focolari compatibili - Compatible fireboxes P.241



# GALLERY

**Rivestimento in Maiolica lavorata a mano impreziosita da sfumature e dettagli in cristallina tono su tono. Disponibile anche in versione bifacciale per una visione della fiamma da entrambi i lati. Disponibile, oltre che nei colori della famiglia Basic anche con le pregiate finiture delle linee Elegance e Luxury.**

**EN** Hand-crafted majolica surround enriched by tone-on-tone crystalline details and nuances. Double-face version also available, for viewing the flame from both sides. Available in the colours of the Basic range and also with the refined finishes of the Elegance and Luxury ranges.

**DE** Verkleidung aus handgearbeiteter Majolika, veredelt durch Schattierungen und Details aus Transparentglasur Ton in Ton. Auch erhältlich als zweiseitige Version für die Sicht auf die Flammen von beiden Seiten. In den Farben der Basic-Familie sowie mit den edlen Oberflächenfinishes der Linien Elegance und Luxury erhältlich.

**FR** Revêtement en faïence façonnée à la main et enrichie de nuances et de détails en émail ton sur ton. Disponible également en version double face permettant d'admirer la flamme des deux côtés. Outre les couleurs de la famille Basic, ce modèle est aussi disponible dans les finitions précieuses des lignes Elegance et Luxury.

**ES** Revestimiento de mayólica trabajada a mano, embellecida por matices y detalles de esmalte vítreo tono sobre tono. Disponible también en versión de doble cara para una visión de la llama desde los dos lados. Disponible en los colores de la familia Basic y con los preciados acabados de las líneas Elegance y Luxury.



## COLORI - COLOURS

Linea Basic  
Linea Elegance  
Linea Luxury

→ Dettagli - Details P.177



→ Colori - Colours P.19, P.21

→ Focolari compatibili - Compatible fireboxes P.242



# VISION

**Caminetto realizzato con pannelli in Maiolica lavorata a mano di grandi dimensioni, di grande impatto e con importanti lavorazioni di decoro. Disponibile per più focolari anche nella versione bifacciale per una visione della fiamma da entrambi i lati.**

**EN** A fireplace made with large-size hand-crafted majolica panels, offering a striking visual impact and featuring imposing decorative details. Compatible with multiple firebox models, also in the double-face version, for viewing the flame from both sides.

**DE** Sehr eindrucksvoller Kamin mit großen Platten aus handgearbeiteter Majolika und umfangreichen Dekorarbeiten. Für mehrere Feuerräume erhältlich, auch als zweiseitige Version für die Sicht auf die Flammen von beiden Seiten.

**FR** Cheminée réalisée à partir de panneaux en faïence façonnée à la main de grandes dimensions, offrant un fort impact visuel et ornée de nombreux décors. Disponible pour plusieurs foyers, ainsi qu'en version double face pour pouvoir admirer la flamme des deux côtés.

**ES** Chimenea realizada con paneles de mayólica trabajada a mano de grandes dimensiones, de gran impacto y con importantes elaboraciones de decoración. Disponible para varios hogares también en la versión de doble cara para una visión de la llama desde los dos lados.



## COLORI - COLOURS

Grigio Ferro  
Moka  
Neve  
Ollare

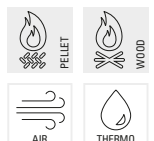

→ Colori - Colours P.19

→ Focolari compatibili - Compatible fireboxes P.243



# VOYAGER

**Il carattere di un caminetto che sa distinguersi, particolare e ricercato. In foto Maiolica finitura Verde Pennellato, con decoro in cristallina tono su tono su pannello laterale. Disponibile, oltre che nei colori della famiglia Basic anche con le pregiate finiture delle linee Elegance e Luxury. Disponibile anche con focolare a legna bifacciale.**

**EN** The character of a distinctive fireplace with an original and sophisticated look. In the picture, majolica with Verde Pennellato finish and crystalline tone-on-tone decoration on the side panel. Available in the colours of the Basic range and also with the refined finishes of the Elegance and Luxury ranges. Also available with double-face firebox.

**DE** Der Charakter eines herausragenden Kamins, besonders und erlesen. Auf dem Foto Majolika mit Finish Verde Pennellato, mit Dekor aus Transparentglasur Ton in Ton am Seitenpaneel. In den Farben der Basic-Familie sowie mit den edlen Oberflächenfinishes der Linien Elegance und Luxury erhältlich, auch mit zweiseitigem Feuerraum für Holzfeuerung.

**FR** Une cheminée de caractère, particulière et recherchée, qui sait sortir du lot. En photo, version en faïence Verde Pennellato, avec décor en émail ton sur ton sur le panneau latéral. Disponible dans les couleurs de la famille Basic et dans les finitions des lignes Elegance et Luxury. Disponible également avec foyer à bois double face.

**ES** El carácter de una chimenea singular y refinada que sabe hacerse notar. En la foto, mayólica con acabado Verde Pennellato con decoración de esmalte vítreo tono sobre tono en el panel lateral. Disponible en los colores de la familia Basic y con los preciados acabados de las líneas Elegance y Luxury. Disponible también con hogar de leña doble cara.



## COLORI - COLOURS

Linea Basic  
Linea Elegance  
Linea Luxury

→ Dettagli - Details P.179

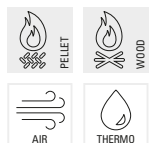

→ Colori - Colours P.19, P.21

→ Focolari compatibili - Compatible fireboxes P.243





# CLASS

**Rivestimento in Maiolica lavorata a mano in modo artigianale caratterizzato da una dolce curvatura della parte frontale. Base, frontalino e profili in acciaio pallinato. Disponibile per l'inserimento di numerosi focolari a legna.**

**EN** Hand-crafted majolica surround characterised by a gently curving front profile. Blasted steel base, front element and profiles. Compatible with various wood-burning fireboxes.

**DE** Verkleidung aus kunsthandwerklich gearbeiteter Majolika mit sanfter Krümmung der Frontseite. Sockel, Frontblende und Profile aus kugelgestrahltem Stahl. Erhältlich für den Einbau zahlreicher Heizeinsätze für Holzfeuerung.

**FR** Revêtement en faïence façonnée à la main de manière artisanale, caractérisé par une courbe douce sur la partie avant. Base, façade et profils en acier grenailé. Ce modèle permet l'insertion de nombreux monoblocs à bois.

**ES** Revestimiento de mayólica trabajada a mano artesanalmente, caracterizado por un suave curvado de la parte frontal. Base, frente y perfiles de acero granallado. Disponible para la introducción de numerosos monobloques de leña.



#### COLORI - COLOURS

Grigio Ferro  
Moka  
Neve



→ Colori - Colours P.19

→ Focolari compatibili - Compatible fireboxes P.240



# ZEUS

**Rivestimento in Maiolica lavorata a mano con tecnica e sapienza. In foto la finitura Oro Decorato impreziosito da particolari foglia Oro. Disponibile, oltre che nei colori della famiglia Basic anche con le pregiate finiture delle linee Elegance e Luxury. Tra i focolari disponibili c'è anche una versione a legna bifacciale.**

**EN** Hand-crafted majolica surround revealing skilled, high-quality workmanship. The picture shows the Oro Decorato finish enriched by gold-leaf details. Available in the colours of the Basic range and also with the refined finishes of the Elegance and Luxury ranges. The firebox models also include a wood-burning double-face version.

**DE** Verkleidung aus meisterhaft handgearbeiteter Majolika. Auf dem Foto das Oberflächenfinish Oro Decorato, veredelt mit Blattgolddetails. In den Farben der Basic-Familie sowie mit den edlen Oberflächenfinishs der Linien Elegance und Luxury erhältlich. Unter den erhältlichen Feuerräumen gibt es auch eine zweiseitige Version für Holzfeuerung.

**FR** Revêtement en faïence façonnée à la main avec technique et savoir-faire. En photo, la finition Oro Decorato agrémentée de détails en feuille d'Or. Disponible dans les couleurs de la famille Basic et dans les finitions des lignes Elegance et Luxury. Parmi les foyers disponibles, il existe également une version à bois double face.

**ES** Revestimiento de mayólica trabajada a mano con técnica y sabiduría. En la foto, el acabado Oro Decorado, embellecido con detalles de hoja de oro. Disponible en los colores de la familia Basic y con los preciados acabados de las líneas Elegance y Luxury. Entre los hogares disponibles hay también una versión de leña de doble cara.



## COLORI - COLOURS

Linea Basic  
Linea Elegance  
Linea Luxury

→ Dettagli - Details P.179



→ Colori - Colours P.19, P.21

→ Focolari compatibili - Compatible fireboxes P.243



# CAPITAL

**Rivestimento in Maiolica lavorata e decorata a mano impreziosito da decori in cristallina Argento.**

**Disponibile, oltre che nei colori della famiglia Basic anche con le pregiate finiture delle linee Elegance e Luxury, esempio della più elevata maestria della lavorazione della Maiolica esaltata dalla preziosità dei decori.**

**EN** Surround made of majolica crafted and decorated by hand, enriched by silver crystalline decorations. Available in the Basic colours and also in the refined finishes of the Elegance and Luxury ranges, the ultimate in majolica craftsmanship, enhanced by the refined decorations.

**DE** Verkleidung aus handgearbeiteter und von Hand dekoriertes Majolika, veredelt durch Dekors in Argento Transparentglasur. In den Farben der Basic-Familie sowie mit den edlen Oberflächenfinishes der Linien Elegance und Luxury erhältlich, Beispiel für meisterhafte Majolika-Arbeiten, die durch wertvolle Dekors betont werden.

**FR** Revêtement en faïence façonnée à la main et agrémenté de décors en émail Argento. Outre les couleurs de la famille Basic, ce modèle est aussi disponible dans les finitions précieuses des lignes Elegance et Luxury. Un exemple de maîtrise parfaite du travail de la faïence, exaltée par l'aspect précieux des décors.

**ES** Revestimiento de mayólica trabajada y decorada a mano, embellecido con decoraciones de esmalte vítreo Argento. Disponible en los colores de la familia Basic y con los preciados acabados de las líneas Elegance y Luxury, ejemplo de la más alta maestría en la realización de la mayólica, enaltecida por el precioso decorado.



## COLORI - COLOURS

Linea Basic  
Linea Elegance  
Linea Luxury

→ Dettagli - Details P.176



→ Colori - Colours P.19, P.21

→ Focolari compatibili - Compatible fireboxes P.240



# SAN DIEGO

**Importante e ricercato caminetto con rivestimento realizzato in grandi pannelli in Maiolica lavorata a mano con dettagli in cristallina. Disponibile, oltre che nei colori della famiglia Basic anche con le pregiate finiture delle linee Elegance e Luxury. Disponibile anche in versione bifacciale.**

**EN** An imposing and sophisticated fireplace made with large hand-crafted majolica surround panels, featuring crystalline details. Available in the colours of the Basic range and also with the refined finishes of the Elegance and Luxury ranges. Double-face version also available.

**DE** Eindrucksvoller und erlesener Kamin mit Verkleidung aus großen, handwerklich gearbeiteten Majolika-Platten mit Details aus Transparentglasur. In den Farben der Basic-Familie sowie mit den edlen Oberflächenfinishes der Linien Elegance und Luxury erhältlich. Auch als zweiseitige Version erhältlich.

**FR** Cheminée imposante et recherchée avec revêtement constitué de grands panneaux en faïence façonnée à la main, avec détails en émail. Outre les couleurs de la famille Basic, ce modèle est aussi disponible dans les finitions précieuses des lignes Elegance et Luxury. Également disponible en version double face.

**ES** Importante y refinada chimenea con revestimiento realizado en grandes paneles de mayólica trabajada a mano con detalles de esmalte vítreo. Disponible en los colores de la familia Basic y con los preciados acabados de las líneas Elegance y Luxury. Disponible también en versión de doble cara.



#### COLORI - COLOURS

Linea Basic  
Linea Elegance  
Linea Luxury

→ Dettagli - Details P.178



→ Colori - Colours P.19, P.21

→ Focolari compatibili - Compatible fireboxes P.243





# CHESTER

**Originale rivestimento in Maiolica di grande superficie lavorata a mano con sviluppo orizzontale. Il pannello frontale, caratterizzato per essere senza giunzioni, e la panca sono disponibili in un'ampia gamma di colori. Telaio in acciaio verniciato nero.**

**EN** Features an original, large-size hand-crafted majolica surround extending horizontally. The front panel – characterised by its joint-free assembly – and the bench are available in a wide range of colours. Black coated steel frame.

**DE** Originelle Verkleidung aus Majolika mit großer, handgearbeiteter Oberfläche in horizontaler Ausrichtung. Die Frontplatte, die sich durch ihre Fugenlosigkeit auszeichnet, und die Sitzbank sind in einer großen Auswahl von Farben erhältlich. Rahmen aus schwarz lackiertem Stahl.

**FR** Revêtement original en faïence de grande surface façonnée à la main et à développement horizontal. La façade, caractérisée par l'absence de raccords, et la banquette sont disponibles dans une large gamme de couleurs. Cadre en acier peint noir.

**ES** Original revestimiento de mayólica de amplia superficie trabajada a mano con disposición horizontal. El panel frontal, caracterizado por no presentar juntas, y el banco, están disponibles en una amplia gama de colores. Bastidor de acero pintado negro.



## COLORI - COLOURS

Ardesia	Tabacco
Bianco Antico	Terra Cotta
Bianco Grigio	Tortora
Kaki	
Mattone	
Sahara	
Senape	



→ Colori - Colours P.19

→ Focolari compatibili - Compatible fireboxes P.240



# CAMBRIDGE

**Rivestimento a sviluppo orizzontale con pannello frontale e base in Maiolica, entrambi ricavati da un unico elemento di notevoli dimensioni che permette di avere soluzioni esteticamente uniche senza giunzioni, disponibile in un'ampia gamma di colori. Telaio in acciaio verniciato nero. Disponibile per un'ampia gamma di focolari.**

**EN** Horizontally oriented surround with majolica front panel and base, both derived from a single large element that allows for creating aesthetically unique solutions without joints, available in a extensive range of colours. Black coated steel frame. Compatible with a wide range of fireboxes.

**DE** Horizontal ausgerichtete Verkleidung mit Frontplatte und Sockel aus Majolika, beide aus einem einzigen großen Element, was ästhetisch einzigartige, fugenlose Lösungen ermöglicht. In großer Farbauswahl erhältlich. Rahmen aus schwarz lackiertem Stahl. Für zahlreiche Feuerräume erhältlich.

**FR** Revêtement à développement horizontal avec façade et base en faïence, tous deux créés à partir d'un unique élément de dimensions importantes qui permet d'obtenir des solutions sans raccords à l'esthétique unique, disponible dans une vaste gamme de couleurs. Cadre en acier peint noir. Disponible pour une large gamme de foyers.

**ES** Revestimiento dispuesto en horizontal con panel frontal y base de mayólica, elaborados a partir de un único elemento de considerables dimensiones que permite obtener soluciones estéticas únicas sin juntas, disponibles en una amplia gama de colores. Bastidor de acero pintado negro. Disponible para un vasto repertorio de hogares.



#### COLORI - COLOURS

Ardesia	Tabacco
Bianco Antico	Terra Cotta
Bianco Grigio	Tortora
Kaki	
Mattone	
Sahara	
Senape	



→ Colori - Couleurs P.19

→ Focolari compatibili - Compatible fireboxes P.240



# SHEFFIELD

**Caminetto minimal con una caratterizzante base in Maiolica realizzata a mano, disponibile in un'ampia gamma di colori. Telaio e rialzo in acciaio verniciato nero. Le notevoli dimensioni del focolare rendono la soluzione estetica unica ed esclusiva e permettono una spettacolare visione della fiamma.**

**EN** A minimalist fireplace with a distinctive hand-crafted majolica base, available in a wide range of colours. Black-coated steel frame and riser. The considerable dimensions of the firebox make the aesthetic solution unique and exclusive, besides affording a spectacular view of the flame.

**DE** Minimalistischer Kamin mit charakteristischem Sockel aus handgefertigter Majolika, in großer Farbauswahl erhältlich. Rahmen und Aufsatz aus schwarz lackiertem Stahl. Die beträchtlichen Abmessungen des Heizeinsatzes machen diese Lösung ästhetisch einzigartig und exklusiv und bieten eine spektakuläre Sicht auf die Flammen.

**FR** Cheminée minimaliste dotée d'une base caractéristique en faïence façonnée à la main, disponible dans une large gamme de couleurs. Cadre et rehausse en acier peint noir. Les dimensions considérables de ce monobloc en font une solution esthétique unique et exclusive et permettent une vision spectaculaire de la flamme.

**ES** Chimenea minimalista con una peculiar base de mayólica realizada a mano, disponible en una amplia gama de colores. Bastidor y realce de acero pintado negro. Las vastas dimensiones del monobloque hacen del producto una solución estética única y exclusiva y ofrecen una vista espectacular de la llama.



## COLORI - COLOURS

Ardesia	Tabacco
Bianco Antico	Terra Cotta
Bianco Grigio	Tortora
Kaki	
Mattone	
Sahara	
Senape	



→ Colori - Colours P.19

→ Focolari compatibili - Compatible fireboxes P.243



# SURFACE

**Importante caminetto con rivestimento realizzato in grandi pannelli di Maiolica lavorata a mano, di grande ricercatezza con decori laterali impreziositi da dettagli in cristallina. Disponibile, oltre che nei colori della famiglia Basic anche con le pregiate finiture delle linee Elegance e Luxury. Anche bifacciale.**

**EN** An imposing fireplace made with large hand-crafted majolica surround panels, highly sophisticated, with side decorations enriched by crystalline details. Available in the colours of the Basic range and also with the refined finishes of the Elegance and Luxury ranges. Double-face version also available.

**DE** Eindrucksvoller Kamin mit Verkleidung aus großen, handgearbeiteten Majolika-Platten in erlesener Qualität mit seitlichen Dekors, die durch Details aus Transparentglasur veredelt sind. In den Farben der Basic-Familie sowie mit den edlen Oberflächenfinishs der Linien Elegance und Luxury erhältlich. Auch zweiseitig.

**FR** Imposante cheminée avec revêtement constitué de grands panneaux très raffinés réalisés en faïence façonnée à la main et ornés de détails en émail. Outre les couleurs de la famille Basic, ce modèle est aussi disponible dans les finitions précieuses des lignes Elegance et Luxury. Également disponible en version double face.

**ES** Importante chimenea con revestimiento realizado en grandes paneles de mayólica trabajada a mano, con gran refinamiento y decoraciones laterales embellecidas con detalles de esmalte vítreo. Disponible en los colores de la familia Basic y con los preciosos acabados de las líneas Elegance y Luxury. También en doble cara.



## COLORI - COLOURS

Linea Basic  
Linea Elegance  
Linea Luxury

→ Dettagli - Details P.179



→ Colori - Colours P.19, P.21

→ Focolari compatibili - Compatible fireboxes P.243





# FOX

**Per un caminetto di importante impatto estetico, questo rivestimento, realizzato con grandi pannelli di Maiolica lavorata a mano e minuziosamente decorata con bassorilievi rappresenta una pregevole soluzione. In foto la finitura Platino, Damascato. Base, frontalino e profili in acciaio pallinato.**

**EN** For a fireplace offering such a striking visual impact, the surround – consisting of large hand-crafted majolica panels and finely worked bas-relief decorations – represents a refined solution. The picture shows the Platino finish with Damascato decoration. Blasted steel base, front element and profiles.

**DE** Für einen Kamin mit sehr markantem ästhetischen Auftritt stellt diese Verkleidung mit großen Platten aus handgearbeiteter und minuziös mit Basreliefs dekorierte Majolika eine hochklassige Lösung dar. Auf dem Foto das Finish Platino, Damascato. Sockel, Frontblende und Profile aus kugelgestrahltem Stahl.

**FR** Pour une cheminée à fort impact esthétique, ce revêtement réalisé avec de grands panneaux de faïence façonnée à la main et minutieusement décorée avec des sculptures en bas-relief représente une solution précieuse. En photo, la finition Platino, décor Damascato. Base, bande de façade et profils en acier grenailé.

**ES** Para una chimenea de alto impacto estético, este revestimiento, hecho con grandes paneles de mayólica trabajada a mano y minuciosamente decorada con bajorrelieves, representa una solución de gran valor. En la foto, el acabado Platino Damascato. Base, frente y perfiles de acero granallado.



#### COLORI - COLOURS

Linea Basic  
Linea Elegance  
Linea Luxury

→ Dettagli - Details P.177



→ Colori - Colours P.19, P.21

→ Focolari compatibili - Compatible fireboxes P.241



# MOOD

**Caminetto dalle grandi dimensioni con rivestimento in Maiolica lavorata a mano impreziosito da dettagli pennellati in cristallina tono su tono. Disponibile, oltre che nei colori della famiglia Basic anche con le pregiate finiture delle linee Elegance e Luxury. Anche bifacciale.**

**EN** A large-size fireplace with hand-crafted majolica surround, enriched by tone-on-tone crystalline striped details. Blasted steel riser and profiles. Available in the colours of the Basic range and also with the refined finishes of the Elegance and Luxury ranges. Double-face version also available.

**DE** Großer Kamin mit Verkleidung aus handgearbeiteter Majolika, veredelt durch Pinselstrichdetails aus Transparentglasur Ton in Ton. In den Farben der Basic-Familie sowie mit den edlen Oberflächenfinishes der Linien Elegance und Luxury erhältlich. Auch zweiseitig.

**FR** Cheminée de grandes dimensions avec revêtement en faïence façonnée à la main agrémenté de détails en émail ton sur ton réalisés au pinceau. Outre les couleurs de la famille Basic, ce modèle est aussi disponible dans les finitions précieuses des lignes Elegance et Luxury. Également disponible en version double face.

**ES** Chimenea de grandes dimensiones con revestimiento de mayólica trabajada a mano, embellecida con detalles pincelados en esmalte vítreo tono sobre tono. Disponible en los colores de la familia Basic y con los preciados acabados de las líneas Elegance y Luxury. También en doble cara.

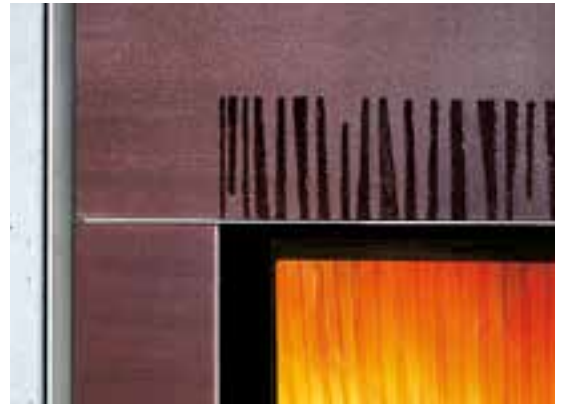

#### COLORI - COLOURS

Linea Basic  
Linea Elegance  
Linea Luxury

→ Dettagli - Details P.177



→ Colori - Colours P.19, P.21

→ Focolari compatibili - Compatible fireboxes P.242



# CRUISE

**Per un caminetto di importante impatto estetico, questo rivestimento, realizzato con grandi pannelli di Maiolica lavorata a mano e minuziosamente decorata con bassorilievi rappresenta una pregevole soluzione. In foto la finitura Oro, con decoro oro Damascato. Base, frontalino e profili in acciaio pallinato.**

**EN** For a fireplace offering such a striking visual impact, the surround – consisting of large hand-crafted majolica panels and finely worked bas-relief decorations – represents a refined solution. The picture shows the Oro finish with Oro Damascato decoration. Blasted steel base, front element and profiles.

**DE** Für einen Kamin mit sehr markantem ästhetischen Auftritt stellt diese Verkleidung mit großen Platten aus handgearbeiteter und minuziös mit Basreliefs dekorierter Majolika eine hochklassige Lösung dar. Auf dem Foto das Finish Oro mit Gold-Dekor Damascato. Sockel, Frontblende und Profile aus kugelgestrahltem Stahl.

**FR** Pour une cheminée à fort impact esthétique, ce revêtement, réalisé avec de grands panneaux de faïence façonnée à la main et minutieusement décorée avec des sculptures en bas-relief représente une solution précieuse. En photo, la finition Oro, avec décor Oro Damascato. Base, bande de façade et profils en acier grenailé.

**ES** Para una chimenea de alto impacto estético, este revestimiento, hecho con grandes paneles de mayólica trabajada a mano y minuciosamente decorada con bajorrelieves, representa una solución de gran valor. En la foto, el acabado Oro con decoración en Oro Damascato. Base, frente y perfiles de acero granallado.



#### COLORI - COLOURS

Linea Basic  
Linea Elegance  
Linea Luxury

→ Dettagli - Details P.176



→ Colori - Colours P.19, P.21

→ Focolari compatibili - Compatible fireboxes P.241



# FOX 1

**Caminetto con rivestimento realizzato in grandi pannelli di Maiolica lavorata a mano. Disponibile, oltre che nei colori della famiglia Basic anche con le pregiate finiture delle linee Elegance e Luxury. Anche bifacciale. Base frontalino e profili in acciaio pallinato.**

**EN** A fireplace made with large hand-crafted majolica surround panels. Available in the colours of the Basic range and also with the refined finishes of the Elegance and Luxury ranges. Double-face version also available. Blasted steel base, front element and profiles.

**DE** Kamin mit Verkleidung aus großen, handgearbeiteten Majolika-Platten. In den Farben der Basic-Familie sowie mit den edlen Oberflächenfinishes der Linien Elegance und Luxury erhältlich. Auch zweiseitig. Sockel, Frontblende und Profile aus kugelgestrahltem Stahl.

**FR** Cheminée dont le revêtement est réalisé avec de grands panneaux de faïence façonnée à la main. Outre les couleurs de la famille Basic, ce modèle est aussi disponible dans les finitions précieuses des lignes Elegance et Luxury. Aussi disponible en version double face. Base, bande de façade et profils en acier grenailé.

**ES** Chimenea con revestimiento realizado en grandes paneles de mayólica trabajada a mano. Disponible en los colores de la familia Basic y con los preciados acabados de las líneas Elegance y Luxury. También en doble cara. Base, frente y perfiles de acero granallado.



#### COLORI - COLOURS

Linea Basic  
Linea Elegance  
Linea Luxury

→ Dettagli - Details P.177



→ Colori - Colours P.19, P.21

→ Focolari compatibili - Compatible fireboxes P.241





# WITH YOU

**Originale caminetto con rivestimento in Maiolica lavorata a mano con decori in cristallina. Cornice esterna in acciaio verniciato nero. Disponibile, oltre che nei colori della famiglia Basic anche con le pregiate finiture delle linee Elegance e Luxury. Tra i focolari disponibili c'è anche una versione a legna bifacciale.**

**EN** An original fireplace with hand-crafted majolica surround and crystalline decorations. Black-coated steel outer frame. Available in the colours of the Basic range and also with the refined finishes of the Elegance and Luxury ranges. The firebox models also include a wood-burning double-face version.

**DE** Origineller Kamin mit Verkleidung aus handgearbeiteter Majolika mit Dekors aus Transparentglasur. Äußere Einfassung aus schwarz lackiertem Stahl. In den Farben der Basic-Familie sowie mit den edlen Oberflächenfinishes der Linien Elegance und Luxury erhältlich. Unter den erhältlichen Feuerräumen gibt es auch eine zweiseitige Version für Holzfeuerung.

**FR** Cheminée originale avec revêtement en faïence façonnée à la main avec décors en émail. Cadre extérieur en acier peint noir. Outre les couleurs de la famille Basic, ce modèle est aussi disponible dans les finitions précieuses des lignes Elegance et Luxury. Parmi les foyers disponibles, il existe également une version à bois double face.

**ES** Original chimenea con revestimiento de mayólica trabajada a mano con decoraciones de esmalte vítreo. Marco externo de acero pintado negro. Disponible en los colores de la familia Basic y con los preciados acabados de las líneas Elegance y Luxury. Entre los hogares disponibles hay también una versión de leña de doble cara.



#### COLORI - COLOURS

Linea Basic  
Linea Elegance  
Linea Luxury

→ Dettagli - Details P.179

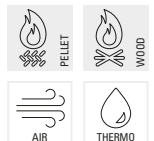

→ Colori - Colours P.19, P.21

→ Focolari compatibili - Compatible fireboxes P.243



# SHUTTLE 1

**Caminetto con rivestimento in Maiolica lavorata a mano con particolari in cristallina. Rialzo e profili in acciaio pallinato. Involucro per tubo di scarico fumi sempre in acciaio pallinato, disponibile nella versione a parete o a soffitto. Oltre che nei colori della famiglia Basic anche con le pregiate finiture delle linee Elegance e Luxury. Anche bifacciale.**

**EN** Fireplace with hand-crafted majolica surround and crystalline details. Blasted steel riser and profiles. Blasted steel flue shell, also available in the wall-mounted or ceiling-mounted version. Available in the colours of the Basic range and also with the refined finishes of the Elegance and Luxury ranges. Double-face version available.

**DE** Kamin mit Verkleidung aus handgearbeiteter Majolika mit Transparentglasur-Details. Aufsatz und Profile aus kugelgestrahltem Stahl, ebenso der Mantel des Rauchabzugsrohrs, das als Wand- oder Deckenversion erhältlich ist. In den Farben der Basic-Familie sowie mit den edlen Oberflächenfinishes der Linien Elegance und Luxury erhältlich. Auch zweiseitig.

**FR** Cheminée avec revêtement en faïence façonnée à la main avec détails en émail. Rehausse et profils en acier grenailé. Cache pour tuyau d'évacuation des fumées lui aussi en acier grenailé, en version murale ou au plafond. Disponible dans les couleurs de la famille Basic et dans les finitions des lignes Elegance et Luxury. Version double face possible.

**ES** Chimenea con revestimiento de mayólica trabajada a mano con detalles de esmalte vítreo. Realce y perfiles de acero granallado. Envoltente de tubo de salida de humos también de acero granallado, disponible en versión de pared o techo. En los colores de la familia Basic y con los preciados acabados de las líneas Elegance y Luxury. También doble cara.



## COLORI - COLOURS

Linea Basic  
Linea Elegance  
Linea Luxury

→ Dettagli - Details P.178



→ Colori - Colours P.19, P.21

→ Focolari compatibili - Compatible fireboxes P.243



# LIFE

**Caminetto importante, realizzato con un rivestimento in grandi pannelli di Maiolica artigianalmente lavorata a mano con particolari in cristallina. Rialzo e profili in acciaio pallinato. Disponibile, oltre che nei colori della famiglia Basic anche con le pregiate finiture delle linee Elegance e Luxury. Anche bifacciale.**

**EN** An imposing fireplace made with large hand-crafted majolica surround panels, featuring crystalline details. Blasted steel riser and profiles. Available in the colours of the Basic range and also with the refined finishes of the Elegance and Luxury ranges. Double-face version also available.

**DE** Eindrucksvoller Kamin mit Verkleidung aus großen, handwerklich gearbeiteten Majolika-Platten mit Details aus Transparentglasur. Aufsatz und Profile aus kugelgestrahltem Stahl. In den Farben der Basic-Familie sowie mit den edlen Oberflächenfinishes der Linien Elegance und Luxury erhältlich. Auch zweiseitig.

**FR** Imposante cheminée avec revêtement constitué de grands panneaux en faïence façonnée artisanalement à la main, avec détails en émail. Rehausse et profils en acier grenailé. Outre les couleurs de la famille Basic, ce modèle est aussi disponible dans les finitions précieuses des lignes Elegance et Luxury. Également disponible en version double face.

**ES** Chimenea importante, realizada con revestimiento en grandes paneles de mayólica artesanalmente trabajada a mano con detalles de esmalte vítreo. Realce y perfiles de acero granallado. Disponible en los colores de la familia Basic y con los preciados acabados de las líneas Elegance y Luxury. También en versión de doble cara.



#### COLORI - COLOURS

Linea Basic  
Linea Elegance  
Linea Luxury

→ Dettagli - Details P.177



→ Colori - Colours P.19, P.21

→ Focolari compatibili - Compatible fireboxes P.242



# SHUTTLE

**Rivestimento in Maiolica lavorata a mano, con superficie decorata e segnatura in bassorilievo, particolari in cristallina. Rialzo e profili in acciaio pallinato. Disponibile, oltre che nei colori della famiglia Basic anche con le pregiate finiture delle linee Elegance e Luxury.**

**EN** Hand-crafted majolica surround with decorated surface and bas-relief stripes, including crystalline details. Blasted steel riser and profiles. Available in the colours of the Basic range and also with the refined finishes of the Elegance and Luxury ranges.

**DE** Verkleidung aus handgearbeiteter Majolika, mit dekoriertes Oberfläche und Basrelief-Zeichnung, Details aus Transparentglasur. Aufsatz und Profile aus kugelgestrahltem Stahl. In den Farben der Basic-Familie sowie mit den edlen Oberflächenfinishes der Linien Elegance und Luxury erhältlich.

**FR** Revêtement en faïence façonnée à la main, avec surface décorée, signature sculptée en bas-relief et détails en émail. Rehausse et profils en acier grenailé. Outre les couleurs de la famille Basic, ce modèle est aussi disponible dans les finitions précieuses des lignes Elegance et Luxury.

**ES** Revestimiento de mayólica trabajada a mano, con superficie decorada y marcas en bajorrelieve y detalles en esmalte vítreo. Realce y perfiles de acero granallado. Disponible en los colores de la familia Basic y con los preciados acabados de las líneas Elegance y Luxury.



## COLORI - COLOURS

Linea Basic  
Linea Elegance  
Linea Luxury

→ Dettagli - Details P.178



→ Colori - Colours P.19, P.21

→ Focolari compatibili - Compatible fireboxes P.243





# FREE

**Prezioso rivestimento in Maiolica lavorata a mano con particolari in cristallina. Ampia cappa e rialzo in acciaio pallinato. Disponibile, oltre che nei colori della famiglia Basic anche con le pregiate finiture delle linee Elegance e Luxury. Anche bifacciale per una visione della fiamma da entrambi i lati.**

**EN** Refined hand-crafted majolica surround with crystalline details. Broad hood and blasted steel riser. Available in the colours of the Basic range and also with the refined finishes of the Elegance and Luxury ranges. Double-face version also available, for viewing the flame from both sides.

**DE** Hochwertige Verkleidung aus handgearbeiteter Majolika mit Details aus Kristall. Breiter Rauchfang und Aufsatz aus kugelgestrahltem Stahl. In den Farben der Basic-Familie sowie mit den edlen Oberflächenfinishes der Linien Elegance und Luxury erhältlich. Auch zweiseitig für die Sicht auf die Flammen von beiden Seiten.

**FR** Revêtement précieux en faïence façonnée à la main avec détails en émail. Grande hotte et rehausse en acier grenailé. Outre les couleurs de la famille Basic, ce modèle est aussi disponible dans les finitions précieuses des lignes Elegance et Luxury. Également disponible en version double face permettant d'admirer la flamme des deux côtés.

**ES** Precioso revestimiento de mayólica trabajada a mano con detalles de esmalte vítreo. Amplia campana y realce de acero granallado. Disponible en los colores de la familia Basic y con los preciados acabados de las líneas Elegance y Luxury. También en versión de doble cara para una visión de la llama desde los dos lados.



#### COLORI - COLOURS

Linea Basic  
Linea Elegance  
Linea Luxury

→ Dettagli - Details P.177



→ Colori - Colours P.19, P.21

→ Focolari compatibili - Compatible fireboxes P.241



# LEEDS

**Sofisticato rivestimento di design per un caminetto a sviluppo verticale. Spalle in Maiolica e moduli frontali semicircolari di grande spessore e superficie, con pregiata lavorazione a bassorilievo realizzata a mano, disponibile in un'ampia gamma di colori. Telaio in acciaio verniciato nero.**

**EN** Sophisticated design surround for a vertically oriented fireplace. Majolica side elements and thick, broad semi-circular front units featuring refined hand-made bas-relief decorations, available in a wide range of colours. Black-coated steel frame.

**DE** Raffinierte Design-Verkleidung für einen vertikal ausgerichteten Kamin. Seitenteile aus Majolika und halbrunde, dickwandige und großflächige Frontmodule mit edlem, handgearbeitetem Basrelief, in einer großen Farbauswahl erhältlich. Rahmen aus schwarz lackiertem Stahl.

**FR** Revêtement design et sophistiqué pour cheminée à développement vertical. Rebords en faïence et modules frontaux en demi-cercle de forte épaisseur et de grande surface, accompagnés de précieuses sculptures en bas-relief réalisées à la main, disponible dans une vaste gamme de couleurs. Cadre en acier peint noir.

**ES** Sofisticado revestimiento de alto diseño para chimeneas verticales. Paneles laterales de mayólica y módulos frontales semicirculares de alto espesor y amplia superficie, con preciada elaboración en bajorrelieve hecha a mano, disponible en una vasta gama de colores. Bastidor de acero pintado negro.



## COLORI - COLOURS

Ardesia	Tabacco
Bianco Antico	Terra Cotta
Bianco Grigio	Tortora
Kaki	
Mattone	
Sahara	
Senape	



→ Colori - Colours P.19

→ Focolari compatibili - Compatible fireboxes P.242



# FENICE

**Importante caminetto realizzato con pannelli di Maiolica di grande spessore caratterizzati dalla loro particolare lavorazione nel decoro. Originale il suo sviluppo frontale ad onda che lo rende sinuoso ed aggraziato. Basamento, profili e particolari in acciaio pallinato. L'ampia cappa è disponibile in acciaio da verniciare o in rame spazzolato.**

**EN** An imposing fireplace made with thick majolica panels characterised by their specially worked decoration. The wavy front profile – a highly original feature – makes it look sinuous and graceful. Blasted steel base, profiles and details. The broad hood is available in the coatable steel or brushed copper version.

**DE** Eindrucksvoller Kamin mit Platten aus dickwandiger Majolika, die sich durch ihre besondere Bearbeitung im Dekor auszeichnen. Originell auch die wellenförmig geschwungene und dadurch graziöse Front. Sockel, Profile und Details aus kugelgestrahltem Stahl. Der breite Rauchfang ist aus zu lackierendem Stahl oder aus gebürstetem Kupfer erhältlich.

**FR** Imposante cheminée réalisée à partir de panneaux de faïence de forte épaisseur caractérisés par le façonnage particulier de leur décor. Son original développement frontal en forme de vague fait de lui un modèle sinueux et gracieux. Base, profils et détails en acier grenailé. La grande hotte est disponible en acier à peindre ou en cuivre brossé.

**ES** Importante chimenea realizada con paneles de mayólica de alto espesor, caracterizados por la particular elaboración de las decoraciones. Original disposición frontal en onda, que le da un toque sinuoso y seductor. Base, perfiles y detalles de acero granallado. La amplia campana está disponible en acero para pintar o en cobre cepillado.



#### COLORI - COLOURS

Grigio Ferro  
Neve



→ Colori - Colours P.19

→ Focolari compatibili - Compatible fireboxes P.241



# DOGE

**Particolarissimo questo caminetto realizzato in Maiolica e acciaio. In un rivestimento a parete di ampia dimensione, con pannelli di grande formato, viene inserito un rivestimento del focolare in acciaio verniciato. Questo caminetto è disponibile per un focolare a legna con apertura a saliscendi.**

**EN** A highly distinctive fireplace made of majolica and steel. The broad wall-mounted surround, consisting of large-size panels, is inserted in the coated steel firebox surround. This fireplace is available with a wood-burning firebox and comes with a vertical lifting door.

**DE** Dieser originelle Kamin ist aus Majolika und Stahl. In eine große wandartige Verkleidung mit großformatigen Platten fügt sich die Verkleidung des Feuerraums aus lackiertem Stahl ein. Dieser Kamin ist für einen Feuerraum für Holzfeuerung mit Hebe- und Senköffnung erhältlich.

**FR** Cette cheminée très particulière est réalisée en faïence et en acier. Le revêtement en acier peint du foyer est inséré au milieu d'un grand revêtement mural constitué de panneaux de grandes dimensions. Cette cheminée est disponible pour un foyer à bois avec ouverture verticale.

**ES** Chimenea extremadamente particular, realizada en mayólica y acero. En un revestimiento de pared amplio, con paneles de formato grande, se inserta un revestimiento del hogar de acero pintado. Esta chimenea es apta para un hogar de leña con apertura por desplazamiento vertical.



#### COLORI - COLOURS

Grigio Ferro  
Moka  
Neve



→ Colori - Colours P.19

→ Focolari compatibili - Compatible fireboxes P.241





# BARCELONA

**Di importante impatto questo rivestimento in Maiolica lavorata a mano rappresenta un importante oggetto di design. La Maiolica di grande spessore ed ampia superficie restituisce tutto il carattere forte di questo oggetto. È possibile realizzare un caminetto con focolare a legna, a pellet, anche in versione Thermo.**

**EN** The hand-worked majolica surround produces a striking impression and is a considerable design element. The bold character of the majolica emerges through its high thickness and broad surface. The fireplace can be designed for burning either wood or pellets, also in the Thermo version.

**DE** Diese wirkungsvolle Verkleidung aus handgefertigter Majolika stellt ein eindrucksvolles Design-Objekt dar. Die dickwandige, großflächige Majolika spiegelt den starken Charakter dieses Objekts vollständig wieder. Es kann ein Kamin mit Feuerraum für Holz- oder Pelletfeuerung realisiert werden, auch als Thermo-Version.

**FR** Ce revêtement en faïence à fort impact visuel façonnée à la main représente un important objet design. La faïence de forte épaisseur et de grande surface révèle le fort caractère de cet objet. Il est possible de réaliser une cheminée avec foyer à bois, à granulés, mais aussi en version thermo.

**ES** Revestimiento de impacto relevante, de mayólica trabajada a mano, que representa un importante objeto de alto diseño. La mayólica de alto espesor y amplia superficie refleja plenamente el acentuado carácter de este objeto. Se puede realizar una chimenea con hogar de leña o pellets también en la versión Thermo.



## COLORI - COLOURS

Grigio Ferro  
Moka  
Neve

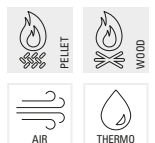

→ Colori - Colours P.19

→ Focolari compatibili - Compatible fireboxes P.240



# PERTH

**Originale per le sue proporzioni e per lo sviluppo verticale il rivestimento di questo caminetto è ottenuto con un unico elemento di Maiolica di grande formato che richiede una grande maestria nell'esecuzione. Sobrio e ricercato sa farsi notare senza eccessi.**

**EN** A highly original solution owing to its proportions and vertical orientation. The surround is made from a single large majolica element that demands skilled workmanship. Sober yet sophisticated, it is conspicuous without excess.

**DE** Die wegen ihrer Proportionen und wegen der vertikalen Anordnung außergewöhnliche Verkleidung dieses Kamins besteht aus einem einzigen großformatigen Majolika-Element, das eine große Meisterschaft in der Ausführung erfordert. Nüchtern und exklusiv setzt sie sich unaufdringlich in Szene.

**FR** Tirant son originalité de ses proportions et de son développement vertical, le revêtement de cette cheminée est obtenu à partir d'un unique élément en faïence de grandes dimensions dont la réalisation nécessite une grande maîtrise. Sobre et recherché, il sait se faire remarquer sans excès.

**ES** Original por sus proporciones y la disposición vertical, el revestimiento de esta chimenea se obtiene a partir de un único elemento de mayólica de gran formato, que requiere una gran maestría en la elaboración. Sobrio y refinado; se hace notar sin excesos.



#### COLORI - COLOURS

Ardesia  
Bianco Antico  
Kaki  
Terra Cotta



→ Colori - Colours P.19

→ Focolari compatibili - Compatible fireboxes P.242



# LANCASTER

**Originale rivestimento per un caminetto a sviluppo verticale. Pannello frontale senza giunzioni, panca e mensole in Maiolica lavorate a mano, disponibile in un'ampia gamma di colori. Rialzo in marmo tinteggiabile a piacere. Telaio in acciaio verniciato nero.**

**EN** Highly original surround for a vertically oriented fireplace. Front panel without any joints, bench and shelf made of hand-crafted majolica, available in a wide range of colours. Coatable marble riser. Black-coated steel frame.

**DE** Originelle Verkleidung für einen vertikal ausgerichteten Kamin. Fugenlose Frontplatte, Sitzbank und Konsole aus handgearbeiteter Majolika, in einer großen Farbauswahl erhältlich. Aufsatz aus Marmor, der nach Belieben eingefärbt werden kann. Rahmen aus schwarz lackiertem Stahl.

**FR** Revêtement original pour cheminée à développement vertical. Façade sans raccords, banquette et étagères en faïence façonnée à la main, disponible dans une large gamme de couleurs. Rehausse en marbre à teinter au gré de ses envies. Cadre en acier peint noir.

**ES** Original revestimiento para una chimenea con disposición vertical. Panel frontal sin juntas, banco y repisas de mayólica elaborados a mano, disponible en una amplia gama de colores. Realce de mármol para pintar al gusto. Bastidor de acero pintado negro.



#### COLORI - COLOURS

Ardesia	Tabacco
Bianco Antico	Terra Cotta
Bianco Grigio	Tortora
Kaki	
Mattone	
Sahara	
Senape	



→ Colori - Colours P.19

→ Focolari compatibili - Compatible fireboxes P.242





# YORK con mensola with shelf

**Rivestimento a sviluppo verticale con pannello frontale, base e mensola in Maiolica disponibile in un'ampia gamma di colori per questa originale soluzione. L'assenza di giunzioni nell'elemento verticale rende la soluzione estetica unica nel suo genere. Telaio in acciaio verniciato nero.**

**EN** Vertically oriented surround with majolica front panel, base and shelf, available in a wide range of colours for this original solution. The absence of joints along the vertical element makes the aesthetic solution unique among its kind. Black-coated steel frame.

**DE** Verkleidung mit vertikaler Ausrichtung, Frontplatte, Sockel und Konsole aus Majolika, die für diese originelle Lösung in großer Farbauswahl erhältlich ist. Die Fugenlosigkeit des vertikalen Elements macht diese Lösung ästhetisch einzigartig. Rahmen aus schwarz lackiertem Stahl.

**FR** Cette solution originale se distingue par son revêtement à développement vertical, avec façade, base et étagère en faïence disponible dans une large gamme de couleurs. L'absence de raccords dans l'élément vertical rend cette solution esthétique unique en son genre. Cadre en acier peint noir.

**ES** Revestimiento con disposición vertical con panel frontal, base y repisa de mayólica disponible en una amplia gama de colores para esta importante chimenea. La ausencia de juntas en el elemento vertical ofrece un aspecto estético único en su género. Bastidor de acero pintado negro.



#### COLORI - COLOURS

Ardesia	Tabacco
Bianco Antico	Terra Cotta
Bianco Grigio	Tortora
Kaki	
Mattone	
Sahara	
Senape	



→ Colori - Colours P.19

→ Focolari compatibili - Compatible fireboxes P.243







# YORK

**Rivestimento a sviluppo verticale con pannello frontale e base in Maiolica disponibile in un'ampia gamma di colori per questo importante caminetto. L'assenza di giunzioni nell'elemento verticale rende la soluzione estetica unica nel suo genere. Telaio in acciaio verniciato nero.**

**EN** Vertically oriented surround with majolica front panel and base, available in a wide range of colours for this imposing fireplace. The absence of joints along the vertical element makes the aesthetic solution unique among its kind. Black-coated steel frame.

**DE** Verkleidung mit vertikaler Ausrichtung, Frontplatte und Sockel aus Majolika, die für diesen eindrucksvollen Kamin in großer Farbauswahl erhältlich ist. Die Fugenlosigkeit des vertikalen Elements macht diese Lösung ästhetisch einzigartig. Rahmen aus schwarz lackiertem Stahl.

**FR** Cette imposante cheminée se distingue par son revêtement à développement vertical, avec façade et base en faïence disponible dans une large gamme de couleurs. L'absence de raccords dans l'élément vertical rend cette solution esthétique unique en son genre. Cadre en acier peint noir.

**ES** Revestimiento con disposición vertical con panel frontal y base de mayólica disponible en una amplia gama de colores para esta importante chimenea. La ausencia de juntas en el elemento vertical ofrece un aspecto estético único en su género. Bastidor de acero pintado negro.



#### COLORI - COLOURS

Ardesia	Tabacco
Bianco Antico	Terra Cotta
Bianco Grigio	Tortora
Kaki	
Mattone	
Sahara	
Senape	



→ Colori - Colours P.19

→ Focolari compatibili - Compatible fireboxes P.243



# DERBY

**Rivestimento con pannello frontale in Maiolica lavorata a mano. L'assenza di giunzioni nell'elemento frontale rende il rivestimento unico e ricercato: un oggetto di design. La lavorazione della Maiolica, apparentemente semplice è estremamente complessa e di difficile realizzazione.**

**EN** Surround with hand-crafted majolica front panel. The absence of joints on the front panel makes the surround unique and refined: a true design object. The apparently simple majolica processing is in fact extremely sophisticated and complex to make.

**DE** Verkleidung mit Frontplatte aus handgearbeiteter Majolika. Die Fugenlosigkeit des Frontelements macht diese Verkleidung einzigartig und exklusiv: ein Design-Objekt. Die scheinbar simple Verarbeitung der Majolika ist extrem komplex und schwierig in der Ausführung.

**FR** Revêtement avec façade en faïence façonnée à la main. L'absence de raccords crée un revêtement unique et recherché : un véritable objet design. Le façonnage de la faïence, qui semble simple à première vue, est extrêmement complexe et difficile à réaliser.

**ES** Revestimiento con panel frontal de mayólica trabajada a mano. La ausencia de juntas en el elemento frontal le da un carácter único y refinado: un objeto de alto diseño. La elaboración de la mayólica, aparentemente simple, es sumamente compleja y laboriosa.



## COLORI - COLOURS

Ardesia	Tabacco
Bianco Antico	Terra Cotta
Bianco Grigio	Tortora
Kaki	
Mattone	
Sahara	
Senape	



→ Colori - Colours P.19

→ Focolari compatibili - Compatible fireboxes P.241



# PORTALE

**Rivestimento in Maiolica lavorata a mano con elementi di grande spessore e dimensione. Design ricco di geometrie. Particolari in acciaio verniciato nero o pallinato a scelta. Carattere deciso e anticonformista.**

**EN** Hand-crafted majolica surround with very thick, large-size elements. Design with a decidedly geometric connotation. Black-coated or blasted steel details. A clear-cut, anti-conventional character.

**DE** Verkleidung aus handgearbeiteter Majolika mit großflächigen, dickwandigen Elementen. Geometrisch reichhaltiges Design. Details wahlweise in schwarz lackiertem oder kugelgestrahltem Stahl. Markanter, antikonformistischer Stil.

**FR** Revêtement en faïence façonnée à la main composé d'éléments de forte épaisseur et de grandes dimensions. Le design se distingue par une foule de motifs géométriques et est agrémenté de détails en acier peint noir ou grenailé, au choix. Un modèle au caractère affirmé et anti-conformiste.

**ES** Revestimiento de mayólica trabajada a mano con elementos de gran espesor y dimensión. Diseño rico de formas geométricas y detalles de acero pintado negro o granallado según la elección. Carácter resuelto y anticonformista.



#### COLORI - COLOURS

Moka  
Neve



→ Colori - Colours P.19

→ Focolari compatibili - Compatible fireboxes P.242



# KOSMOS

**Rivestimento di fine esecuzione in argilla lavorata a mano. I sofisticati decori, anch'essi in argilla, sono frutto di una sapiente lavorazione artigianale. Ogni cornice è un pezzo unico e irripetibile. Disponibile anche in versione bifacciale per una visione della fiamma da entrambi i lati.**

**EN** Finely worked surround made of hand-crafted clay. The sophisticated decorations stem from skilled craftsmanship. Each frame is a single piece that is unique. Also available in the double-face version for viewing the flame from both sides.

**DE** Fein ausgeführte Verkleidung aus handgearbeitetem Ton. Die raffinierten Dekors, ebenfalls aus Ton, sind Ergebnis einer kunstfertigen Bearbeitung. Jede dieser Einfassungen ist ein einmaliges Einzelstück. Auch erhältlich als zweiseitige Version für die Sicht auf die Flammen von beiden Seiten.

**FR** Revêtement en terre façonnée à la main, à l'exécution raffinée. Les décors sophistiqués, eux aussi en argile, sont le fruit d'un savant travail artisanal. Chaque cadre est une pièce unique et inimitable. Également disponible en version double face pour pouvoir admirer la flamme des deux côtés.

**ES** Refinado revestimiento de arcilla trabajada a mano. Las sofisticadas decoraciones, también estas de arcilla, son fruto de una sabia elaboración artesanal. Cada marco es una pieza única e irreplicable. Disponible también en versión de doble cara para una visión de la llama desde los dos lados.



COLORI - COLOURS  
Le Terre



→ Focolari compatibili - Compatible fireboxes P.242





# ARCHEO

**Pregiato rivestimento in argilla artisticamente lavorata a mano. I decori, anch'essi in argilla, sono frutto di una sapiente lavorazione artigianale. Ogni cornice è un pezzo unico e irripetibile. Scegliere un caminetto così particolare significa sapersi concedere il piacere del fuoco avendo il gusto per la preziosità artigianale.**

**EN** Refined clay surround, artistically hand-crafted. The decorations, also made of clay, reflect skilled craftsmanship. Each frame is a unique single piece. Choosing such a distinctive fireplace denotes a passion for enjoying fire and a taste for refined craftsmanship.

**DE** Edle Verkleidung aus kunsthandwerklich verarbeitetem Ton. Die Dekors, auch diese aus Ton, sind Ergebnis einer kunstfertigen Bearbeitung. Jede dieser Einfassungen ist ein einmaliges Einzelstück. Wer sich für ein so besonderes Produkt entscheidet, weiß die Behaglichkeit des Kaminfeuers zu schätzen und beweist Geschmack für das Kunsthandwerk.

**FR** Précieux revêtement en terre façonnée à la main avec art. Les décors, eux aussi en argile, sont le fruit d'un savant travail artisanal. Chaque cadre est une pièce unique et inimitable. Choisir une cheminée si particulière, c'est savoir s'offrir le plaisir du feu en ayant le goût de l'artisanat et de son aspect précieux.

**ES** Preciado revestimiento de arcilla trabajada a mano artísticamente. Las decoraciones, también estas de arcilla, son fruto de una sabia elaboración artesanal. Cada marco es una pieza única e irreplicable. Elegir una chimenea tan especial significa saberse conceder el placer del fuego privilegiando el valor artesanal.



COLORI - COLOURS  
Le Terre



→ Focolari compatibili - Compatible fireboxes P.240



# EOS

**Pregiato rivestimento in argilla lavorata a mano. Particolari i decori anch'essi in argilla, frutto di una sapiente lavorazione artigianale. Ogni cornice è un pezzo unico e irripetibile. Il gusto è quello per gli oggetti ricercati che attirano per l'eleganza, nella loro essenzialità. Unicità e sofisticatezza.**

**EN** Refined hand-crafted clay surround. The decorations, also made of clay, are highly original and stem from skilled craftsmanship. Each frame is a single piece that is unique. The taste reflects a passion for refined objects that are attractively elegant and sober. Uniqueness and sophistication.

**DE** Edle Verkleidung aus handgearbeitetem Ton. Besonders sind auch die Dekore, ebenfalls aus Ton, als Ergebnis einer kunstfertigen Bearbeitung. Jede dieser Einfassungen ist ein einmaliges Einzelstück. Sie entsprechen dem Geschmack für erlesene Objekte, die durch schlichte Eleganz, Einmaligkeit und Raffinesse bestechen.

**FR** Précieux revêtement en terre façonnée à la main. Tout aussi précieux, les décors eux aussi réalisés en argile, sont le fruit d'un savant travail artisanal. Chaque cadre est une pièce unique et inimitable. Ce revêtement exclusif et sophistiqué révèle un goût prononcé des objets recherchés qui séduisent par leur élégance et leur aspect essentiel.

**ES** Preciado revestimiento de arcilla trabajada a mano. Decoraciones particulares, también estas de arcilla, fruto de una sabia maestría artesanal. Cada marco es una pieza única e irreplicable. Predilección por objetos refinados que atraen por su elegancia, en su esencialidad, exclusividad y sofisticación.



**COLORI - COLOURS**  
Le Terre



→ Focolari compatibili - Compatible fireboxes P.241





# WAYS

**Rivestimento in argilla accuratamente lavorata a mano. Gli elaborati decori, anch'essi in argilla, sono frutto di una sapiente lavorazione artigianale. Ogni cornice è un pezzo unico e irripetibile di pregevole valore artistico. Disponibile anche in versione bifacciale per una visione della fiamma da entrambi i lati.**

**EN** Finely hand-crafted clay surround. The sophisticated decorations, also made of clay, stem from skilled craftsmanship. Each frame is a unique single piece with of high artistic worth. Also available in the double-face version for viewing the flame from both sides.

**DE** Verkleidung aus sorgfältig handgearbeitetem Ton. Die ausgefeilten Dekors, ebenfalls aus Ton, sind Ergebnis einer kunstfertigen Bearbeitung. Jede dieser Einfassungen ist ein einmaliges Einzelstück von hohem künstlerischen Wert. Auch erhältlich als zweiseitige Version für die Sicht auf die Flammen von beiden Seiten.

**FR** Revêtement en terre soigneusement façonnée à la main. Les décors élaborés, eux aussi en argile, sont le fruit d'un savant travail artisanal. Chaque cadre est une pièce unique et inimitable d'une haute valeur artistique. Également disponible en version double face pour pouvoir admirer la flamme des deux côtés.

**ES** Revestimiento de arcilla meticulosamente trabajada a mano. Las pulidas decoraciones, también estas en arcilla, son fruto de una sabia elaboración artesanal. Cada marco es una pieza única e irreplicable de preciado valor artístico. Disponible también en versión de doble cara para una visión de la llama desde los dos lados.



**COLORI - COLOURS**  
Le Terre



→ Focolari compatibili - Compatible fireboxes P.243



# PALEO

**Rivestimento in argilla dalla pregiata lavorazione manuale. I decori, anch'essi in argilla, di ricercata esecuzione, sono frutto di una sapiente lavorazione artigianale. Ogni cornice è un pezzo unico e irripetibile. Disponibile anche in versione bifacciale per una visione della fiamma da entrambi i lati.**

**EN** Finely hand-crafted clay surround. The sophisticated decorations, also made of clay, stem from skilled craftsmanship. Each frame is a single piece that is unique. Also available in the double-face version for viewing the flame from both sides.

**DE** Verkleidung aus sorgfältig handgearbeitetem Ton. Die erlesenen Dekors, ebenfalls aus Ton, sind Ergebnis einer kunstfertigen Bearbeitung. Jede dieser Einfassungen ist ein einmaliges Einzelstück. Auch erhältlich als zweiseitige Version für die Sicht auf die Flammen von beiden Seiten.

**FR** Revêtement en terre brillamment façonnée à la main. Les décors sophistiqués, eux aussi en argile, sont le fruit d'un savant travail artisanal. Chaque cadre est une pièce unique et inimitable. Également disponible dans une version double face permettant d'admirer la flamme des deux côtés.

**ES** Revestimiento de arcilla obtenido a partir de una esmerada manufactura. Las refinadas decoraciones, también estas de arcilla, son fruto de una sabia elaboración artesanal. Cada marco es una pieza única e irrepitible. Disponible también en versión de doble cara para una visión de la llama desde los dos lados.



**COLORI - COLOURS**  
Le Terre



→ Focolari compatibili - Compatible fireboxes P.242





# LITHOS

**Rivestimento in argilla sapientemente lavorata a mano. I ricercati decori, anch'essi in argilla, sono frutto di una sapiente lavorazione artigianale. Ogni cornice è un pezzo unico e irripetibile. Disponibile, oltre che nei colori della famiglia Basic anche con le pregiate finiture delle linee Elegance e Luxury. Anche bifacciale.**

**EN** Clay surround skilfully crafted by hand. The refined decorations, also made of clay, reflect skilled artisan workmanship. Each frame is a single piece that is unique. Available in the colours of the Basic range and also with the refined finishes of the Elegance and Luxury ranges. Double-face version also available.

**DE** Verkleidung aus sorgfältig handgearbeitetem Ton. Die erlesenen Dekors, auch diese aus Ton, sind Ergebnis einer kunstfertigen Bearbeitung. Jede dieser Einfassungen ist ein einmaliges Einzelstück. In den Farben der Basic-Familie sowie mit den edlen Oberflächenfinishes der Linien Elegance und Luxury erhältlich. Auch zweiseitig.

**FR** Revêtement en terre savamment façonnée à la main. Les décors recherchés, eux aussi en argile, sont le fruit d'un savant travail artisanal. Chaque cadre est une pièce unique et inimitable. Outre les couleurs de la famille Basic, ce modèle est aussi disponible dans les finitions précieuses des lignes Elegance et Luxury. Version double face possible.

**ES** Revestimiento de arcilla sabiamente trabajada a mano. Las refinadas decoraciones, también estas de arcilla, son fruto de una sabia elaboración artesanal. Cada marco es una pieza única e irrepitible. Disponible en los colores de la familia Basic y con los preciados acabados de las líneas Elegance y Luxury. También en doble cara.



**COLORI - COLOURS**  
Le Terre



→ Focolari compatibili - Compatible fireboxes P.242

# Colori e finiture

**EN** Colours and finishes  
**FR** Couleurs et finitions  
**DE** Farben und Oberflächen  
**ES** Colores y acabados

Elenco completo dei rivestimenti disponibili, oltre che nella linea Basic, anche nelle linee Elegance e Luxury.

**EN** The complete list of available surrounds for the Basic range, as well as for the Elegance and Luxury ranges.

**FR** Liste complète des revêtements disponibles pour la ligne Basic, mais aussi pour les lignes Elegance et Luxury.

**DE** Vollständiges Verzeichnis der Verkleidungen, die über die Basic-Linie hinaus auch in den Linien Elegance und Luxury erhältlich sind.

**ES** Lista completa de los revestimientos disponibles, tanto para la línea Basic como para las líneas Elegance y Luxury.



## CAPITAL

### COLORI - COLOURS

#### LINEA BASIC

Ardesia	Senape
Bianco Grigio	Tabacco
Bianco Antico	Terra Cotta
Bianco	Tortora
Mattone	
Kaki	
Sahara	

#### LINEA ELEGANCE

Bianco Calce	Moka Pennellato
Bianco Setolato	Orange Pennellato
Nero Ingobbio	Prugna
Corallo	Verde Pennellato
Grigio Bruno	Viola Alba
Grigio Metal	Tortora
Grigio Rosso	Tabacco

#### LINEA LUXURY

Oro	Platino Damascato
Oro Decorato	Rame
Oro Damascato	Rame Decorato
Platino	Rame Damascato
Platino Decorato	



## CITY

### COLORI - COLOURS

#### LINEA BASIC

Ardesia	Senape
Bianco Grigio	Tabacco
Bianco Antico	Terra Cotta
Bianco	Tortora
Mattone	
Kaki	
Sahara	

#### LINEA ELEGANCE

Bianco Calce	Moka Pennellato
Bianco Setolato	Orange Pennellato
Nero Ingobbio	Prugna
Corallo	Verde Pennellato
Grigio Bruno	Viola Alba
Grigio Metal	Tortora
Grigio Rosso	Tabacco

#### LINEA LUXURY

Oro	Platino Damascato
Oro Decorato	Rame
Oro Damascato	Rame Decorato
Platino	Rame Damascato
Platino Decorato	



## COLUMBIA

### COLORI - COLOURS

#### LINEA BASIC

Ardesia	Senape
Bianco Grigio	Tabacco
Bianco Antico	Terra Cotta
Bianco	Tortora
Mattone	
Kaki	
Sahara	

#### LINEA ELEGANCE

Bianco Calce	Moka Pennellato
Bianco Setolato	Orange Pennellato
Nero Ingobbio	Prugna
Corallo	Verde Pennellato
Grigio Bruno	Viola Alba
Grigio Metal	Tortora
Grigio Rosso	Tabacco

#### LINEA LUXURY

Oro	Platino Damascato
Oro Decorato	Rame
Oro Damascato	Rame Decorato
Platino	Rame Damascato
Platino Decorato	



## CRUISE

### COLORI - COLOURS

#### LINEA BASIC

Ardesia	Senape
Bianco Grigio	Tabacco
Bianco Antico	Terra Cotta
Bianco	Tortora
Mattone	
Kaki	
Sahara	

#### LINEA ELEGANCE

Bianco Calce	Moka Pennellato
Bianco Setolato	Orange Pennellato
Nero Ingobbio	Prugna
Corallo	Verde Pennellato
Grigio Bruno	Viola Alba
Grigio Metal	Tortora
Grigio Rosso	Tabacco

#### LINEA LUXURY

Oro	Platino Damascato
Oro Decorato	Rame
Oro Damascato	Rame Decorato
Platino	Rame Damascato
Platino Decorato	



## FORUM

### COLORI - COLOURS

#### LINEA BASIC

Ardesia	Senape
Bianco Grigio	Tabacco
Bianco Antico	Terra Cotta
Bianco	Tortora
Mattone	
Kaki	
Sahara	

#### LINEA ELEGANCE

Bianco Calce	Moka Pennellato
Bianco Setolato	Orange Pennellato
Nero Ingobbio	Prugna
Corallo	Verde Pennellato
Grigio Bruno	Viola Alba
Grigio Metal	Tortora
Grigio Rosso	Tabacco

#### LINEA LUXURY

Oro	Platino Damascato
Oro Decorato	Rame
Oro Damascato	Rame Decorato
Platino	Rame Damascato
Platino Decorato	



## FOX

### COLORI - COLOURS

#### LINEA BASIC

Ardesia	Senape
Bianco Grigio	Tabacco
Bianco Antico	Terra Cotta
Bianco	Tortora
Mattone	
Kaki	
Sahara	

#### LINEA ELEGANCE

Bianco Calce	Moka Pennellato
Bianco Setolato	Orange Pennellato
Nero Ingobbio	Prugna
Corallo	Verde Pennellato
Grigio Bruno	Viola Alba
Grigio Metal	Tortora
Grigio Rosso	Tabacco

#### LINEA LUXURY

Oro	Platino Damascato
Oro Decorato	Rame
Oro Damascato	Rame Decorato
Platino	Rame Damascato
Platino Decorato	



## FOX 1

### COLORI - COLOURS

#### LINEA BASIC

Ardesia	Senape
Bianco Grigio	Tabacco
Bianco Antico	Terra Cotta
Bianco	Tortora
Mattone	
Kaki	
Sahara	

#### LINEA ELEGANCE

Bianco Calce	Moka Pennellato
Bianco Setolato	Orange Pennellato
Nero Ingobbio	Prugna
Corallo	Verde Pennellato
Grigio Bruno	Viola Alba
Grigio Metal	Tortora
Grigio Rosso	Tabacco

#### LINEA LUXURY

Oro	Platino Damascato
Oro Decorato	Rame
Oro Damascato	Rame Decorato
Platino	Rame Damascato
Platino Decorato	



## FREE

### COLORI - COLOURS

#### LINEA BASIC

Ardesia	Senape
Bianco Grigio	Tabacco
Bianco Antico	Terra Cotta
Bianco	Tortora
Mattone	
Kaki	
Sahara	

#### LINEA ELEGANCE

Bianco Calce	Moka Pennellato
Bianco Setolato	Orange Pennellato
Nero Ingobbio	Prugna
Corallo	Verde Pennellato
Grigio Bruno	Viola Alba
Grigio Metal	Tortora
Grigio Rosso	Tabacco

#### LINEA LUXURY

Oro	Platino Damascato
Oro Decorato	Rame
Oro Damascato	Rame Decorato
Platino	Rame Damascato
Platino Decorato	



## GALLERY

### COLORI - COLOURS

#### LINEA BASIC

Ardesia	Senape
Bianco Grigio	Tabacco
Bianco Antico	Terra Cotta
Bianco	Tortora
Mattone	
Kaki	
Sahara	

#### LINEA ELEGANCE

Bianco Calce	Moka Pennellato
Bianco Setolato	Orange Pennellato
Nero Ingobbio	Prugna
Corallo	Verde Pennellato
Grigio Bruno	Viola Alba
Grigio Metal	Tortora
Grigio Rosso	Tabacco

#### LINEA LUXURY

Oro	Platino Damascato
Oro Decorato	Rame
Oro Damascato	Rame Decorato
Platino	Rame Damascato
Platino Decorato	



## LIFE

### COLORI - COLOURS

#### LINEA BASIC

Ardesia	Senape
Bianco Grigio	Tabacco
Bianco Antico	Terra Cotta
Bianco	Tortora
Mattone	
Kaki	
Sahara	

#### LINEA ELEGANCE

Bianco Calce	Moka Pennellato
Bianco Setolato	Orange Pennellato
Nero Ingobbio	Prugna
Corallo	Verde Pennellato
Grigio Bruno	Viola Alba
Grigio Metal	Tortora
Grigio Rosso	Tabacco

#### LINEA LUXURY

Oro	Rame Decorato
Oro Decorato	
Platino	
Platino Decorato	
Rame	



## MOOD

### COLORI - COLOURS

#### LINEA BASIC

Ardesia	Senape
Bianco Grigio	Tabacco
Bianco Antico	Terra Cotta
Bianco	Tortora
Mattone	
Kaki	
Sahara	

#### LINEA ELEGANCE

Bianco Calce	Moka Pennellato
Bianco Setolato	Orange Pennellato
Nero Ingobbio	Prugna
Corallo	Verde Pennellato
Grigio Bruno	Viola Alba
Grigio Metal	Tortora
Grigio Rosso	Tabacco

#### LINEA LUXURY

Oro	Platino Damascato
Oro Decorato	Rame
Oro Damascato	Rame Decorato
Platino	Rame Damascato
Platino Decorato	



## PHILADELPHIA

### COLORI - COLOURS

#### LINEA BASIC

Ardesia	Senape
Bianco Grigio	Tabacco
Bianco Antico	Terra Cotta
Bianco	Tortora
Mattone	
Kaki	
Sahara	

#### LINEA ELEGANCE

Bianco Calce	Moka Pennellato
Bianco Setolato	Orange Pennellato
Nero Ingobbio	Prugna
Corallo	Verde Pennellato
Grigio Bruno	Viola Alba
Grigio Metal	Tortora
Grigio Rosso	Tabacco

#### LINEA LUXURY

Oro	Rame Decorato
Oro Decorato	
Platino	
Platino Decorato	
Rame	



## PHOENIX

### COLORI - COLOURS

#### LINEA BASIC

Ardesia	Senape
Bianco Grigio	Tabacco
Bianco Antico	Terra Cotta
Bianco	Tortora
Mattone	
Kaki	
Sahara	

#### LINEA ELEGANCE

Bianco Calce	Moka Pennellato
Bianco Setolato	Orange Pennellato
Nero Ingobbio	Prugna
Corallo	Verde Pennellato
Grigio Bruno	Viola Alba
Grigio Metal	Tortora
Grigio Rosso	Tabacco

#### LINEA LUXURY

Oro	Platino Damascato
Oro Decorato	Rame
Oro Damascato	Rame Decorato
Platino	Rame Damascato
Platino Decorato	



## SAN DIEGO

### COLORI - COLOURS

#### LINEA BASIC

Ardesia	Senape
Bianco Grigio	Tabacco
Bianco Antico	Terra Cotta
Bianco	Tortora
Mattone	
Kaki	
Sahara	

#### LINEA ELEGANCE

Bianco Calce	Moka Pennellato
Bianco Setolato	Orange Pennellato
Nero Ingobbio	Prugna
Corallo	Verde Pennellato
Grigio Bruno	Viola Alba
Grigio Metal	Tortora
Grigio Rosso	Tabacco

#### LINEA LUXURY

Oro	Platino Damascato
Oro Decorato	Rame
Oro Damascato	Rame Decorato
Platino	Rame Damascato
Platino Decorato	



## SHUTTLE

### COLORI - COLOURS

#### LINEA BASIC

Ardesia	Senape
Bianco Grigio	Tabacco
Bianco Antico	Terra Cotta
Bianco	Tortora
Mattone	
Kaki	
Sahara	

#### LINEA ELEGANCE

Bianco Calce	Moka Pennellato
Bianco Setolato	Orange Pennellato
Nero Ingobbio	Prugna
Corallo	Verde Pennellato
Grigio Bruno	Viola Alba
Grigio Metal	Tortora
Grigio Rosso	Tabacco

#### LINEA LUXURY

Oro	Rame Decorato
Oro Decorato	
Platino	
Platino Decorato	
Rame	



## SHUTTLE 1

### COLORI - COLOURS

#### LINEA BASIC

Ardesia	Senape
Bianco Grigio	Tabacco
Bianco Antico	Terra Cotta
Bianco	Tortora
Mattone	
Kaki	
Sahara	

#### LINEA ELEGANCE

Bianco Calce	Moka Pennellato
Bianco Setolato	Orange Pennellato
Nero Ingobbio	Prugna
Corallo	Verde Pennellato
Grigio Bruno	Viola Alba
Grigio Metal	Tortora
Grigio Rosso	Tabacco

#### LINEA LUXURY

Oro	Rame Decorato
Oro Decorato	
Platino	
Platino Decorato	
Rame	



## SIGNS

### COLORI - COLOURS

#### LINEA BASIC

Ardesia	Senape
Bianco Grigio	Tabacco
Bianco Antico	Terra Cotta
Bianco	Tortora
Mattone	
Kaki	
Sahara	

#### LINEA ELEGANCE

Bianco Calce	Moka Pennellato
Bianco Setolato	Orange Pennellato
Nero Ingobbio	Prugna
Corallo	Verde Pennellato
Grigio Bruno	Viola Alba
Grigio Metal	Tortora
Grigio Rosso	Tabacco

#### LINEA LUXURY

Oro	Rame Decorato
Oro Decorato	
Platino	
Platino Decorato	
Rame	



## SUN

### COLORI - COLOURS

#### LINEA BASIC

Ardesia	Senape
Bianco Grigio	Tabacco
Bianco Antico	Terra Cotta
Bianco	Tortora
Mattone	
Kaki	
Sahara	

#### LINEA ELEGANCE

Bianco Calce	Moka Pennellato
Bianco Setolato	Orange Pennellato
Nero Ingobbio	Prugna
Corallo	Verde Pennellato
Grigio Bruno	Viola Alba
Grigio Metal	Tortora
Grigio Rosso	Tabacco

#### LINEA LUXURY

Oro	Platino Damascato
Oro Decorato	Rame
Oro Damascato	Rame Decorato
Platino	Rame Damascato
Platino Decorato	



## SURFACE

### COLORI - COLOURS

#### LINEA BASIC

Ardesia	Senape
Bianco Grigio	Tabacco
Bianco Antico	Terra Cotta
Bianco	Tortora
Mattone	
Kaki	
Sahara	

#### LINEA ELEGANCE

Bianco Calce	Moka Pennellato
Bianco Setolato	Orange Pennellato
Nero Ingobbio	Prugna
Corallo	Verde Pennellato
Grigio Bruno	Viola Alba
Grigio Metal	Tortora
Grigio Rosso	Tabacco

#### LINEA LUXURY

Oro	Rame Decorato
Oro Decorato	
Platino	
Platino Decorato	
Rame	



## VILLAGE

### COLORI - COLOURS

#### LINEA BASIC

Ardesia	Senape
Bianco Grigio	Tabacco
Bianco Antico	Terra Cotta
Bianco	Tortora
Mattone	
Kaki	
Sahara	

#### LINEA ELEGANCE

Bianco Calce	Moka Pennellato
Bianco Setolato	Orange Pennellato
Nero Ingobbio	Prugna
Corallo	Verde Pennellato
Grigio Bruno	Viola Alba
Grigio Metal	Tortora
Grigio Rosso	Tabacco

#### LINEA LUXURY

Oro	Platino Damascato
Oro Decorato	Rame
Oro Damascato	Rame Decorato
Platino	Rame Damascato
Platino Decorato	



## VOYAGER

### COLORI - COLOURS

#### LINEA BASIC

Ardesia	Senape
Bianco Grigio	Tabacco
Bianco Antico	Terra Cotta
Bianco	Tortora
Mattone	
Kaki	
Sahara	

#### LINEA ELEGANCE

Bianco Calce	Moka Pennellato
Bianco Setolato	Orange Pennellato
Nero Ingobbio	Prugna
Corallo	Verde Pennellato
Grigio Bruno	Viola Alba
Grigio Metal	Tortora
Grigio Rosso	Tabacco

#### LINEA LUXURY

Oro	Platino Damascato
Oro Decorato	Rame
Oro Damascato	Rame Decorato
Platino	Rame Damascato
Platino Decorato	



## WITH YOU

### COLORI - COLOURS

#### LINEA BASIC

Ardesia	Senape
Bianco Grigio	Tabacco
Bianco Antico	Terra Cotta
Bianco	Tortora
Mattone	
Kaki	
Sahara	

#### LINEA ELEGANCE

Bianco Calce	Moka Pennellato
Bianco Setolato	Orange Pennellato
Nero Ingobbio	Prugna
Corallo	Verde Pennellato
Grigio Bruno	Viola Alba
Grigio Metal	Tortora
Grigio Rosso	Tabacco

#### LINEA LUXURY

Oro	Platino Damascato
Oro Decorato	Rame
Oro Damascato	Rame Decorato
Platino	Rame Damascato
Platino Decorato	



## ZEUS

### COLORI - COLOURS

#### LINEA BASIC

Ardesia	Senape
Bianco Grigio	Tabacco
Bianco Antico	Terra Cotta
Bianco	Tortora
Mattone	
Kaki	
Sahara	

#### LINEA ELEGANCE

Bianco Calce	Moka Pennellato
Bianco Setolato	Orange Pennellato
Nero Ingobbio	Prugna
Corallo	Verde Pennellato
Grigio Bruno	Viola Alba
Grigio Metal	Tortora
Grigio Rosso	Tabacco

#### LINEA LUXURY

Oro	Platino Damascato
Oro Decorato	Rame
Oro Damascato	Rame Decorato
Platino	Rame Damascato
Platino Decorato	

# Abbinamenti

Combinations  
Associations  
Kombinationen  
Combinaciones

All'ampia scelta di curati ed esclusivi rivestimenti artigianali possono essere abbinati dei focolari a legna o a pellet in grado di riscaldare ambienti di contenute o grandi dimensioni.

**EN** The extensive assortment of refined and exclusive surrounds can be paired with wood-burning or pellet-burning fireboxes capable of heating compact or large environments.

**FR** Au large choix de revêtements artisanaux soignés et exclusifs, il est possible d'associer des foyers à bois ou à granulés en mesure de chauffer des espaces de petites ou grandes dimensions.

**DE** Mit der großen Auswahl an edlen und exklusiven, handwerklich gefertigten Verkleidungen können Holz- oder Pellet-Feuerräume zur Beheizung kleiner oder großer Räume kombiniert werden.

**ES** La amplia selección de refinados y exclusivos revestimientos artesanales pueden combinarse con hogares de leña o pellets capaces de calentar ambientes de dimensiones contenidas o amplias.

Rivestimento - Surround



Combustibile - Fuel



Riscaldamento - Heating



## VERSIONI A CONVEZIONE NATURALE



L'esclusivo piacere del fuoco a legna dei caminetti Piazzetta può essere apprezzato nella collezione *I Veneziani* anche con il sistema di riscaldamento a convezione naturale.

### EN Natural convection versions

Relish the exclusive pleasure of a wood fire in Piazzetta fireplaces through the *I Veneziani* collection also with the natural convection heating system.

### DE Versionen mit Naturkonvektion

Das exklusive Vergnügen des Holzfeuers der Piazzetta Kamine kann bei der Kollektion *I Veneziani* auch mit Naturkonvektions-Heizsystem genossen werden.

### FR Versions à convection naturelle

Le plaisir unique du feu de bois des cheminées Piazzetta peut être apprécié grâce à la collection *I Veneziani*, également disponible avec le système de chauffage à convection naturelle.

### ES Versiones de convección natural

El exclusivo placer del fuego de leña de las chimeneas Piazzetta puede apreciarse en la colección *I Veneziani* también con el sistema de calefacción por convección natural.



## VERSIONI MULTIFUOCO® SYSTEM



Di serie nelle versioni a pellet, disponibile come optional nelle versioni a legna, il sistema di ventilazione forzata Multifuoco® garantisce un riscaldamento uniforme.

### EN Multifuoco® System versions

A standard feature on pellet-burning versions and optional on wood-burning versions, the Multifuoco® forced ventilation system guarantees uniform heating.

### DE Versionen mit Multifuoco® System

Bei den Pelletversionen serienmäßig und bei den Holzversionen als Extra erhältlich, sorgt das Gebläselüftungssystem Multifuoco® für einheitliche Beheizung.

### FR Versions Multifuoco® System

Présent de série dans les versions à granulés, disponible en option dans les versions à bois, le système de ventilation forcée Multifuoco® garantit un chauffage uniforme.

### ES Versiones Multifuoco® System

De serie en las versiones de pellets, disponible con accesorio opcional en las versiones de leña, el sistema de ventilación forzada Multifuoco® garantiza una calefacción uniforme.



## VERSIONI THERMO



Dal piacere della fiamma di un caminetto a legna o a pellet è possibile ricavare anche il calore per alimentare il riscaldamento tradizionale a termosifoni o a pavimento.

### EN Thermo versions

Besides the pleasure it affords, the flame of wood-burning or pellet-burning fireplaces can also generate heat for running traditional radiator-based or underfloor heating systems.

### DE Thermo-Versionen

Das Feuer in einem Holz- oder Pelletkamin ist nicht nur ein Genuss, sondern kann auch Wärme für die herkömmliche Heizung mit Heizkörpern oder Fußbodenheizungen liefern.

### FR Versions Thermo

Outre le plaisir de la flamme d'une cheminée à bois ou à granulés, il est aussi possible d'exploiter la chaleur pour alimenter un système de chauffage traditionnel à radiateurs ou au sol.

### ES Versiones Thermo

Del placer de la llama de una chimenea de leña o pellets se puede obtener también el calor para alimentar la calefacción tradicional con radiadores o de suelo.



# Tecnologia: i focolari

Technology: fireboxes  
Technologie : les monoblocs  
Technologie: Heizeinsätze  
Tecnología: monobloques

Il comfort ed il calore che solo un caminetto Piazzetta è in grado di offrire vengono garantiti dall'accurata progettazione e realizzazione del focolare a legna o pellet. Scegliere un focolare Piazzetta significa contare su una sicurezza certificata, facilità di utilizzo, semplicità di installazione, ridotta manutenzione, ed elevata efficienza. Significa garantirsi le migliori performance, con un costante risparmio nell'impiego, scegliendo tra un'ampia gamma di soluzioni e sistemi di riscaldamento, per il singolo ambiente o l'intera casa, a convezione naturale, Multifuoco® o con focolari Thermo.

**EN** The comfort and heat that only a Piazzetta fireplace can offer stem from the careful design and construction of the wood-burning or pellet-burning firebox. Choosing a Piazzetta firebox means relying on certified safety, ease of use, straightforward installation, low maintenance and high efficiency. It also entails optimal performances that are always cost-efficient, thanks to a broad range of heating solutions and systems, for single rooms or the entire home, based on natural convection, Multifuoco® systems or Thermo fireboxes.

**FR** Le confort et la chaleur que seule une cheminée Piazzetta peut vous offrir sont garantis par la conception et la réalisation soignées du foyer à bois ou à granulés. Choisir un foyer Piazzetta, c'est pouvoir bénéficier des garanties suivantes : sécurité certifiée, facilité d'utilisation, simplicité d'installation, entretien réduit et haute efficacité. C'est pouvoir compter sur les meilleures performances tout en économisant constamment, en faisant son choix parmi une large gamme de solutions et systèmes de chauffage, pour une seule pièce ou pour toute la maison, à convection naturelle, Multifuoco® ou avec un foyer Thermo.

**DE** Komfort und Wärme, wie sie nur ein Piazzetta Kamin bieten kann, sind durch akkurate Planung und Ausführung des Holz- oder Pellet-Feuerraums gewährleistet. Einen Piazzetta Feuerraum zu wählen bedeutet, auf zertifizierte Sicherheit, einfache Benutzung, einfache Installation, geringen Wartungsaufwand und hohe Effizienz zählen zu können. Es bedeutet, sich beste Leistungen mit dauerhafter Ersparnis im Einsatz zu sichern und dabei aus einer breiten Palette an Heizlösungen und -systemen zu wählen, für einzelne Räume oder die gesamte Wohnung, mit Naturkonvektion, Multifuoco® oder mit Thermo-Feuerräumen.

**ES** El confort y el calor que solo una chimenea Piazzetta puede ofrecer se garantizan gracias al esmerado diseño y a la realización del hogar de leña o pellets. Elegir un hogar Piazzetta significa contar con una seguridad certificada, facilidad de uso, sencillez de instalación, bajo mantenimiento y alta eficiencia. Significa garantizarse las mejores prestaciones, con un ahorro constante en el uso, eligiendo entre una amplia gama de soluciones y sistemas de calefacción, para un ambiente preciso o para la vivienda entera, por convección natural, Multifuoco® o con los hogares Thermo.





## ALUKER ALTE PRESTAZIONI

Esclusivo materiale ceramico refrattario brevettato da Piazzetta, che migliora la combustione e la diffusione del calore. Consente un accumulo di energia e resiste a temperature straordinarie. Il suo colore chiaro esalta la luminosità della fiamma.

### EN Aluker High Performance

An exclusive refractory ceramic material patented by Piazzetta that improves combustion and heat diffusion. It allows for storing energy and withstands extreme temperatures. Its light colour enhances the brightness of the flame.

### FR Les hautes performances de l'Aluker

Matériau céramique réfractaire exclusif breveté par Piazzetta, l'Aluker améliore la combustion et la diffusion de la chaleur. Il permet l'accumulation de l'énergie et résiste à des températures exceptionnelles. Sa couleur claire exalte la luminosité de la flamme.

### DE Aluker - Hohe Leistungen

Exklusives, von Piazzetta patentiertes feuerfestes Material, das die Verbrennung und Wärmeverteilung verbessert. Es speichert Energie und ist außerordentlich hitzebeständig. Seine helle Farbe unterstreicht die Leuchtkraft der Flamme.

### ES Aluker de altas prestaciones

Exclusivo material cerámico refractario patentado por Piazzetta, que mejora la combustión y la difusión del calor. Hace posible la acumulación de energía y presenta extraordinaria resistencia a las altas temperaturas. Su color claro exalta el brillo de la llama.

## HI-TECH DETAILS

Le soluzioni progettuali e gli accorgimenti costruttivi adottati fanno di ogni focolare Piazzetta un prodotto tecnologicamente all'avanguardia, realizzato con materiali innovativi di prima qualità. L'assemblaggio nello stabilimento di Asolo è garanzia di lunga durata.

### EN Hi-Tech Details

The design solutions and construction features adopted turn each Piazzetta fireplace into a technologically advanced product made with innovative, premium-quality materials. The assembly at the Asolo plant guarantees long-lasting operation.

### FR Détails Hi-Tech

Les solutions de conception et de fabrication adoptées font de chaque foyer Piazzetta un produit à l'avant-garde de la technologie, réalisé avec des matériaux innovants de première qualité. L'assemblage dans l'établissement d'Asolo est une garantie de longue durée.

### DE Hi-Tech-Details

Die Planungslösungen und die eingesetzten konstruktiven Maßnahmen machen aus jedem Piazzetta Feuerraum ein technologisches Spitzenprodukt aus innovativen Materialien erster Güteklasse. Die Montage im Werk Asolo ist Garant für lange Lebensdauer.

### ES Detalles altamente tecnológicos

Las soluciones de diseño y las técnicas de fabricación adoptadas hacen de cada hogar Piazzetta un producto de vanguardia tecnológica, realizado con materiales innovadores de primera calidad. El ensamblaje en el establecimiento de Asolo es garantía de larga duración.

## PERFORMANCE

L'ampia gamma di focolari Piazzetta consente di trovare il prodotto migliore per realizzare il proprio esclusivo caminetto, da abbinare alla ricchissima gamma di rivestimenti. Concepiti per garantire tutto il piacere del fuoco, offrono la massima efficienza.

### EN Performance

Thanks to the wide range of Piazzetta fireboxes, you can find the best product to create your own exclusive fireplace and pair it with an extensive assortment of surrounds. Designed to enhance the pleasure of fire, they offer the highest level of efficiency.

### FR Performances

La large gamme de foyers Piazzetta permet de trouver le produit idéal pour réaliser sa propre cheminée unique, à associer à une immense gamme de revêtements. Conçus pour garantir tout le plaisir du feu, ils offrent une efficacité maximale.

### DE Leistungsfähigkeit

In der großen Auswahl an Piazzetta Feuerräumen finden Sie das beste Produkt für Ihren exklusiven Kamin, zur Kombination mit der reichhaltigen Auswahl an Verkleidungen. Konzipiert für den uneingeschränkten Genuss des Feuers, bieten sie maximale Effizienz.

### ES Prestaciones

La amplia gama de hogares Piazzetta permite hallar el producto ideal para realizar una chimenea exclusiva, para combinar con la rica gama de revestimientos. Concebidos para garantizar todo el placer del fuego, ofrecen la máxima eficiencia.

# Combustibili

Fuels  
Combustibles  
Brennstoffe  
Combustibles

## La legna

La legna è il combustibile naturale per eccellenza, da sempre fonte primaria per riscaldare e per cucinare. Attorno al fuoco della legna ritroviamo gesti ed emozioni che arrivano dalla storia dell'uomo. La legna da ardere proviene principalmente dall'attività forestale controllata. Accogliere in casa un caminetto a legna significa continuare a coltivare il piacere dello stare insieme.



### DE Wood

Wood is the quintessential natural fuel and has always been a primary source for heating and cooking. Gathering around a wood fire arouses age-old gestures and feelings. Wood fuel comes mainly from monitored forests. Having a wood-burning fireplace at home rekindles the pleasure of sharing pleasant moments together.

### DE Le bois

Le bois est depuis toujours le combustible naturel utilisé pour le chauffage et la cuisine. Autour du feu de bois, nous retrouvons des gestes et des émotions qui remontent à l'aube de notre histoire. Le bois de chauffage provient principalement de l'activité forestière contrôlée. Avoir chez soi une cheminée à bois, c'est continuer de cultiver le plaisir d'être ensemble.

### DE Holz

Holz ist ein hervorragender natürlicher Brennstoff, der schon immer zum Heizen und Kochen verwendet wurde. Am Feuer begegnen wir Gesten und Emotionen, die aus der Menschheitsgeschichte hervorgehen. Brennholz stammt hauptsächlich aus der kontrollierten Forstwirtschaft. Wer sich einen Kamin mit Holzfeuerung ins Haus holt, pflegt das gesellige Beisammensein.

### DE La leña

La leña es el combustible natural por excelencia; fuente primaria sempiterna para calentar y cocinar. En torno al fuego de leña se producen sensaciones y emociones perpetuadas a lo largo de la historia del hombre. La leña proviene principalmente de explotación forestal controlada. Acoger en casa una chimenea de leña significa seguir cultivando el placer de estar juntos.



## Il pellet

L'impiego del pellet, combustibile ecologico da fonti rinnovabili, dall'ottima resa termica, facile da reperire e da gestire nel trasporto e nello stoccaggio, consente un sensibile risparmio in confronto ad altre fonti combustibili, nel pieno rispetto del ciclo naturale. La sua praticità d'uso ne ha garantito la diffusione.

### DE Pellets

The use of pellets – an eco-friendly renewable fuel with excellent heat output that is readily available and easy to store and transport – ensures considerable cost savings compared to other fuels and fully respects the natural cycle. Its practicality makes it very widespread.

### DE Les granulés

L'utilisation des granulés, combustible écologique renouvelable, à l'excellent rendement thermique, facile à trouver et à gérer au niveau transport et stockage, permet de réaliser des économies sensibles par rapport à d'autres combustibles, dans le respect du cycle naturel. C'est sa commodité d'utilisation qui a permis sa large diffusion.

### DE Pellets

Die Verwendung von Pellets, eines ökologischen Brennstoffs aus nachwachsenden Quellen mit optimaler Heizleistung, problemloser Beschaffung und Lagerung, erlaubt nicht nur eine spürbare Ersparnis im Vergleich zu anderen Brennstoffen, sondern auch die Achtung des natürlichen Zyklus. Seine Zweckmäßigkeit hat für seine Verbreitung gesorgt.

### DE El pellet

El empleo del pellet, combustible ecológico de fuentes renovables, de óptimo rendimiento térmico, fácil de conseguir y gestionar en cuanto a transporte y almacenaje, ofrece un considerable ahorro en comparación con otras fuentes combustibles, en pleno respeto del ciclo natural. La comodidad de uso que supone ha garantizado una gran aceptación.



## CAMINETTI A LEGNA



### EN Wood-burning fireplaces

Characterising an environment with the vitality of a wood fire reflects good taste for cherishing pleasant and unforgettable moments.

### FR Cheminées à bois

Distinguer une pièce par la vitalité d'un feu de bois, c'est savoir s'offrir un grand plaisir. Un choix de bon goût pour des moments inoubliables.

### DE Kamine für Holzfeuerung

Die Lebendigkeit eines Holzfeuers in einen Raum zu bringen, bedeutet sich ein großes Vergnügen zu gönnen. Eine Entscheidung des guten Geschmacks für unvergessliche Momente.

### ES Chimeneas de leña

Caracterizar un espacio con la vitalidad de un fuego de leña significa saberse conceder un gran placer. Una elección de buen gusto para momentos inolvidables.

Caratterizzare un ambiente con la vitalità di un fuoco a legna significa sapersi concedere un grande piacere. Una scelta di buon gusto per indimenticabili momenti.



## CAMINETTI A PELLETT



### EN Pellet-burning fireplaces

The heat generated from fire is made available to everyone thanks to the practical pellets, which are easy to use, highly functional and extremely efficient.

### FR Cheminées à granulés

Grâce à la commodité des granulés, la chaleur générée par le feu est désormais à la portée de tous. Simplicité d'emploi, grande fonctionnalité et efficacité extrême.

### DE Kamine für Pelletfeuerung

Pellets haben sich als sehr praktisch erwiesen und damit die Wärme des Feuers für alle greifbar gemacht. Einfacher Einsatz, große Funktionalität und höchste Effizienz.

### ES Chimeneas de pellets

El calor generado por el fuego está hoy al alcance de todos gracias a la comodidad de uso del pellet. Sencillez de uso, gran funcionalidad y extrema eficiencia.

Il calore generato dal fuoco si è reso alla portata di tutti grazie alla praticità d'uso del pellet. Semplicità di impiego, grande funzionalità ed estrema efficienza.

# Multifuoco<sup>®</sup> System

20°C

- **Uniformità di riscaldamento in tutto l'ambiente, dal pavimento al soffitto, senza sprechi.**
- **Definisci la temperatura di comfort, dove tu sei, Multifuoco<sup>®</sup> la mantiene.**
- **Percepisci sempre un calore confortevole in tutto il corpo, mai più piedi freddi.**
- **Uniform heating throughout your living areas, from the floor to the ceiling.**
- **Set you comfort temperature wherever you are and the Multifuoco<sup>®</sup> system will maintain it.**
- **Your body will always feel warm and comfortable; no more cold feet.**
- **Uniformité de chauffage dans toute la pièce du sol au plafond, sans gaspillages.**
- **Définissez la température de confort où vous vous trouvez, Multifuoco<sup>®</sup> se charge de la maintenir.**
- **Une chaleur confortable est perçue dans tout le corps. Vous n'aurez plus jamais les pieds froids.**

20°C

20°C

- Gleichmäßige und sparsame Beheizung des gesamten Raums vom Fußboden bis zur Decke.
- Stellen Sie Ihre gewünschte Komforttemperatur dort ein, wo sie benötigt wird - Multifuoco® hält sie stabil.
- Sie werden immer eine angenehme Wohlfühltemperatur spüren und keine kalten Füße mehr haben.
- Uniformidad de calefacción en todo el ambiente, del suelo al techo, sin desperdicios.
- Elige tu temperatura de confort donde te encuentres. Multifuoco® la mantiene.
- Percibe siempre un calor confortable en todo el cuerpo. Nunca más pies fríos.



# Multifuoco® System

Solo con l'esclusivo Multifuoco® System il calore viene immesso dal basso. Questa caratteristica modalità brevettata consente di mantenere uniforme la temperatura in ambiente, grazie alla generazione di naturali moti convettivi, favoriti dal prelievo dell'aria per il riscaldamento dall'alto.

Multifuoco® System evita di stratificare calore in prossimità del soffitto e riscalda anche all'altezza del pavimento (i nostri piedi). Il calore viene distribuito uniformemente in ambiente, ad elevata temperatura e con una bassa velocità in uscita per garantire la massima silenziosità.

**EN** Only with the exclusive Multifuoco® System, heat is introduced into the room from the floor level. This patented characteristic process maintains a unified room temperature, thanks to the natural convection favorites from levy for heating air from above; where air is warmer. The Multifuoco® System prevents heat stratification occurring at ceiling level rendering more heat at floor level compared to conventional stoves. Heat is conveyed uniformly into the room with maximum silence during operation.

**FR** Seul l'exclusif Multifuoco® System permet l'émission de la chaleur par le bas. Ce mode d'émission breveté permet de garder la température uniforme par génération de mouvements convectifs naturels, favorisés par le prélèvement de l'air de chauffage par le haut. Multifuoco® System évite la stratification de la chaleur près du plafond et chauffe au niveau du sol (pieds). La chaleur est distribuée de façon uniforme, à une température élevée et à faible vitesse en sortie pour un silence assuré.

**DE** Nur mit dem exklusiven Multifuoco® System streicht die Wärme von unten über den Boden in den Raum. Diese patentierte Betriebsweise ermöglicht es, eine einheitliche Temperatur im Raum herzustellen, die durch natürliche Konvektivbewegungen entsteht, wobei die Luft Beheizung aus dem Bereich über dem angesaugt wird. Multifuoco® verhindert somit die Schichtung der Wärme direkt unter der Decke und heizt auch auf Höhe des Bodens (d.h. die Füße). Die Wärme wird gleichmäßig im Raum verteilt; dies erfolgt mit hoher Auslaß-Temperatur und niedriger Geschwindigkeit, um so maximale Laufruhe zu garantieren.

**ES** Sólo con el exclusivo Multifuoco® System el calor se introduce en el ambiente desde abajo. Esta característica modalidad patentada permite mantener uniforme la temperatura ambiente gracias a la generación de movimientos convectivos naturales, favorecidos por la toma del aire de calefacción por la parte superior. Multifuoco® System evita estratificar el calor cerca del techo, calentando también a la altura del suelo (pies). El calor se distribuye uniformemente en el ambiente, a alta temperatura y con una baja velocidad de salida, para garantizar el máximo silencio.

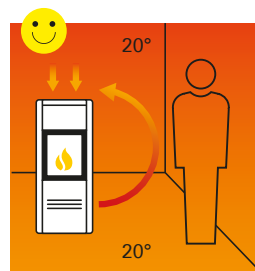

## Riscaldamento Multifuoco® System

**EN** Heating with Multifuoco® System  
**FR** Chauffage Multifuoco® System  
**DE** Beheizung mit Multifuoco® System  
**ES** Calefacción Multifuoco® System

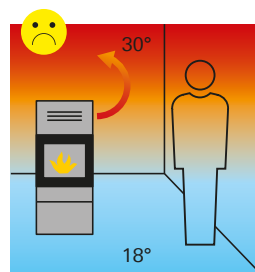

## Riscaldamento tradizionale

**EN** Traditional Heating  
**FR** Chauffage traditionnel  
**DE** Traditionelle Beheizung  
**ES** Calefacción tradicional

**Sistema brevettato**

- EN** Patented system
- FR** Système breveté
- DE** Patentiertes System
- ES** Sistema patentado

**Preriscaldamento aria**

- EN** Warm air
- FR** Préchauffage air
- DE** Vorgewärmte Luft
- ES** Pre calentamiento aire

**Riscaldamento aria**

- EN** Generating hot air
- FR** Chauffage air
- DE** Gewärmte Luft
- ES** Calentamiento aire

**Entrata dell'aria ambiente**

- EN** Ambient air inlet
- FR** Entrée air ambiant
- DE** Eintritt der Raumluft
- ES** Entrada del aire ambiente

**Ventola motore  
Multifuoco<sup>®</sup>**

- EN** Multifuoco<sup>®</sup> blower
- FR** Ventilateur Multifuoco<sup>®</sup>
- DE** Multifuoco<sup>®</sup> Gebläse
- ES** Ventilador del motor Multifuoco<sup>®</sup>

**Uscita aria per canalizzazione**

- EN** Ducting outlet
- FR** Sortie air pour canalisation
- DE** Luftaustritt zur Kanalisierung
- ES** Salida del aire para la canalización

**Uscita aria calda in ambiente**

- EN** Hot air vent
- FR** Sortie air chaud dans la pièce
- DE** Austritt der Warmluft in den Raum
- ES** Salida del aire caliente en el ambiente

# Canalizzazione con Multifuoco®

Attraverso un semplice sistema di canalizzazione, realizzato con tubi flessibili dal diametro ridotto, è possibile riscaldare anche altri ambienti della casa. La diffusione del calore è ancora più confortevole e uniforme, essendo effettuata da più punti, con bocchette dotate di regolazione di flusso. La facile posa dei condotti di canalizzazione consente di realizzare un sistema di riscaldamento versatile, in locali adiacenti o canalizzabili fino a 16 m (pellet). La canalizzazione può essere effettuata orizzontalmente o verticalmente, sia al piano superiore sia a quello inferiore.





**EN Ducting with Multifuoco®**

Other rooms in the home can benefit from this system which can be simply ducted using small diameter flexible duct pipe. Diffusion of heat is even more notable through multiple flow regulating hot air vents positioned in other rooms. Easy laying of the ducting conduits creates a versatile heating system, in adjacent rooms up to 16 metres (pellet). Ducting can be either horizontal or vertical runs and the system will perform on either upper or lower floors.

**FR Canalisation avec Multifuoco®**

A travers un simple système de canalisation, réalisé avec des conduits flexibles de faible diamètre, il est possible de chauffer d'autres pièces de la maison. La diffusion de la chaleur, à travers des bouches de diffusion pourvues d'un réglage de flux, est encore plus confortable et uniforme. La pose aisée des conduits de canalisation permet de réaliser un système de chauffage polyvalent, dans les pièces voisines ou canalisables jusqu'à 16 m (pellet). La canalisation peut être horizontale ou verticale, tant à l'étage supérieur qu'inférieur.

**DE Kanalisierung mit Multifuoco®**

Über ein einfaches Kanalsystem aus flexiblen Rohrleitungen mit reduziertem Durchmesser ist es möglich, auch andere Räume zu beheizen. Die Verteilung der Wärme erfolgt noch komfortabler und gleichmäßiger, da sie an mehreren Stellen über Öffnungen mit Luftstromregulierung austritt. Die problemlose Verlegung der Rohrleitungen erlaubt die Realisierung eines vielseitigen Heizsystems in angrenzende Räume oder mit Kanalisierungen bis 16 m Länge (pellet). Das Kanalsystem kann horizontal bzw. vertikal sowohl in die darüber als auch in die darunter liegende Etage verlegt werden.

**ES Canalización con Multifuoco®**

A través de un simple sistema de canalización, realizado con tubos flexibles de diámetro reducido, es posible calentar también otros ambientes de la casa. La difusión del calor es aún más confortable y uniforme, ya que se efectúa por varios puntos, con bocas dotadas de regulación de flujo. La fácil colocación de los conductos de canalización permite realizar un sistema de calefacción versátil, en ambientes adyacentes o canalizables hasta 16 m (pellet). La canalización puede realizarse horizontal o verticalmente, ya sea sobre el piso superior o el inferior.



Flexible Ducts  
Ø75 mm



# Caratteristiche

## MULTIFUOCO® SYSTEM



Esclusivo sistema di ventilazione brevettato che garantisce una temperatura uniforme in ambiente, dal pavimento al soffitto, senza sprechi: mai più piedi freddi. Canalizzabile in altri ambienti.

### EN Multifuoco® System

An exclusive patented ventilation system that guarantees uniform temperatures within the room, from the floor to the ceiling, without wastages: cold feet are history. Ductable to other rooms.

### FR Multifuoco® System

Système de ventilation exclusif breveté qui garantit une température uniforme dans la pièce, du sol au plafond, sans gaspillage : dites adieu aux pieds froids. Possibilité de canaliser la chaleur vers d'autres pièces.

### DE Multifuoco® System

Das exklusive patentierte Lüftungssystem sorgt für eine gleichmäßige Temperatur im Raum, vom Fußboden bis zur Decke, ohne Verschwendung: nie wieder kalte Füße. Über Kanäle können auch andere Räume mitgeheizt werden.

### ES Multifuoco® System

Exclusivo sistema de ventilación patentado que garantiza una temperatura uniforme en el ambiente, del suelo al techo, sin derroches: adiós a los pies fríos. Canalizable a otros ambientes.



## MULTIFUOCO® SYSTEM PLUS



Per i focolari a legna è possibile scegliere di installare la versione System Plus dell'esclusivo sistema di ventilazione Multifuoco. Questa versione consente un controllo totalmente elettronico della ventola.

### EN Multifuoco® System Plus

The System Plus version of the exclusive Multifuoco ventilation system can be installed on wood-burning fireboxes. This version ensures fully automatic control of the fan.

### FR Multifuoco® System Plus

Pour les foyers à bois, il est possible de choisir d'installer la version System Plus du système exclusif de ventilation Multifuoco. Cette version permet un contrôle entièrement électronique du ventilateur.

### DE Multifuoco® System Plus

Bei Holz-Feuerräumen kann auch die Version System Plus des exklusiven Lüftungssystems Multifuoco installiert werden, mit dem das Gebläse komplett elektronisch gesteuert werden kann.

### ES Multifuoco® System Plus

Para los hogares de leña se puede elegir la versión System Plus con su exclusivo sistema de ventilación Multifuoco. Esta versión permite tener un control totalmente electrónico del ventilador.



## DUAL POWER



Due motori indipendenti garantiscono un flusso di aria calda nei diversi locali. La portata dei motori è modulata separatamente. Disponibile per i focolari a pellet.

### EN Dual Power

Two independent motors ensure a flow of hot air to the various rooms. The capacity of the motors is modulated separately. Available for pellet-burning fireboxes.

### FR Dual Power

Deux moteurs indépendants assurent la distribution de l'air chaud dans les différentes pièces. La portée des moteurs est modulée séparément. Fonction disponible sur les foyers à granulés.

### DE Dual Power

Zwei unabhängige Gebläsemotoren garantieren den Warmluftstrom in die verschiedenen Räume. Die Förderleistung der Gebläsemotoren wird getrennt moduliert. Erhältlich für Pellet-Feuerräume.

### ES Dual Power

Dos motores independientes garantizan un flujo de aire caliente en los distintos ambientes. La capacidad de los motores se modula separadamente. Disponible para los hogares de pellets.



## MULTICOMFORT



Nei focolari a pellet, con la funzione Multicomfort, la temperatura viene rilevata dalla sonda ambiente presente nel telecomando. Per gli inserti IP è possibile collegarsi ad un termostato esterno.

### EN Multicomfort

On pellet-burning fireboxes, with the Multicomfort function, the temperature is measured by the ambient probe fitted in the remote control. For IP inserts, it is possible to connect to an external thermostat.

### FR Multicomfort

Dans les foyers à granulés, avec la fonction Multicomfort, la température est détectée par la sonde ambiante présente dans la télécommande. Les inserts IP permettent la connexion à un thermostat extérieur.

### DE Multicomfort

Bei Pellet-Feuerräumen wird mit der Multicomfort-Funktion die Temperatur durch den Fühler in der Fernbedienung gemessen. Bei den Einsätzen der Baureihe IP kann ein Außenthermostat angeschlossen werden.

### ES Multicomfort

En los hogares de pellets, con la función Multicomfort, la temperatura se detecta mediante la sonda ambiente presente en el mando a distancia. Para los hogares IP, es posible conectarse a un termostato externo.



## SMS - APP



Grazie ad un modulo accessorio, installabile optional, è possibile accendere, spegnere e gestire le funzioni del caminetto a pellet anche quando si è fuori casa, con un sms o mediante l'App My Piazzetta.

### EN Sms - App

Thanks to an ancillary unit installable as an optional feature, it is possible to switch the pellet-burning fireplace on/off and manage its functions even away from home, through a text message or the My Piazzetta app.

### FR Sms - App

Grâce à un module accessoire pouvant être installé en option, il est possible d'allumer, d'éteindre et de gérer les fonctions de la cheminée à granulés à distance, par SMS ou par le biais de l'application My Piazzetta.

### DE Sms - App

Dank eines optional installierbaren Moduls können Sie den Kamin mit einer SMS oder über die App My Piazzetta auch dann ein-/ausschalten und seine Funktionen steuern, wenn Sie außer Haus sind.

### ES Sms - App

Gracias a un módulo adicional que puede instalarse como elemento opcional, es posible encender, apagar y gestionar las funciones de la chimenea aun estando fuera de casa, por sms o mediante la App My Piazzetta.



## EASY TO CLEAN



Un capiente cassetto di raccolta della cenere, in acciaio verniciato, di elevato spessore, comodamente estraibile e semplice da svuotare, rende particolarmente agili e pratiche le operazioni di pulizia.

### EN Easy to clean

A high-thickness, spacious ash tray made of painted steel, easy to remove and to empty, makes cleaning operations very quick and easy.

### FR Facilité de nettoyage

Grâce au grand tiroir à cendres en acier peint de forte épaisseur, coulissant et simple à vider, les opérations de nettoyage sont particulièrement faciles et pratiques.

### DE Einfach zu reinigen

Ein Aschekasten mit großem Fassungsvermögen aus lackiertem Stahl mit hoher Wandstärke, ausziehbar und leicht zu entleeren, macht das Reinigen besonders bequem und einfach.

### ES Limpieza fácil

Un espacioso cajón de cenizas de acero pintado de alto espesor, fácil de extraer y de vaciar, agiliza al máximo las operaciones de limpieza.



# Caratteristiche

## STEEL STRUCTURE



La solidità di costruzione dei caminetti Piazzetta garantisce che mantengano le loro caratteristiche nel tempo, grazie ad un'accurata progettazione e alla qualità dell'acciaio di forte spessore.

### EN Steel structure

The sturdy structure of Piazzetta fireplaces ensures that they retain their characteristics over time, thanks to attentive design and the premium-quality, high-thickness steel.

### FR Structure en acier

La solidité de fabrication des cheminées Piazzetta garantit la préservation de leurs caractéristiques dans le temps, grâce à une conception soignée et à la qualité de l'acier de forte épaisseur.

### DE Stahlkonstruktion

Die solide Konstruktion der Piazzetta Kamine sorgt dafür, dass sie ihre Eigenschaften dauerhaft beibehalten. Sie sind sorgfältig konstruiert und aus hochwertigem Stahl mit hoher Wandstärke gefertigt.

### ES Estructura de acero

La solidez de construcción de las chimeneas Piazzetta garantiza el mantenimiento de sus características a lo largo del tiempo, gracias a un atento diseño y la calidad del acero de alto espesor.



## GOOD HEAT OUTPUT



La qualità di distribuzione del calore in ambiente garantisce il massimo comfort e la regolazione del livello di calore consente di ottenere il miglior beneficio ed efficienza del fuoco a legna e a pellet.

### EN Good Heat Output

The quality of the heat distribution throughout the room ensures maximum comfort, while the heat level adjustment allows for taking full advantage of the wood and pellet fire's efficiency.

### FR Bonne puissance calorifique

La qualité de répartition de la chaleur dans la pièce garantit un confort maximal et la régulation du niveau de chaleur permet de tirer le meilleur bénéfice possible du feu de bois et des granulés.

### DE Gute Wärmeabgabe

Die gute Wärmeverteilung im Raum sorgt für höchsten Komfort. Durch die Regelung der Wärmeabgabe können Nutzen und Effizienz der Holz- bzw. Pelletfeuerung optimiert werden.

### ES Buena salida de calor

La calidad de distribución del calor en el ambiente garantiza el máximo confort, mientras que la regulación del nivel de calor permite obtener los más altos valores de utilidad y eficiencia del fuego de leña y pellets.



## EXTERNAL AIR KIT



I focolari a legna e a pellet possono essere dotati di un kit per prelevare l'aria comburente dall'esterno, evitando di sottrarre aria ed ossigeno dall'ambiente. Soluzione efficace in qualsiasi tipo di abitazione.

### EN External Air Kit

The wood-burning and pellet-burning fireboxes can be fitted with a kit for drawing primary combustion air from the outside, so as to avoid using up the air and oxygen inside the room. An effective solution for any type of home.

### FR Kit air extérieur

Les foyers à bois et à granulés peuvent être équipés d'un kit pour prélever l'air comburant à l'extérieur, évitant de puiser l'air et l'oxygène dans la pièce. Une solution efficace pour n'importe quel type d'habitation.

### DE Außenluft-Bausatz

Die Holz- und Pellet-Feuerräume können mit einem Bausatz ausgerüstet werden, der die Verbrennungsluft von außen zuführt, damit dem Wohnraum kein Sauerstoff entzogen wird: eine optimale Lösung für jede Wohnung.

### ES Kit de aire exterior

Los hogares de leña y pellets pueden dotarse de un kit para tomar el aire de combustión del exterior, sin robar aire y oxígeno al ambiente. Solución eficaz en cualquier tipo de vivienda. cualquier tipo de vivienda.



## RISE N' FALL DOOR



Differenti modalità di apertura dell'anta del focolare consentono un'ampia varietà di installazioni semplificando l'apertura e facilitando il caricamento della legna, assecondando le varie necessità.

### EN Rise N' Fall Door

Different methods for opening the firebox door ensure a wide variety of installation options to simplify the door opening and wood loading operations, to suit any requirement.

### FR Porte relevable

Les différentes modalités d'ouverture de la porte du foyer permettent une grande variété d'installations, simplifiant l'ouverture et facilitant le chargement du bois en respectant les différents besoins.

### DE Hebe- und Senktür

Unterschiedliche Öffnungsarten der Feuerraumtür ermöglichen zahlreiche Installationsvarianten. Diese vereinfachen das Öffnen und erleichtern das Einlegen des Holzes, je nach Bedarf.

### ES Puerta corredera vertical

Las distintas modalidades de apertura de la puerta del hogar ofrecen una amplia variedad de instalaciones, para simplificar la apertura y la carga de la leña, según las necesidades específicas.



## PELLET LEVEL SENSOR



Dotati di numerose funzioni per una facile gestione, i focolari a pellet, grazie ad un sensore nel serbatoio, sono in grado di inviare sul telecomando un avviso quando è necessaria una ricarica.

### EN Pellet level sensor

Equipped with several functions to facilitate their management, the pellet-burning fireboxes – thanks to a sensor fitted in the tank – are able to send an alert message to the remote control when they need to be reloaded.

### FR Capteur de niveau des granulés

Dotés de nombreuses fonctions pour faciliter la gestion, les foyers à granulés, grâce à un capteur présent dans le réservoir, peuvent envoyer une notification sur la télécommande quand il faut remettre des granulés.

### DE Pellet-Füllstandsensor

Die Pellet-Feuerräume sind mit zahlreichen Funktionen für einfache Bedienung ausgerüstet. Über einen Sensor im Behälter sind sie in der Lage, an die Fernbedienung eine Warnung zu senden, wenn nachgefüllt werden muss.

### ES Sensor de nivel del pellet

Los hogares de pellets, provistos de numerosas funciones que facilitan la gestión, cuentan con un sensor en el depósito que les permite avisar al mando a distancia si requieren una recarga.



## MULTIFUNCTION REMOTE CONTROL



Con un pratico telecomando, che rileva anche la temperatura ambiente, è possibile gestire tutte le funzioni, impostando le modalità di impiego del focolare a pellet, anche attraverso una programmazione.

### EN Multifunction Remote Control

A practical remote control, which also measures the ambient temperature, allows for managing all the functions by setting the operating modes of the pellet-burning firebox, also through programming.

### FR Télécommande multifonctions

Avec une télécommande très pratique, qui détecte également la température ambiante, il est possible de gérer toutes les fonctions en paramétrant les modalités d'utiliser du foyer à granulés, même par programmation.

### DE Multifunktionale Fernbedienung

Über eine praktische Fernbedienung, die auch die Raumtemperatur misst, können sämtliche Funktionen gesteuert werden. Dazu können die Betriebsarten des Pellet-Feuerraums eingestellt bzw. programmiert werden.

### ES Mando a distancia multifunción

Un práctico mando a distancia, que además detecta la temperatura ambiente, permite administrar todas las funciones, configurando las modalidades de uso del hogar de pellets, gracias también a la programación.



# MC BL



MC 80/64 BL



## FOCOLARI COMPATTI CON ANTA BASCULANTE

Perfetta sintesi di tecnologia all'avanguardia e pulizia estetica. La serie di Focolari Compatti MC a legna, offre innumerevoli soluzioni d'installazione in poco spazio. Nuove forme moderne e vetro serigrafato incorniciano il fuoco e lo rendono il protagonista della casa.

### EN Compact fireboxes with tilting door

A perfect blend of cutting-edge technology and sober aesthetics. The wood-burning MC Compact Firebox range offers countless installation solutions in limited spaces. New modern profiles and screen-printed glass enclose the fire, making it the distinctive feature of the home.

### DE Kompakte heizeinsätze mit tür

Die perfekte Synthese von Technologie und sauberen Linien. Die kompakten Heizeinsätze der Baureihe MC für Holzfeuerung lassen zahlreiche Installationslösungen auf geringem Raum zu. Neue, moderne Formen und Glas mit Siebdruck rahmen das Feuer ein, das somit zum Mittelpunkt des Hauses wird.

### FR Monoblocs compacts avec porte basculante

Synthèse parfaite de technologie et de sobriété esthétique, la série des monoblocs compacts MC offre d'innombrables solutions d'installation dans les espaces réduits. Les nouvelles formes modernes et la vitre sérigraphiée encadrent le feu et font de lui un acteur à part entière de la maison.

### ES Monobloques compactos con puerta basculante

Perfecta síntesis de tecnología de vanguardia y prolijidad estética. La serie de Monobloques Compactos MC de leña ofrece innumerables soluciones de instalación para espacios pequeños. Las formas modernas y el vidrio serigrafiado enmarcan el fuego y lo hacen protagonista del hogar.



Type  
MC 65/60



kW Nom.  
11,0



%  
80,0



m<sup>3</sup>  
185 - 315



kg/h  
3,1



cm  
18



kg  
175



cm (WxDxH)  
83x48x77

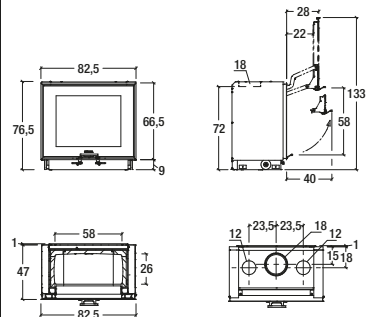

Model: MC 80/64 BL



Rivestimenti disponibili - Available surrounds P.244

# MC 85/55 BL



<b>Type</b> MC 70/51	<b>kW Nom.</b> 11,0
<b>%</b> 79,0	<b>m³</b> 185 - 315
<b>kg/h</b> 2,9	<b>cm</b> 18
<b>kg</b> 160	<b>cm (WxDxH)</b> 88x48x68

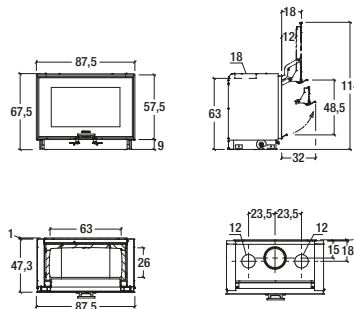

Model: MC 85/55 BL

Rivestimenti disponibili - Available surrounds P.244

Focolari

# MC 105/48 BL



<b>Type</b> MC 90/44	<b>kW Nom.</b> 12,2
<b>%</b> 79,3	<b>m³</b> 205 - 350
<b>kg/h</b> 3,2	<b>cm</b> 20
<b>kg</b> 180	<b>cm (WxDxH)</b> 108x48x61

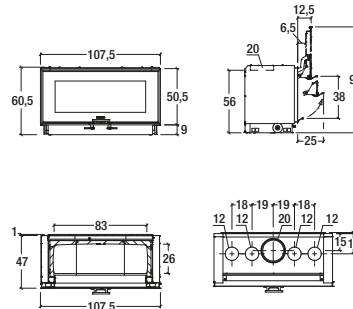

Model: MC 105/48 BL

Rivestimenti disponibili - Available surrounds P.244

# MC 133/52 BL



<b>Type</b> MC 120/48	<b>kW Nom.</b> 14,1
<b>%</b> 78,9	<b>m³</b> 235 - 405
<b>kg/h</b> 3,8	<b>cm</b> 20
<b>kg</b> 230	<b>cm (WxDxH)</b> 136x47x65

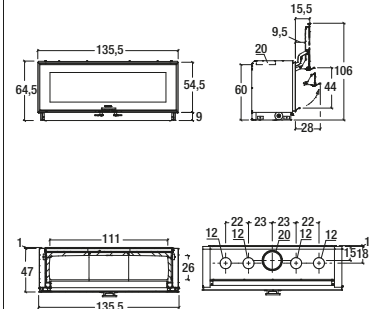
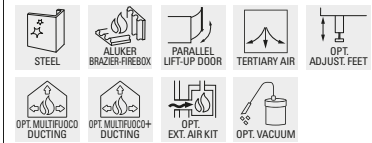

Model: MC 133/52 BL

Rivestimenti disponibili - Available surrounds P.244

# MC SL



MC 65/60 SL



## FOCOLARI COMPATTI CON ANTA SALISCENDI

I Focolari Compatti MC SL a legna, fondono pulizia estetica e praticità d'utilizzo grazie alla pratica e funzionale apertura a saliscendi che scorre a scomparsa verso l'alto. L'ampio vetro serigrafato consente di godere di una piacevole visione della fiamma. L'estrema linearità costruttiva offre innumerevoli soluzioni d'installazione.

### EN Compact fireboxes with lifting door

The wood-burning MC SL Compact Fireboxes blend sober aesthetics and ease of use thanks to the practical and functional lifting system that slides upwards and is concealed when open. The broad screen-printed glass ensures a pleasant view of the flame. Their extremely linear forms guarantee countless installation options.

### FR Monoblocs compacts avec porte à ouverture verticale

Les monoblocs compacts MC SL associent sobriété esthétique et commodité d'utilisation grâce à leur porte très pratique à ouverture verticale qui disparaît en coulissant vers le haut. La grande vitre sérigraphiée assure une agréable vision de la flamme. L'extrême linéarité de construction offre d'innombrables solutions d'installation.

### DE Kompakte heizeinsätze mit öffnung durch hebe- und senksystem

Die kompakten Heizeinsätze MC SL für Holzfeuerung vereinen saubere Linien und Benutzerfreundlichkeit mit dem praktischen und funktionalen Hebe- und Senksystem zum Öffnen der Tür. Die große Scheibe mit Siebdruck bietet eine angenehme Sicht auf die Flamme. Die strikte Linearität dieses Produkts lässt zahlreiche Installationslösungen zu.

### ES Monobloques compactos con puerta corredera vertical

Los Monobloques Compactos MC SL de leña unen la prolijidad estética a la comodidad de uso gracias a la práctica y funcional apertura por desplazamiento vertical escamoteable. El amplio vidrio serigrafiado permite disfrutar de una agradable vista de la llama. La extrema linealidad constructiva ofrece innumerables soluciones de instalación.



	<b>Type</b> MC 65/60		<b>kW NOM.</b> 11,0
	<b>%</b> 80,0		<b>m<sup>3</sup></b> 185 - 315
	<b>kg/h</b> 3,1		<b>cm</b> 18
	<b>kg</b> 202		<b>cm (WxDxH)</b> 73x51x136

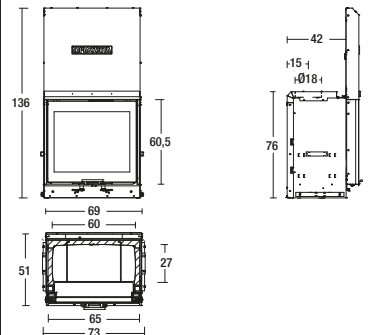

Model: MC 65/60 SL



Rivestimenti disponibili - Available surrounds P.244



# MC 70/51 SL



	<b>Type</b> MC 70/51		<b>kW Nom.</b> 11,0
	<b>%</b> 79,0		<b>m³</b> 185 - 315
	<b>kg/h</b> 2,9		<b>cm</b> 18
	<b>kg</b> 195		<b>cm (WxDxH)</b> 78x51x118

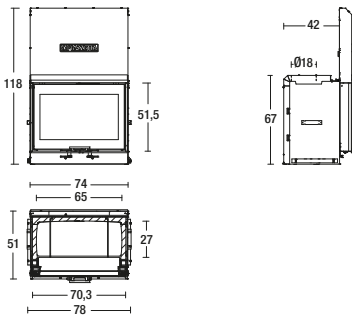

Model: MC 70/51 SL

Rivestimenti disponibili - Available surrounds P.244

# MC 90/44 SL



	<b>Type</b> MC 90/44		<b>kW Nom.</b> 12,2
	<b>%</b> 79,3		<b>m³</b> 205 - 350
	<b>kg/h</b> 3,2		<b>cm</b> 20
	<b>kg</b> 160		<b>cm (WxDxH)</b> 98x51x104

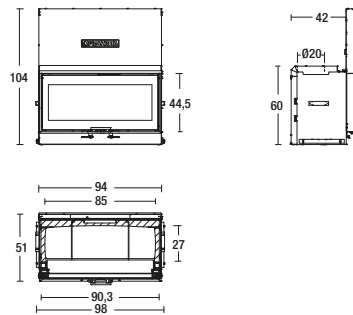

Model: MC 90/44 SL

Rivestimenti disponibili - Available surrounds P.244

# MC 120/48 SL



	<b>Type</b> MC 120/48		<b>kW Nom.</b> 14,1
	<b>%</b> 78,9		<b>m³</b> 235 - 405
	<b>kg/h</b> 3,8		<b>cm</b> 20
	<b>kg</b> 280		<b>cm (WxDxH)</b> 126x51x112

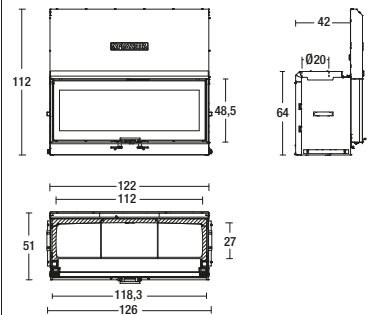

Model: MC 120/48 SL

Rivestimenti disponibili - Available surrounds P.244

# MC



## MC 65/60 PLUS



### FOCOLARI COMPATTI

La serie Focolari Compatti MC a legna offre innumerevoli soluzioni di installazione grazie all'estrema linearità costruttiva. Nuove forme moderne e vetro serigrafato incorniciano il fuoco e lo rendono il protagonista della casa. Ampio piano fuoco e doppio sistema di aria terziaria preriscaldata che ottimizza la combustione e i rendimenti. Porta reversibile con maniglia a scomparsa.

#### EN Compact fireboxes

The wood-burning MC Compact Firebox range offers countless installation options thanks to extremely linear profiles. New modern forms and screen-printed glass enclose the fire, making it the distinctive feature of the home. Broad hearth and dual system for pre-heated tertiary air that optimises combustion and performances. Reversible door with recessed handle.

#### FR Monoblocs compacts

La série de monoblocs compacts MC offre une foule de solutions d'installation grâce à son extrême linéarité de construction. Les nouvelles formes modernes et la vitre sérigraphiée encadrent le feu et de lui la star de la maison. Large sole foyer et double système d'air tertiaire préchauffé optimisant la combustion et les rendements. Porte réversible avec poignée escamotable.

#### DE Kompakte heizeinsätze

Die kompakten Heizeinsätze der Baureihe MC für Holzfeuerung lassen dank strikter Linearität zahlreiche Installationslösungen zu. Moderne Formen und Glas mit Siebdruck umrahmen das Feuer und machen es zum Mittelpunkt des Hauses. Großer Feuertisch und doppeltes System für vorgewärmte Tertiärluft zur Verbrennungs- und Leistungsoptimierung. Umkehrbare Tür mit versenkbarem Griff.

#### ES Monobloques compactos

La serie Monobloques Compactos MC de leña ofrece numerosas opciones de instalación gracias a la extrema linealidad constructiva. Las formas modernas y el vidrio serigrafiado enmarcan el fuego y lo hacen protagonista del hogar. Amplio plano de fuego y doble sistema de aire terciario precalentado que optimiza la combustión y el rendimiento. Puerta reversible con tirador abatible.



Type  
MC 65/60  
PLUS



kW Nom.  
11,0



%  
≥85,0



m<sup>3</sup>  
185 - 315



kg/h  
3,1



cm  
18



kg  
175



cm (WxDxH)  
74x47x122

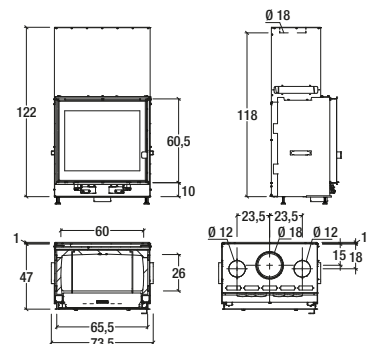

Model: MC 65/60 P



Rivestimenti disponibili - Available surrounds P.244

# MC 65/60



<b>Type</b> MC 65/60	<b>kW Nom.</b> 11,0
<b>%</b> 80,0	<b>m³</b> 185 - 315
<b>kg/h</b> 3,1	<b>cm</b> 18
<b>kg</b> 155	<b>cm (WxDxH)</b> 74x48x76

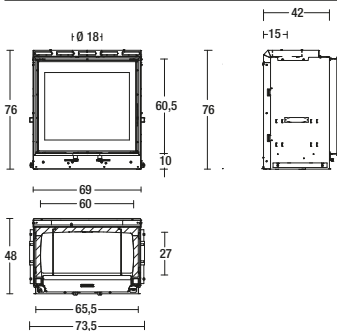

Model: MC 65/60

Rivestimenti disponibili - Available surrounds P.244

# MC 70/51



<b>Type</b> MC 70/51	<b>kW Nom.</b> 11,0
<b>%</b> 79,0	<b>m³</b> 185 - 315
<b>kg/h</b> 2,9	<b>cm</b> 18
<b>kg</b> 140	<b>cm (WxDxH)</b> 71x48x67

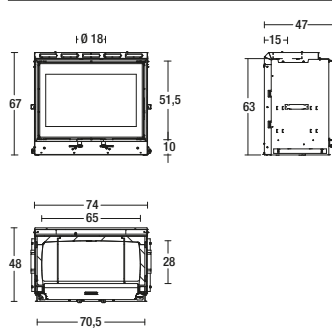

Model: MC 70/51

Rivestimenti disponibili - Available surrounds P.244

# MC 90/44 PLUS



<b>Type</b> MC 90/44 PLUS	<b>kW Nom.</b> 12,2
<b>%</b> ≥85,0	<b>m³</b> 205 - 350
<b>kg/h</b> 3,2	<b>cm</b> 20
<b>kg</b> 180	<b>cm (WxDxH)</b> 99x47x106

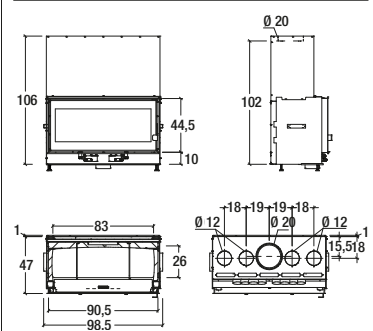

Model: MC 90/44 P

Rivestimenti disponibili - Available surrounds P.244

# MC 90/44



# MC 120/48



	<b>Type</b> MC 90/44		<b>kW Nom.</b> 12,2
	<b>%</b> 79,3		<b>m<sup>3</sup></b> 205 - 350
	<b>kg/h</b> 3,2		<b>cm</b> 20
	<b>kg</b> 160		<b>cm (WxDxH)</b> 99x48x60

	<b>Type</b> MC 120/48		<b>kW Nom.</b> 14,1
	<b>%</b> 78,3		<b>m<sup>3</sup></b> 235 - 405
	<b>kg/h</b> 3,8		<b>cm</b> 20
	<b>kg</b> 200		<b>cm (WxDxH)</b> 126x48x64

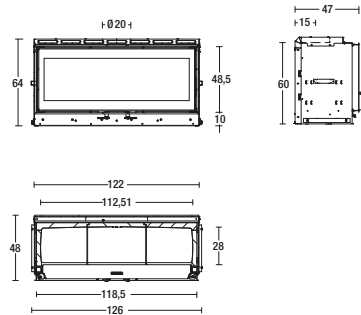
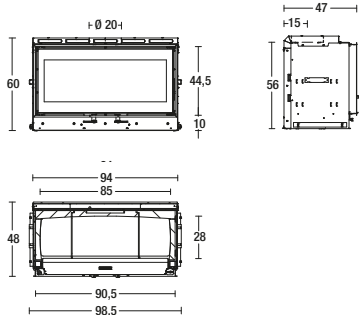

Model: MC 90/44

Model: MC 120/48

Rivestimenti disponibili - Available surrounds P.244

Rivestimenti disponibili - Available surrounds P.244

# MA SL



MA 260 SL



## FOCOLARI COMPATTI CON ANTA SALISCENDI

Nei focolari MA SL a legna si fondono la dimensione generosa tipica del focolare tradizionale a legna, il disegno moderno e l'apertura con anta saliscendi che lo rendono particolarmente funzionale. Si può godere del crepitio della legna tenendo l'anta parzialmente aperta o scegliere di sfruttare il kit cottura per piacevoli serate con gli amici.

### EN Compact fireboxes with lifting door

The MA SL wood-burning fireboxes combine the broad dimensions typical of traditional wood-burning fireplaces, modern design and the lifting door, which make the products highly functional. Opening the door partly allows for enjoying the crackling sound of fire, or using the cooking kit ensures a pleasant evening with friends.

### FR Monoblocs compacts avec porte à ouverture verticale

Particulièrement fonctionnels, les monoblocs MA SL à bois réunissent la dimension généreuse typique des foyers traditionnels, un design moderne et une ouverture verticale. En laissant la porte partiellement ouverte, on pourra profiter du crépitement du feu. Pour d'agréables soirées entre amis, on choisira d'utiliser le kit de cuisson.

### DE Kompakte heizeinsätze mit öffnung durch hebe- und senksystem

Die Heizeinsätze MA SL für Holzfeuerung vereinen die großzügigen Maße herkömmlicher Holz-Feuerräume mit modernem Design und besonders funktionaler Öffnung mit Hebe-/Senksystem. Um das Knistern des Holzes zu genießen, kann die Tür leicht geöffnet gehalten oder das Cooking-Pro Set für gemütliche Abende mit Freunden genutzt werden.

### ES Monobloques compactos con puerta corredera vertical

El monobloque MA SL de leña une el amplio tamaño típico del hogar tradicional de leña, un diseño moderno y la apertura con puerta corredera vertical, para ofrecer alta funcionalidad. Es posible disfrutar del crujido de la leña manteniendo la puerta parcialmente abierta o utilizar el kit de cocción para agradables veladas con amigos.



Type  
MA 260 SL



kW Nom.  
12,5



%  
75,5



m<sup>2</sup>  
210 - 360



kg/h  
3,6



cm  
20



kg  
157



cm (WxDxH)  
85x53x128

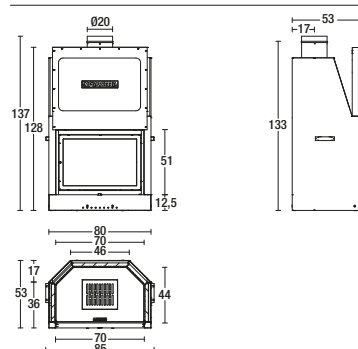

Model: MA 260 SL



Rivestimenti disponibili - Available surrounds P.244

# MA 260 B SL



<b>Type</b> MA 260 B SL	<b>kW Nom.</b> 13,5
<b>%</b> 75,0	<b>m<sup>3</sup></b> 225 - 390
<b>kg/h</b> 4,2	<b>cm</b> 20
<b>kg</b> 180	<b>cm (WxDxH)</b> 87x53x129

- STEEL
- ALUKER FIREBOX CAST-IRON BRAZIER
- RISE N'FALL DOOR
- ASH BOX
- MANUAL DAMPER FLUE
- OPT. EXT. AIR KIT
- OPT. ADJUST. FEET
- OPT. LEVELLING FEET
- OPT. LOG RETAINER
- OPT. VACUUM

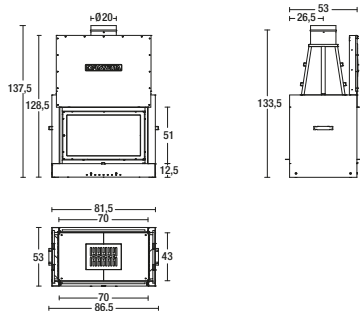

Model: MA 260 B SL

Rivestimenti disponibili - Available surrounds P.244

# MA 261 SL



<b>Type</b> MA261SL-01	<b>kW Nom.</b> 13,5
<b>%</b> 77,8	<b>m<sup>3</sup></b> 225 - 390
<b>kg/h</b> 4,0	<b>cm</b> 25
<b>kg</b> 206	<b>cm (WxDxH)</b> 94x65x135

- STEEL
- ALUKER FIREBOX CAST-IRON BRAZIER
- RISE N'FALL DOOR
- ASH BOX
- MANUAL DAMPER FLUE
- OPT. EXT. AIR KIT
- OPT. ADJUST. FEET
- OPT. LEVELLING FEET
- OPT. LOG RETAINER
- OPT. COOKING PRO KIT

- OPT. VACUUM

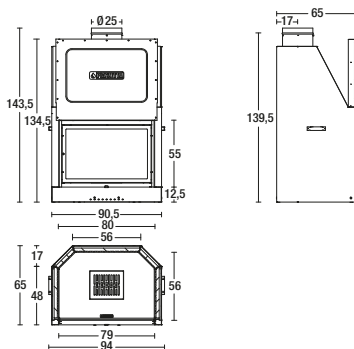

Model: MA 261 SL

Rivestimenti disponibili - Available surrounds P.244

# MA 262 SL



<b>Type</b> MA 262 SL	<b>kW Nom.</b> 13,0
<b>%</b> 75,0	<b>m<sup>3</sup></b> 220 - 375
<b>kg/h</b> 3,9	<b>cm</b> 25
<b>kg</b> 235	<b>cm (WxDxH)</b> 108x48x151

- STEEL
- ALUKER FIREBOX CAST-IRON BRAZIER
- RISE N'FALL DOOR
- ASH BOX
- MANUAL DAMPER FLUE
- OPT. EXT. AIR KIT
- OPT. ADJUST. FEET
- OPT. LEVELLING FEET
- OPT. LOG RETAINER
- OPT. VACUUM

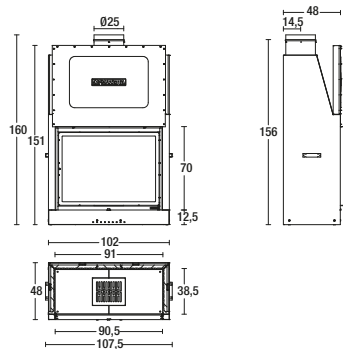

Model: MA 262 SL

Rivestimenti disponibili - Available surrounds P.244

# MA 263 SL



	<b>Type</b> MA 263 SL		<b>kW Nom.</b> 13,0
	<b>%</b> 75,0		<b>m<sup>3</sup></b> 220 - 375
	<b>kg/h</b> 3,9		<b>cm</b> 25
	<b>kg</b> 205		<b>cm (WxDxH)</b> 108x48x125

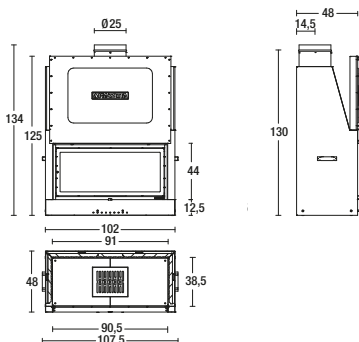

Model: MA 263 SL

Rivestimenti disponibili - Available surrounds P.244

# MA 263 B SL



	<b>Type</b> MA 263 B SL		<b>kW Nom.</b> 12,5
	<b>%</b> 73,0		<b>m<sup>3</sup></b> 210 - 360
	<b>kg/h</b> 4,0		<b>cm</b> 20
	<b>kg</b> 190		<b>cm (WxDxH)</b> 107x48x126

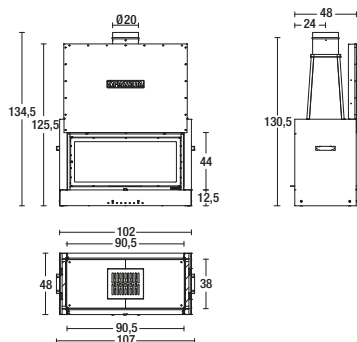
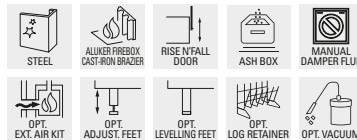

Model: MA 263 B SL

Rivestimenti disponibili - Available surrounds P.244

# MA 264 SL



	<b>Type</b> MA 264 SL		<b>kW Nom.</b> 14,5
	<b>%</b> 76,0		<b>m<sup>3</sup></b> 245 - 415
	<b>kg/h</b> 4,4		<b>cm</b> 25
	<b>kg</b> 263		<b>cm (WxDxH)</b> 136x48x130

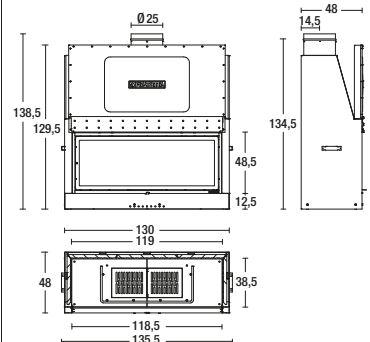

Model: MA 264 SL

Rivestimenti disponibili - Available surrounds P.244

# MA 265 SL



	<b>Type</b> MA 265 SL		<b>kW Nom.</b> 15,5
	<b>%</b> 75,0		<b>m<sup>3</sup></b> 260 - 445
	<b>kg/h</b> 4,8		<b>cm</b> 25
	<b>kg</b> 341		<b>cm (WxDxH)</b> 162x48x123

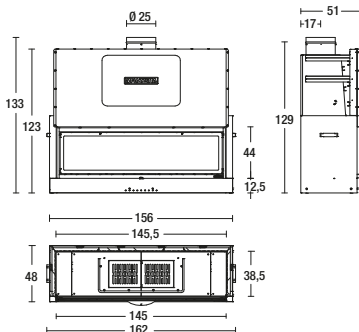

Model: MA 265 SL

Rivestimenti disponibili - Available surrounds P.244

# MA 266 SL



	<b>Type</b> MA 266 SL		<b>kW Nom.</b> 12,5
	<b>%</b> 75,0		<b>m<sup>3</sup></b> 210 - 360
	<b>kg/h</b> 3,9		<b>cm</b> 20
	<b>kg</b> 210		<b>cm (WxDxH)</b> 65x48x179

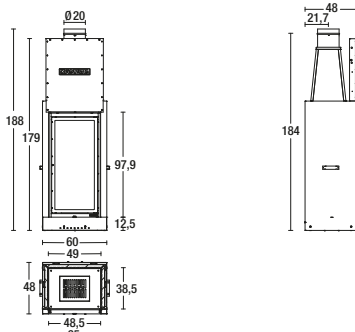

Model: MA 266 SL

Rivestimenti disponibili - Available surrounds P.244

# MA 267 SL



	<b>Type</b> MA 267 SL		<b>kW Nom.</b> 13,0
	<b>%</b> 76,3		<b>m<sup>3</sup></b> 220 - 375
	<b>kg/h</b> 4,0		<b>cm</b> 20
	<b>kg</b> 185		<b>cm (WxDxH)</b> 82x48x143

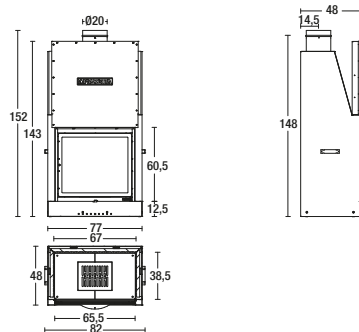

Model: MA 267 SL

Rivestimenti disponibili - Available surrounds P.244



# MA 270 SL



<b>Type</b> MA 270 SL	<b>kW Nom.</b> 13,5
<b>%</b> 70,0	<b>m<sup>3</sup></b> 225 - 390
<b>kg/h</b> 4,4	<b>cm</b> 25
<b>kg</b> 220	<b>cm (WxDxH)</b> 91x69x134

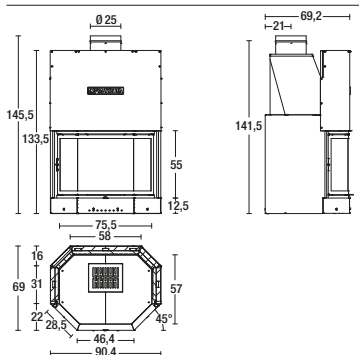

Model: MA 270 SL

Rivestimenti disponibili - Available surrounds P.244

# MA 271 SL



<b>Type</b> MA 271 SL	<b>kW Nom.</b> 13,4
<b>%</b> 63,0	<b>m<sup>3</sup></b> 225 - 385
<b>kg/h</b> 4,8	<b>cm</b> 25
<b>kg</b> 265	<b>cm (WxDxH)</b> 97x60x128

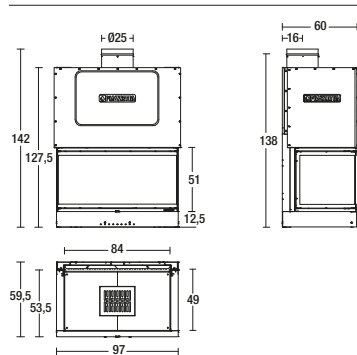
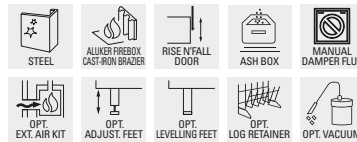

Model: MA 271 SL

Rivestimenti disponibili - Available surrounds P.245

# MA 272 SL



<b>Type</b> MA 272 SL	<b>kW Nom.</b> 14,5
<b>%</b> 63,0	<b>m<sup>3</sup></b> 245 - 415
<b>kg/h</b> 5,3	<b>cm</b> 25
<b>kg</b> 295	<b>cm (WxDxH)</b> 102x59x128

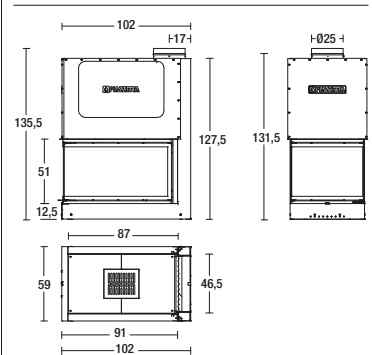

Model: MA 272 SL

Rivestimenti disponibili - Available surrounds P.245

# MA 274 SL



	<b>Type</b> MA 274 SL		<b>kW Nom.</b> 13,5
	<b>%</b> 70,0		<b>m³</b> 225 - 390
	<b>kg/h</b> 4,5		<b>cm</b> 20
	<b>kg</b> 235		<b>cm (WxDxH)</b> 59x70x128

- STEEL
- ALUKER FIREBOX CAST-IRON BRAZIER
- RISE N'FALL DOOR
- ASH BOX
- MANUAL DAMPER FLUE
- OPT. EXT. AIR KIT
- OPT. ADJUST. FEET
- OPT. LEVELLING FEET
- OPT. LOG RETAINER
- OPT. VACUUM

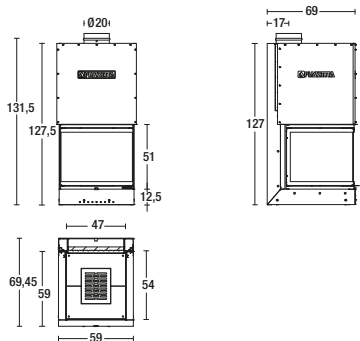

Model: MA 274 SL

# MA 280 D/S SL



	<b>Type</b> MA 280 SL (DX/SX)		<b>kW Nom.</b> 12,5
	<b>%</b> 73,0		<b>m³</b> 210 - 360
	<b>kg/h</b> 3,6		<b>cm</b> 20
	<b>kg</b> 160		<b>cm (WxDxH)</b> 82x50x125

- STEEL
- ALUKER FIREBOX CAST-IRON BRAZIER
- RISE N'FALL DOOR
- ASH BOX
- MANUAL DAMPER FLUE
- OPT. EXT. AIR KIT
- OPT. ADJUST. FEET
- OPT. LEVELLING FEET
- OPT. LOG RETAINER
- OPT. COOKING PRO KIT
- OPT. VACUUM

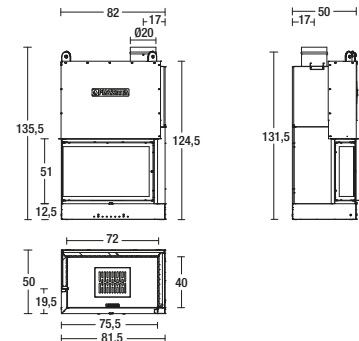

Model: MA 280 DX SL - MA 280 SX SL

# MA 281 D/S SL



	<b>Type</b> MA 281 SL (DX/SX)		<b>kW Nom.</b> 13,5
	<b>%</b> 76,0		<b>m³</b> 225 - 390
	<b>kg/h</b> 3,8		<b>cm</b> 25
	<b>kg</b> 182		<b>cm (WxDxH)</b> 92x58x125

- STEEL
- ALUKER FIREBOX CAST-IRON BRAZIER
- RISE N'FALL DOOR
- ASH BOX
- MANUAL DAMPER FLUE
- OPT. EXT. AIR KIT
- OPT. ADJUST. FEET
- OPT. LEVELLING FEET
- OPT. LOG RETAINER
- OPT. COOKING PRO KIT
- OPT. VACUUM

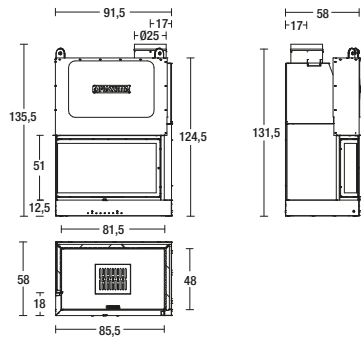

Model: MA 281 DX SL - MA 281 SX SL

Rivestimenti disponibili - Available surrounds P.245

# MA 283 D/S SL



	<b>Type</b> MA283SL-01		<b>kW Nom.</b> 13,5
	<b>%</b> 75,0		<b>m<sup>3</sup></b> 225 - 390
	<b>kg/h</b> 4,1		<b>cm</b> 25
	<b>kg</b> 185		<b>cm (WxDxH)</b> 96x58x128

- |  |  |  |  |  |
|--|--|--|--|--|
|  |  |  |  |  |
|  |  |  |  |  |

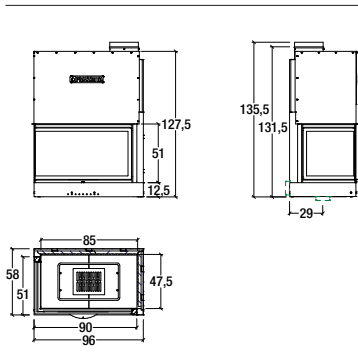

Model: MA 283 DX SL - MA 283 SX SL

# MA 284 SL



	<b>Type</b> MA 284 SL		<b>kW Nom.</b> 12,5
	<b>%</b> 73,5		<b>m<sup>3</sup></b> 210 - 360
	<b>kg/h</b> 4,0		<b>cm</b> 20
	<b>kg</b> 190		<b>cm (WxDxH)</b> 66x66x128

- |  |  |  |  |  |
|--|--|--|--|--|
|  |  |  |  |  |
|  |  |  |  |  |

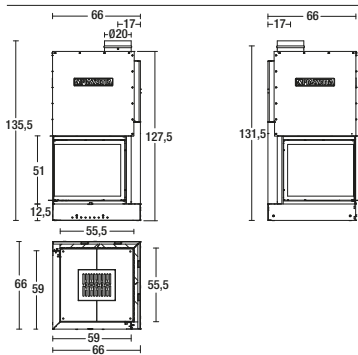

Model: MA 284 SL

# MA 285 D/S SL



	<b>Type</b> MA 285 SL		<b>kW Nom.</b> 12,5
	<b>%</b> 72,5		<b>m<sup>3</sup></b> 210 - 360
	<b>kg/h</b> 4,1		<b>cm</b> 20
	<b>kg</b> 185		<b>cm (WxDxH)</b> 82x50x128

- |  |  |  |  |  |
|--|--|--|--|--|
|  |  |  |  |  |
|  |  |  |  |  |

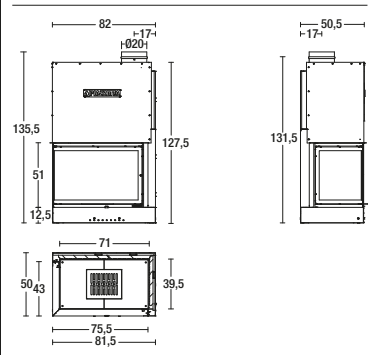

Model: MA 285 SL

Rivestimenti disponibili - Available surrounds P.245

# MA



MA 260 con vetro  
with glass



## FOCOLARI IN ACCIAIO

La struttura in acciaio e il piano fuoco in ghisa di grandi dimensioni conferiscono al focolare solidità, robustezza e durata nel tempo che contraddistinguono da sempre i prodotti Piazzetta. Di semplice installazione, riscalda per irraggiamento e convezione naturale. Può essere dotato di un kit cottura e di un kit con anta in vetro ceramico.

### EN Steel fireboxes

The steel structure and large-size cast iron hearth ensure sturdiness and long-lasting operation, which have always distinguished Piazzetta products. Easy to install, they heat through radiation and natural convection. Can be equipped with a cooking kit or a kit with ceramic glass door.

### FR Monoblocs en acier

La structure en acier et la sole foyer en fonte de grandes dimensions confèrent au monobloc la solidité, la robustesse et la durabilité qui distinguent depuis toujours les produits Piazzetta. Simple à installer, il chauffe par rayonnement et convection naturelle et peut être doté d'un kit de cuisson et d'une porte en verre céramique.

### DE Heizeinsätze aus stahl

Die Konstruktion aus Stahl und der große Feuertisch aus Gusseisen verleihen dem Heizeinsatz Solidität, Robustheit und hohe Lebensdauer, seit jeher Kennzeichen der Piazzetta Produkte. Einfache Installation, Heizung durch Strahlungswärme und Naturkonvektion. Kann mit Cooking-Pro Set und Tür aus Keramikglas versehen werden.

### ES Monobloques de acero

La estructura de acero y el plano del fuego de hierro fundido de amplio tamaño le dan al monobloque la solidez, resistencia y durabilidad que caracterizan desde siempre los productos Piazzetta. Instalación sencilla y calefacción por radiación y convección natural. Puede contar con kit de cocción y kit con puerta de vidrio cerámico.



	Type MA 260		kW Nom. 8,0
	% 59,0		m <sup>3</sup> 135 - 230
	kg/h 3,2		cm 20
	kg 135		cm (WxDxH) 80x53x120

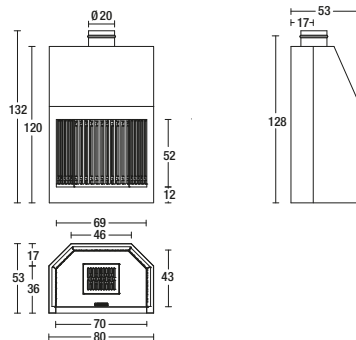

Model: MA 260 ANTA

Rivestimenti disponibili - Available surrounds P.245



PIAZZETTA

# MA 260 senza vetro without glass



	<b>Type</b> MA 260		<b>NOM. kW</b> 8,0
	<b>%</b> 51,0		<b>m<sup>3</sup></b> 135 - 230
	<b>kg/h</b> 3,6		<b>cm</b> 20
	<b>kg</b> 120		<b>cm (WxDxH)</b> 80x53x120

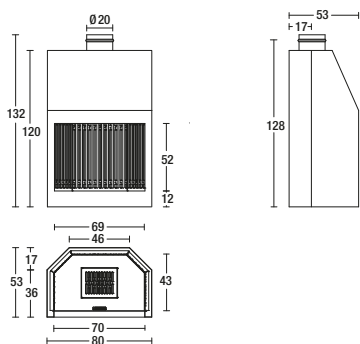
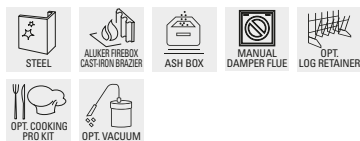

Model: MA 260

Rivestimenti disponibili - Available surrounds P.245

# MA 261 con vetro with glass



	<b>Type</b> MA 261		<b>NOM. kW</b> 9,0
	<b>%</b> 59,0		<b>m<sup>3</sup></b> 150 - 260
	<b>kg/h</b> 3,4		<b>cm</b> 25
	<b>kg</b> 172		<b>cm (WxDxH)</b> 90x65x128

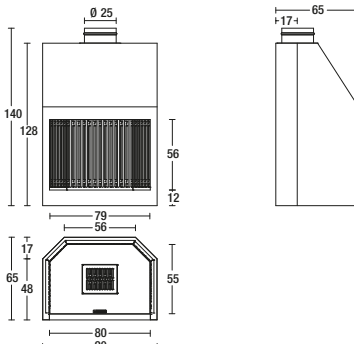

Model: MA 261 ANTA

Rivestimenti disponibili - Available surrounds P.245

# MA 261 senza vetro without glass



	<b>Type</b> MA 261		<b>NOM. kW</b> 9,0
	<b>%</b> 52,5		<b>m<sup>3</sup></b> 150 - 260
	<b>kg/h</b> 4,0		<b>cm</b> 25
	<b>kg</b> 155		<b>cm (WxDxH)</b> 90x65x128

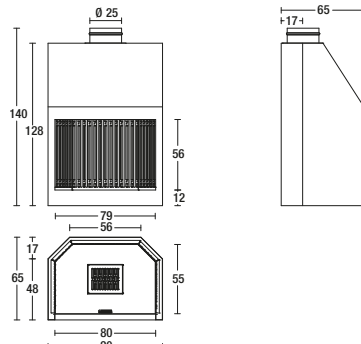
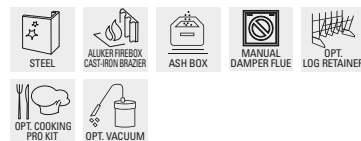

Model: MA 261

Rivestimenti disponibili - Available surrounds P.245

MA 280 D/S con vetro  
with glass



<b>Type</b> MA 280 (DX/SX)	<b>NOM. kW Nom.</b> 6,5
<b>%</b> 55,5	<b>m<sup>3</sup></b> 110 - 190
<b>kg/h</b> 2,7	<b>cm</b> 20
<b>kg</b> 135	<b>cm (WxDxH)</b> 81x50x120

MA 280 D/S senza vetro  
without glass



<b>Type</b> MA 280 (DX/SX)	<b>NOM. kW Nom.</b> 7,0
<b>%</b> 51,5	<b>m<sup>3</sup></b> 120 - 200
<b>kg/h</b> 3,2	<b>cm</b> 20
<b>kg</b> 115	<b>cm (WxDxH)</b> 81x50x120

MA 281 D/S con vetro  
with glass



<b>Type</b> MA 281 (DX/SX)	<b>NOM. kW Nom.</b> 7,0
<b>%</b> 57,0	<b>m<sup>3</sup></b> 120 - 200
<b>kg/h</b> 3,0	<b>cm</b> 25
<b>kg</b> 160	<b>cm (WxDxH)</b> 91x58x120

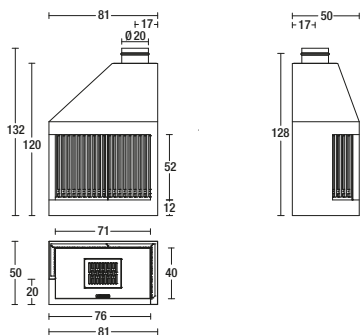
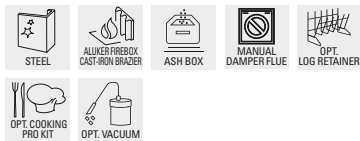

Model: MA 280 DX ANTA / MA 280 SX ANTA

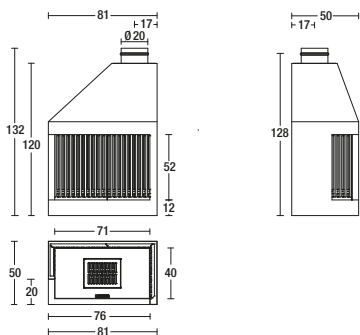

Model: MA 280 DX / MA 280 SX

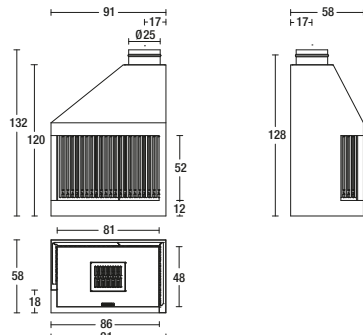

Model: MA 281 DX ANTA / MA 281 SX ANTA

**MA 281 D/S** senza vetro  
without glass



<b>E</b> ENERGY EFFIC. CLASS	<b>Type MA 281 (DX/SX)</b>	<b>NOM. kW 7,0</b> HEAT OUTPUT
<b>% 51,0</b>	<b>m<sup>3</sup> 120 - 200</b> HEATING CAPACITY	
<b>kg/h 3,2</b>	<b>cm 25</b> FLUE DIAM.	
<b>kg 140</b> WEIGHT	<b>cm (WxDxH) 91x58x120</b> DIMENSIONS	

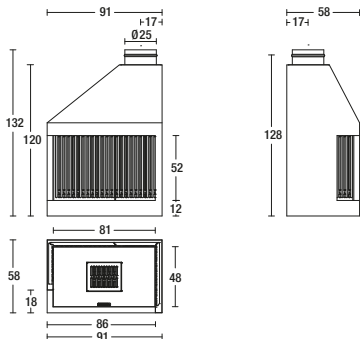
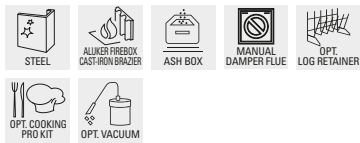

Model: MA 281 DX / MA 281 SX

**MA 282 D/S** con vetro  
with glass



<b>D</b> ENERGY EFFIC. CLASS	<b>Type MA 281 (DX/SX)</b>	<b>NOM. kW 7,0</b> HEAT OUTPUT
<b>% 57,0</b>	<b>m<sup>3</sup> 120 - 200</b> HEATING CAPACITY	
<b>kg/h 3,0</b>	<b>cm 25</b> FLUE DIAM.	
<b>kg 190</b> WEIGHT	<b>cm (WxDxH) 91x70x120</b> DIMENSIONS	

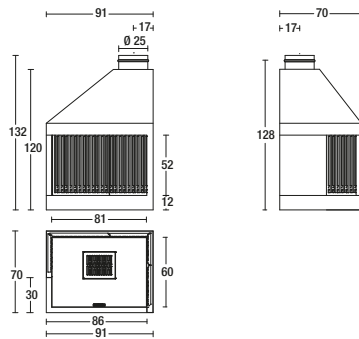

Model: MA 282 DX ANTA / MA 282 SX ANTA

**MA 282 D/S** senza vetro  
without glass



<b>E</b> ENERGY EFFIC. CLASS	<b>Type MA 281 (DX/SX)</b>	<b>NOM. kW 7,0</b> HEAT OUTPUT
<b>% 51,0</b>	<b>m<sup>3</sup> 120 - 200</b> HEATING CAPACITY	
<b>kg/h 3,2</b>	<b>cm 25</b> FLUE DIAM.	
<b>kg 165</b> WEIGHT	<b>cm (WxDxH) 91x70x120</b> DIMENSIONS	

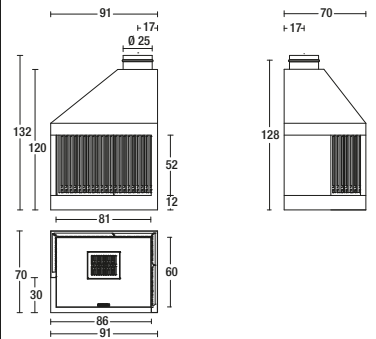
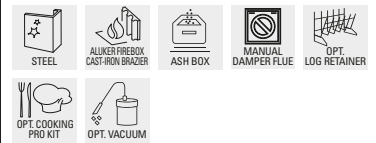

Model: MA 282 DX / MA 282 SX

# HT



## HT 600



### FOCOLARI HIGH TECHNOLOGY

In un perfetto mix di tecnologia, con l'impiego di un focolare in Aluker® e ghisa, e l'utilizzo di acciaio di notevole spessore, i focolari HT offrono rendimenti elevati, ottime prestazioni e una lunga durata nel tempo. L'apertura dell'anta è a saliscendi e l'ampia superficie vetrata assicura una piacevole visione del fuoco.

### EN High-technology fireboxes

A perfect mix of technology, featuring the Aluker® and cast iron firebox, and high-thickness steel, the HT fireboxes ensure high yields, excellent performance and long-lasting operation. The door opens vertically and the broad glass surface guarantees a pleasant view of the fire.

### DE Hi-tech-heizeinsätze

In einer perfekten Mischung aus Technologie, bei Einsatz eines Feuerraums aus Aluker® und Gusseisen, und der Verwendung von dickwandigem Stahl bieten die Heizeinsätze HT hohe Wirkungsgrade, optimale Leistungen und lange Lebensdauer. Die Tür mit Hebe-/Senksystem und die große Glasscheibe sorgen für eine angenehme Sicht auf das Feuer.

### FR Monoblocs high technology

Caractérisés par un mélange parfait de technologie qui réunit foyer en Aluker® et fonte, et acier de forte épaisseur, les monoblocs HT offrent des rendements élevés, d'excellentes performances et une longue durée de vie. L'ouverture de la porte est verticale et la grande surface vitrée assure une agréable vision du feu.

### ES Monobloques high technology

En una combinación perfecta de tecnología con el uso de un hogar de Aluker® y hierro fundido y el uso de acero de gran espesor, los monobloques HT ofrecen rendimientos elevados, óptimas prestaciones y gran durabilidad. La apertura con puerta corredera vertical y la amplia superficie de vidrio aseguran una agradable vista del fuego.



Type  
600



%  
74,0



kg/h  
3,5



kg  
190



kW Nom.  
10,0



m<sup>3</sup>  
170 - 290



cm  
20



cm (WxDxH)  
84x55x154

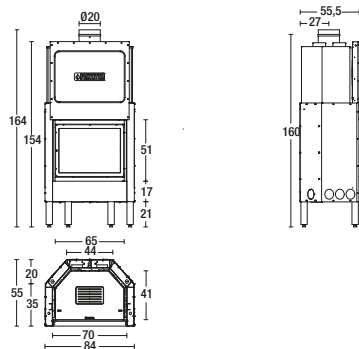

Model: 600 HT



Rivestimenti disponibili - Available surrounds P.245



# HT 610



<b>Type 610</b> ENERGY EFFIC. CLASS	<b>NOM. kW Nom. 12,5</b> HEAT OUTPUT
<b>% 75,0</b> THERMAL EFFICIENCY	<b>m<sup>3</sup> 210 - 360</b> HEATING CAPACITY
<b>kg/h 4,0</b> CONSUMPTION	<b>cm 25</b> FLUE DIAM.
<b>kg 200</b> WEIGHT	<b>cm (WxDxH) 93x59x160</b> DIMENSIONS

- |  |  |  |  |  |
|--|--|--|--|--|
|  |  |  |  |  |
|  |  |  |  |  |

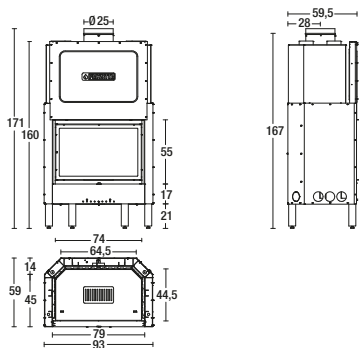

Model: 610 HT/B

Rivestimenti disponibili - Available surrounds P.245

# HT 650



<b>Type 650</b> ENERGY EFFIC. CLASS	<b>NOM. kW Nom. 8,0</b> HEAT OUTPUT
<b>% 72,5</b> THERMAL EFFICIENCY	<b>m<sup>3</sup> 135 - 230</b> HEATING CAPACITY
<b>kg/h 2,9</b> CONSUMPTION	<b>cm 20</b> FLUE DIAM.
<b>kg 190</b> WEIGHT	<b>cm (WxDxH) 67x43x163</b> DIMENSIONS

- |  |  |  |  |  |
|--|--|--|--|--|
|  |  |  |  |  |
|  |  |  |  |  |

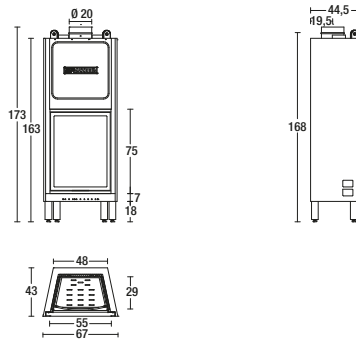

Model: 650 HT

Rivestimenti disponibili - Available surrounds P.245

# HT 700



<b>Type 700</b> ENERGY EFFIC. CLASS	<b>NOM. kW Nom. 10,5</b> HEAT OUTPUT
<b>% 72,0</b> THERMAL EFFICIENCY	<b>m<sup>3</sup> 175 - 300</b> HEATING CAPACITY
<b>kg/h 3,4</b> CONSUMPTION	<b>cm 20</b> FLUE DIAM.
<b>kg 195</b> WEIGHT	<b>cm (WxDxH) 86x57x155</b> DIMENSIONS

- |  |  |  |  |  |
|--|--|--|--|--|
|  |  |  |  |  |
|  |  |  |  |  |

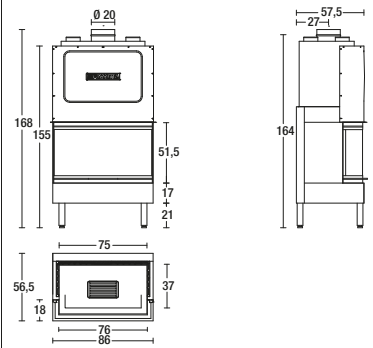

Model: 700 HT/B

Rivestimenti disponibili - Available surrounds P.245

# HT 750



	<b>Type</b> 750		<b>kW Nom.</b> 11,0
	<b>%</b> 75,0		<b>m<sup>3</sup></b> 185 - 315
	<b>kg/h</b> 3,5		<b>cm</b> 20
	<b>kg</b> 170		<b>cm (WxDxH)</b> 85x56x158

- STEEL
- ALUKER FIREBOX CAST-IRON BRAZIER
- RISE N'FALL DOOR
- ASH BOX
- MANUAL DAMPER FLUE
- OPT. MULTIFLUO DUCTING
- OPT. MULTIFLUO+ DUCTING
- EXT. AIR KIT
- OPT. VACUUM
- OPT. LOG RETAINER

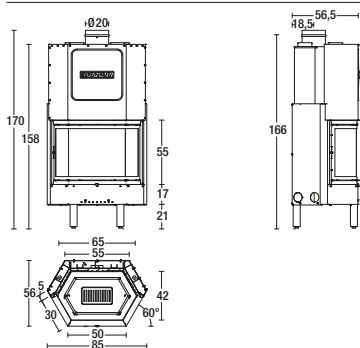

Model: 750 HT/B

# HT 760 T



	<b>Type</b> 760T		<b>kW Nom.</b> 14,0
	<b>%</b> 75,5		<b>m<sup>3</sup></b> 235 - 400
	<b>kg/h</b> 4,0		<b>cm</b> 20
	<b>kg</b> 252		<b>cm (WxDxH)</b> 83x65x182

- STEEL
- ALUKER FIREBOX CAST-IRON BRAZIER
- RISE N'FALL DOOR
- ASH BOX
- MANUAL DAMPER FLUE
- OPT. MULTIFLUO DUCTING
- OPT. MULTIFLUO+ DUCTING
- OPT. EXT. AIR KIT
- OPT. VACUUM
- OPT. LOG RETAINER

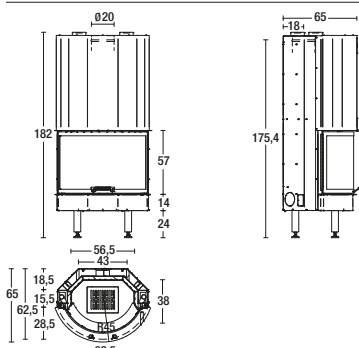

Model: 760T

Rivestimenti disponibili - Available surrounds P.245

# HT 801 D/S



	<b>Type</b> 801		<b>kW Nom.</b> 11,5
	<b>%</b> 71,2		<b>m<sup>3</sup></b> 195 - 330
	<b>kg/h</b> 3,2		<b>cm</b> 20
	<b>kg</b> 230		<b>cm (WxDxH)</b> 93x57x150

- STEEL
- ALUKER FIREBOX CAST-IRON BRAZIER
- RISE N'FALL DOOR
- ASH BOX
- MANUAL DAMPER FLUE
- OPT. MULTIFLUO DUCTING
- OPT. MULTIFLUO+ DUCTING
- OPT. EXT. AIR KIT
- OPT. VACUUM
- OPT. LOG RETAINER

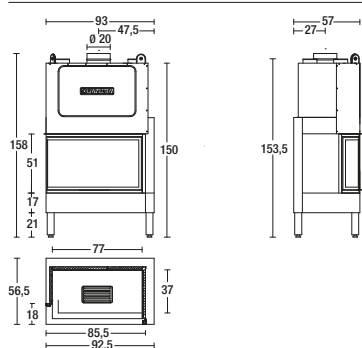

Model: 801 HT/A

# HT 810 D/S



<b>Type 801</b>	<b>kW Nom. 11,5</b>
<b>% 71,2</b>	<b>m³ 195 - 330</b>
<b>kg/h 3,2</b>	<b>cm 20</b>
<b>kg 195</b>	<b>cm (WxDxH) 76x50x150</b>

- STEEL
- ALUKER FIREBOX CAST-IRON BRAZER
- RISE N'FALL DOOR
- ASH BOX
- MANUAL DAMPER FLUE
- OPT. MULTIFUOCO DUCTING
- OPT. MULTIFUOCO+ DUCTING
- OPT. EXT. AIR KIT
- OPT. VACUUM
- OPT. LOG RETAINER

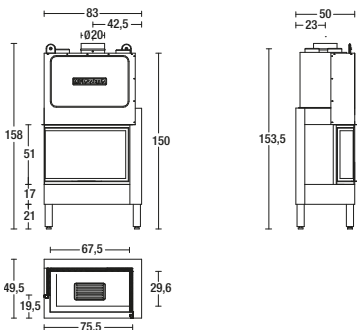

Model: 810 HT/A

# HT 2010B



<b>Type 2010</b>	<b>kW Nom. 14,0</b>
<b>% 73,0</b>	<b>m³ 235 - 400</b>
<b>kg/h 4,4</b>	<b>cm 25</b>
<b>kg 200</b>	<b>cm (WxDxH) 95x60x160</b>

- STEEL
- ALUKER FIREBOX CAST-IRON BRAZER
- RISE N'FALL DOOR
- ASH BOX
- MANUAL DAMPER FLUE
- OPT. MULTIFUOCO DUCTING
- OPT. MULTIFUOCO+ DUCTING
- OPT. EXT. AIR KIT
- OPT. VACUUM
- OPT. LOG RETAINER

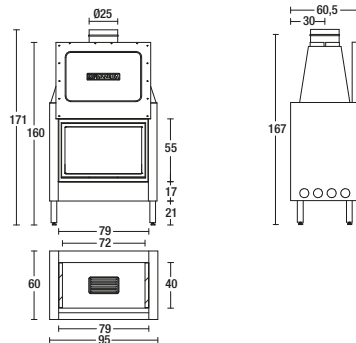

Model: 2010 HT/B

Rivestimenti disponibili - Available surrounds P.245

# HT 510 SL



<b>Type 510</b>	<b>kW Nom. 8,0</b>
<b>% 82,0</b>	<b>m³ 135 - 230</b>
<b>kg/h 2,3</b>	<b>cm 18</b>
<b>kg 180</b>	<b>cm (WxDxH) 50x50x154</b>

- STEEL
- ALUKER FIREBOX CAST-IRON BRAZER
- RISE N'FALL DOOR
- ASH BOX
- OPT. MANUAL DAMPER FLUE
- ADJUST. FLUE CONNECTOR
- OPT. MULTIFUOCO DUCTING
- OPT. MULTIFUOCO+ DUCTING
- OPT. EXT. AIR KIT
- OPT. VACUUM

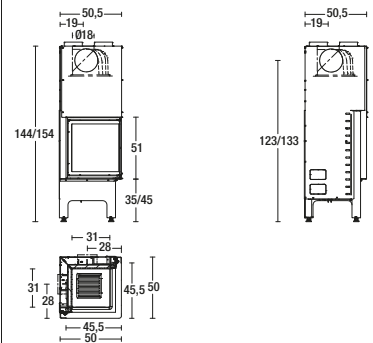

Model: 510 SL

# HT 555T SL



<b>Energy Effic. Class</b>	<b>Type 555</b>	<b>Heat Output</b>	<b>kW Nom. 8,0</b>
<b>Thermal Efficiency</b>	<b>% 81,0</b>	<b>Heating Capacity</b>	<b>m<sup>3</sup> 135 - 230</b>
<b>Consumption</b>	<b>kg/h 2,3</b>	<b>Flue Diam.</b>	<b>cm 18</b>
<b>Weight</b>	<b>kg 185</b>	<b>Dimensions</b>	<b>cm (WxDxH) 61x54x154</b>

<b>STEEL</b>	<b>ALUKER FIREBOX CAST-IRON BRAZIER</b>	<b>RISE N'TALL DOOR</b>	<b>ASH BOX</b>	<b>OPT. MANUAL DAMPER FLUE</b>
<b>ADJUST. FLUE CONNECTOR</b>	<b>OPT. MULTIFLUE DUCTING</b>	<b>OPT. MULTIFLUE DUCTING</b>	<b>OPT. EXT. AIR KIT</b>	<b>OPT. VACUUM</b>

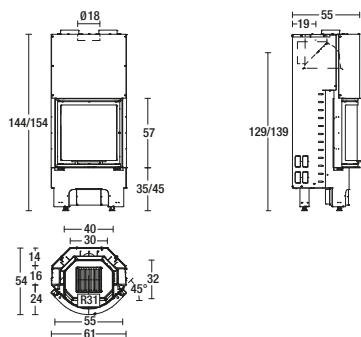

Model: 555T SL

Rivestimenti disponibili - Available surrounds P.245



# Cottura

I prodotti della linea cottura forniscono soluzioni di grande utilità per una cucina speciale, quella con il fuoco a legna. Si possono così ottenere gustosissimi piatti preparati nel forno, su un piano in ghisa o direttamente sulla fiamma. Oltre ai forni tradizionali è disponibile anche una cucina a legna predisposta per l'incasso.

## EN Cooking

The products of the cooking range are highly suited to special cookers – those with a wood fire. You can cook savoury dishes on a cast iron plate or directly over the flame. Besides traditional ovens, there is also the wood-burning cooker designed for built-in installation.

## FR Cuisson

Les produits de la ligne Cuisson offrent des solutions très utiles pour une cuisine très spéciale : la cuisine au feu de bois. Dégustez des plats très savoureux préparés dans le four, sur un plan de cuisson en fonte ou directement sur la flamme. Outre les fours traditionnels, Piazzetta propose aussi une cuisinière à bois encastrable.

## DE Zubereitung von Speisen

Die Produkte zur Speisenzubereitung bieten zweckmäßige Lösungen für eine besondere Küche, die Holzfeuerküche. So können schmackhafte Gerichte im Backofen, auf einer gusseisernen Platte oder direkt auf dem Feuer zubereitet werden. Neben den herkömmlichen Backöfen ist auch ein Einbaugerät mit Holzfeuerung erhältlich.

## ES Cocción

Los productos de la línea de cocción ofrecen soluciones de gran utilidad para una cocina especial; aquella con fuego de leña. Se pueden obtener exquisitos platos preparados en el horno, en una placa de hierro fundido o directamente sobre la llama. Además de los hornos tradicionales hay disponible una cocina de leña empotrable.

## CHEF 72

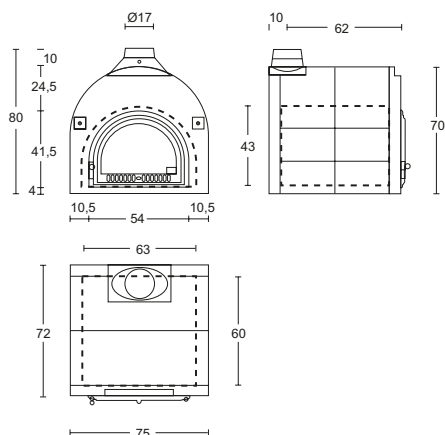

kg  
300

WEIGHT



cm (WxDxH)  
75x72x80

COOKING AREA



cm  
17

FLUE DIAM.



Standard

THERMOMETER



MANUAL DAMPER FLUE

# CHEF 102

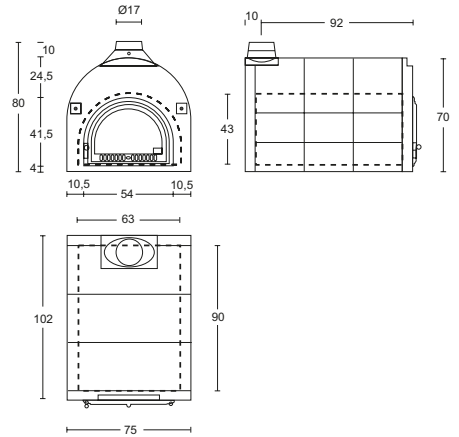

kg  
400



cm (WxDxH)  
75x102x80



cm  
17



Standard



MANUAL  
DAMPER FLUE

# CARLOTTA

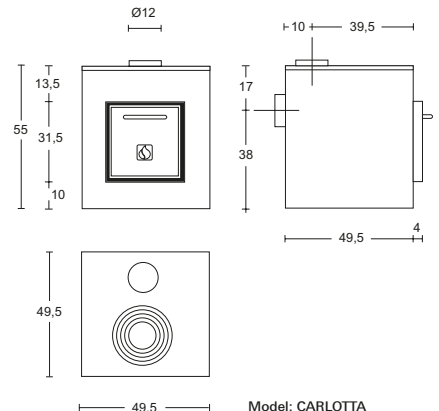

Type  
**CARLOTTA**



%  
73,8



kW Nom.  
6,0



cm  
12



kg  
60



ALUKER



OPT REAR  
FLUE OUTLET



TOP FLUE  
OUTLET



COOKING PLATE  
CAST-IRON



STEEL



ASH BOX

- \* Con collarino optional
- \* With optional flue collar
- \* Avec rosace en option
- \* Mit optionalen Rauchstutzen
- \* Con collarin opcional

Model: CARLOTTA

# IL



## IL 52/57 M



### INSERTI A LEGNA

Gli inserti a legna IL sono appositamente sviluppati per essere installati in caminetti tradizionali già esistenti, migliorandone prestazioni e sicurezza e più pratico l'utilizzo. Sono ideali anche per prime installazioni. La geometria del flusso calibrato per l'aria primaria e il doppio sistema per l'aria terziaria ottimizzano i rendimenti.

#### EN Wood-burning inserts

IL wood-burning inserts can be installed in existing traditional fireplaces, where they improve the latter's performance and safety and make them more practical. They are also ideal for first-time installation. The geometry of the calibrated flow for primary air and the dual system for tertiary air optimise the performances.

#### FR Inserts à bois

Spécialement conçus pour être installés dans les cheminées existantes, les inserts à bois en améliorent les performances, la sécurité et rendent leur utilisation plus pratique. Ils sont aussi parfaits pour une première installation. Les rendements sont optimisés par la géométrie du flux d'air primaire et le double système d'air tertiaire.

#### DE Holz-kamineinsätze

Die Holz-Einsätze der Baureihe IL wurden speziell für den Einbau in bestehende herkömmliche Kamine entwickelt, um deren Leistung und Sicherheit sowie praktische Nutzbarkeit zu erhöhen. Sie sind auch für Erstinstallationen ideal. Geometrie des kalibrierten Primärluftstroms und doppeltes System für Tertiärluft optimieren die Wirkungsgrade.

#### ES Hogares de leña

Los hogares de leña IL se han concebido para la instalación en chimeneas tradicionales ya existentes, para mejorar el desempeño y la seguridad y ofrecer un uso más práctico. Ideales también para primeras instalaciones. La forma del flujo calibrado para el aire primario y el doble sistema para el aire terciario optimizan el rendimiento.



	<b>Type</b> SL320-02		<b>kW Nom.</b> 9,0
	<b>%</b> 80,5		<b>m<sup>3</sup></b> 150 - 260
	<b>kg/h</b> 2,7		<b>cm</b> 15
	<b>kg</b> 96		<b>cm (WxDxH)</b> 51x43x57

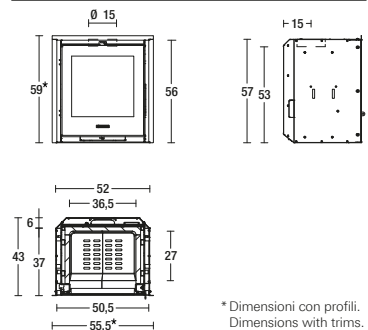

Model: IL 52/57

Rivestimenti disponibili - Available surrounds P.245



# IL 65/49



<b>Type</b> IL 65/49	<b>kW Nom.</b> 7,0
<b>%</b> 80,1	<b>m<sup>3</sup></b> 120 - 200
<b>kg/h</b> 1,9	<b>cm</b> 15
<b>kg</b> 105	<b>cm (WxDxH)</b> 64x43x49

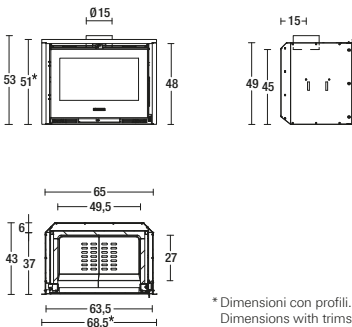

Model: IL 65/49

# IL 65/54



<b>Type</b> IL 65/54	<b>kW Nom.</b> 7,0
<b>%</b> 78,1	<b>m<sup>3</sup></b> 120 - 200
<b>kg/h</b> 2,0	<b>cm</b> 15
<b>kg</b> 110	<b>cm (WxDxH)</b> 64x43x54

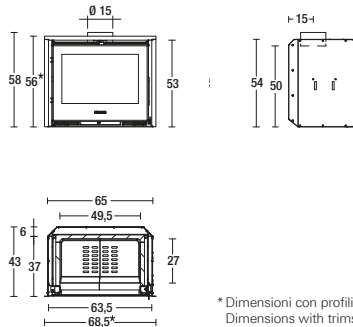

Model: IL 65/54

# IL 65/56 V



<b>Type</b> IL 65/56 V	<b>kW Nom.</b> 7,0
<b>%</b> 80,0	<b>m<sup>3</sup></b> 120 - 200
<b>kg/h</b> 1,9	<b>cm</b> 15
<b>kg</b> 120	<b>cm (WxDxH)</b> 64x43x56

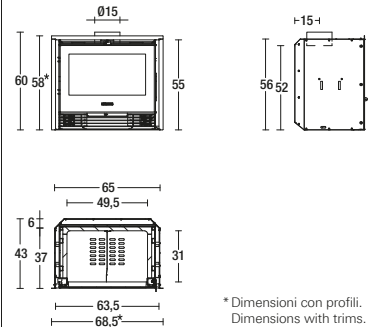

Model: IL 65/56 V

# IL 75/58



	<b>Type</b> IL 75/58		<b>kW Nom.</b> 9,0
	<b>%</b> 80,0		<b>m<sup>3</sup></b> 150 - 260
	<b>kg/h</b> 2,4		<b>cm</b> 18
	<b>kg</b> 125		<b>cm (WxDxH)</b> 74x43x58

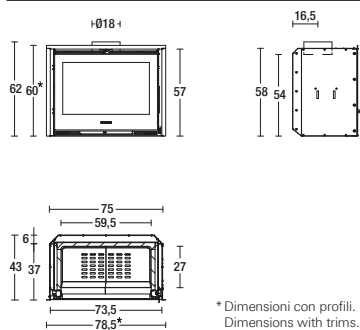

\* Dimensioni con profili.  
Dimensions with trims.

Model: IL 75/58

# IL 75/64



	<b>Type</b> IL 75/64		<b>kW Nom.</b> 9,0
	<b>%</b> 79,7		<b>m<sup>3</sup></b> 150 - 260
	<b>kg/h</b> 2,4		<b>cm</b> 18
	<b>kg</b> 132		<b>cm (WxDxH)</b> 74x43x64

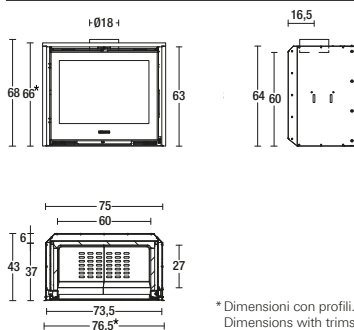

\* Dimensioni con profili.  
Dimensions with trims.

Model: IL 75/64

# IL 75/66 V



	<b>Type</b> IL 75/66 V		<b>kW Nom.</b> 9,0
	<b>%</b> 80,0		<b>m<sup>3</sup></b> 150 - 260
	<b>kg/h</b> 2,4		<b>cm</b> 18
	<b>kg</b> 147		<b>cm (WxDxH)</b> 74x43x66

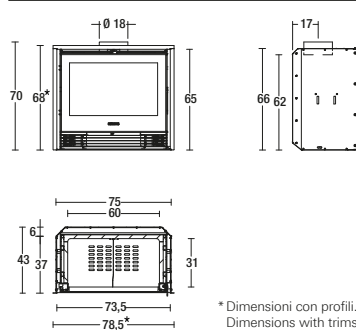

\* Dimensioni con profili.  
Dimensions with trims.

Model: IL 75/66 V



# MP



## MP 938



### FOCOLARI A PELLETT

Praticità, semplicità di impiego, facile manutenzione ed alti rendimenti caratterizzano e contraddistinguono i focolari a pellet MP.

Il design è lineare e la particolare costruzione garantisce una notevole flessibilità di installazione. Gli alti rendimenti, ed una ricca dotazione di serie, offrono innumerevoli possibilità di impiego.

#### EN Pellet-burning fireboxes

Practicality, ease of use, straightforward maintenance and high performances distinguish the MP pellet-burning fireboxes. Their linear profile and special design guarantee considerable installation flexibility. The MP range can be used in countless ways thanks to its high performances and rich assortment of standard features.

#### FR Monoblocs à granulés

Commodité, simplicité d'utilisation, entretien facile et hauts rendements sont les signes distinctifs des monoblocs à granulés MP. Le design linéaire et la fabrication particulière garantissent une grande souplesse d'installation. Avec ses hauts rendements et son excellent équipement de série, la série MP offre une foule de possibilités.

#### DE Pellet-heizeinsätze

Zweckmäßigkeit, einfache Bedienung und Wartung sowie hohe Wirkungsgrade zeichnen die Pellet-Heizeinsätze MP aus. Das Design ist linear, die spezielle Konstruktion bietet beträchtliche Installationsflexibilität. Hohe Wirkungsgrade und reichhaltige Serienausstattung bieten mit der Baureihe MP unzählige Einsatzmöglichkeiten.

#### ES Monobloques de pellets

Comodidad, sencillez de uso, fácil mantenimiento y alto rendimiento son las características de los monobloques de pellets MP. El diseño es lineal y la construcción especial garantiza una apreciable flexibilidad de instalación. Los altos rendimientos y una rica dotación de serie ofrecen incontables posibilidades de uso.



<b>Energy Effic. Class</b>	<b>Type P90</b>	<b>kW Nom.</b> 3,5 - 11,3
<b>Thermal Efficiency</b>	<b>% 89,2 - 90,0</b>	<b>Heating Capacity</b> m <sup>3</sup> 190 - 325
<b>Consumption</b>	<b>kg/h 0,8 - 2,6</b>	<b>Hopper Capacity</b> kg 30
<b>Level Power</b>	<b>5 l</b>	<b>Flue Diam.</b> cm 8
<b>Weight</b>	<b>kg 137</b>	<b>Dimensions</b> cm (WxDxH) 83x46x138

<b>MULTIWOOD DUCTING</b>	<b>DUAL POWER</b>	<b>MULTICOMFORT</b>	<b>STEEL</b>	<b>CAST-IRON FIREBOX</b>
<b>FUEL LEVEL SENSOR</b>	<b>ECO</b>	<b>ENERGY SAVING</b>	<b>HIGH AUTONOMY</b>	<b>OPT. PELLET LOADING KIT</b>
<b>OPT. REAR FLUE OUTLET</b>	<b>OPT. FLUE SIDE</b>	<b>OPT. EXT. AIR KIT</b>	<b>OPT. SMS-APP</b>	<b>OPT. VACUUM</b>

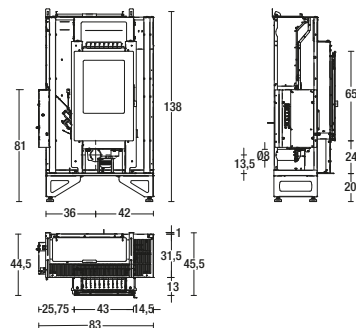

Model: MP938

Rivestimenti disponibili - Available surrounds P.245

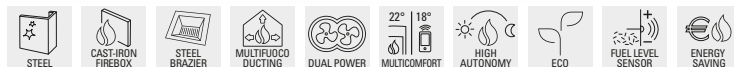

# MP 970



<b>Type P97</b>	<b>NOM. kW Nom.</b> 3,3 - 11,0 3,3 - 15,0
<b>%</b> 87,2 - 86,7 87,2 - 83,9	<b>m³</b> 185 - 315 250 - 430
<b>kg/h</b> 0,8 - 2,7 0,8 - 4,2	<b>kg</b> 60
<b>5 l</b>	<b>cm</b> 8
<b>kg</b> 180	<b>cm (WxDxH)</b> 76x65x139

MULTIFUECO DUCTING	DUAL POWER	22° 18° MULTICOMFORT	STEEL	CAST-IRON FIREBOX
FUEL LEVEL SENSOR	ECO	ENERGY SAVING	HIGH AUTONOMY	OPT. PELLET LOADING KIT
OPT. REAR FLUE OUTLET	OPT. FLUE SIDE	OPT. EXT. AIR KIT	OPT. SMS-APP	OPT. VACUUM

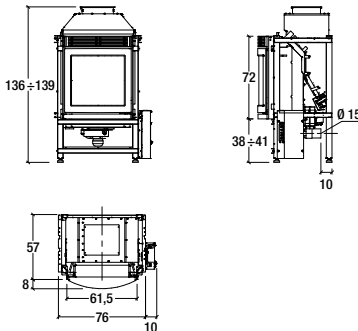

Model: MP970

# MP 973



<b>Type P97</b>	<b>NOM. kW Nom.</b> 3,3 - 11,0 3,3 - 15,0
<b>%</b> 87,2 - 86,7 87,2 - 83,9	<b>m³</b> 185 - 315 250 - 430
<b>kg/h</b> 0,8 - 2,7 0,8 - 4,2	<b>kg</b> 60
<b>5 l</b>	<b>cm</b> 8
<b>kg</b> 180	<b>cm (WxDxH)</b> 75x53x152

MULTIFUECO DUCTING	DUAL POWER	22° 18° MULTICOMFORT	STEEL	CAST-IRON FIREBOX
FUEL LEVEL SENSOR	ECO	ENERGY SAVING	HIGH AUTONOMY	OPT. PELLET LOADING KIT
OPT. REAR FLUE OUTLET	OPT. FLUE SIDE	OPT. EXT. AIR KIT	OPT. SMS-APP	OPT. VACUUM

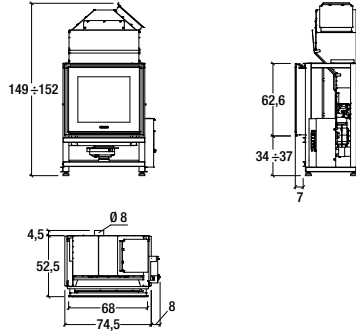

Model: MP973

Rivestimenti disponibili - Available surrounds P.245

# MP 980



<b>Type -</b>	<b>NOM. kW Nom.</b> 12,0
<b>%</b> 90,7	<b>m³</b> 200 - 345
<b>kg/h</b> 2,7	<b>kg</b> 20
<b>5 l</b>	<b>cm</b> 8
<b>kg</b> 180	<b>cm (WxDxH)</b> 72x65x156

MULTIFUECO DUCTING	DUAL POWER	22° 18° MULTICOMFORT	REMOTE CONTROL LCD	ALU-KER FIREBOX CAST-IRON BRAZER
FUEL LEVEL SENSOR	ENERGY SAVING	20° 22° 18° 20° PROGRAMMING	AUTOMATIC CLEANING	ROLLING FIREBOX
ASH TRAY	PELLET LOADING KIT	VACUUM	OPT. EXT. AIR KIT	OPT. SMS-APP

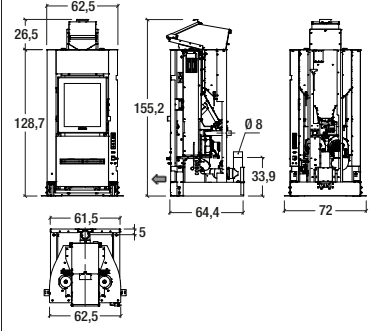

MP980 WF

Rivestimenti disponibili - Available surrounds P.245



<b>A+</b> ENERGY EFFIC. CLASS	Type -	<b>12,0</b> HEAT OUTPUT
<b>90,7</b> THERMAL EFFICIENCY		<b>200 - 354</b> HEATING CAPACITY
<b>2,7</b> CONSUMPTION		<b>20</b> HOPPER CAPACITY
<b>5 l</b> LEVEL POWER		<b>8</b> FLUE DIAM.
<b>180</b> WEIGHT		<b>72x65x156</b> DIMENSIONS

MULTIFUEL DUCTING	DUAL POWER	HERMETIC	22° 18° MULTICOMFORT	REMOTE CONTROL LCD
ALKALI FIREBOX CAST-IRON BRACKET	FUEL LEVEL SENSOR	ENERGY SAVING	20 18 20 PROGRAMMING	AUTOMATIC CLEANING
ROLLING FIREBOX	ASH TRAY	PELLET LOADING KIT	VACUUM	OPT. SMS-APP

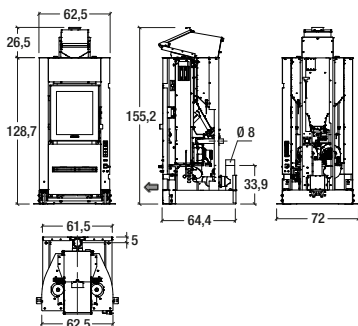

MP980-S WF

Rivestimenti disponibili - Available surrounds P.245



## INSERTI A PELLETT

**Gli inserti a pellet IP permettono di trasformare il caminetto tradizionale aperto in un pratico ed efficiente caminetto garantendo tutto il piacere della fiamma. Alti rendimenti, lunga autonomia, accensione e spegnimento automatici programmabili contraddistinguono gli inserti a pellet Piazzetta: ideali anche per prime installazioni.**

### EN Pellet-burning inserts

The IP pellet-burning inserts allow for transforming a traditional open fireplace into a practical, efficient fireplace guaranteeing all the pleasure of the flame. High performance, extended autonomy, and programmable automatic switching on/off characterise the Piazzetta pellet-burning inserts: ideal also for first-time installation.

### FR Inserts à granulés

Avec les inserts à granulés IP, transformez votre cheminée ouverte en une cheminée pratique et efficace, tout en conservant le plaisir de la flamme. Hauts rendements, longue autonomie, allumage et extinction automatiques programmables sont les atouts des inserts à granulés Piazzetta : parfaits aussi pour une première installation.

### DE Pellet-kamineinsätze

Mit den Pellet-Einsätzen der Baureihe IP verwandelt sich ein herkömmlicher offener Kamin in eine praktische, effiziente Feuerstätte, die dennoch den Genuss des Kaminfeuers bietet. Hohe Wirkungsgrade, lange Autonomie, programmierbares Ein- und Ausschalten zeichnen Piazzetta Pellet-Einsätze aus - auch als Erstinstallationen ideal.

### ES Hogares de pellets

Los hogares de pellets IP transforman la chimenea tradicional abierta en una chimenea práctica y eficiente garantizando todo el placer de la llama. Altos rendimientos, larga autonomía, encendido y apagado automáticos programables son las características de los hogares de pellets Piazzetta: ideales también para primeras instalaciones.

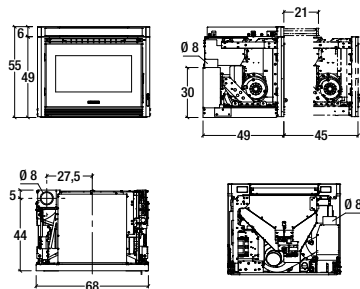

	<b>Type P100</b>		<b>kW Nom. 2,5 - 7,3</b>
	<b>% 84,7 - 85,2</b>		<b>m³ 125 - 210</b>
	<b>kg/h 0,5 - 1,7</b>		<b>kg 8</b>
	<b>4</b>		<b>cm 8</b>
	<b>kg 115</b>		<b>cm (WxDxH) 68x49x49</b>

Model: IP68/49

Rivestimenti disponibili - Available surrounds P.245



# IP 78/58

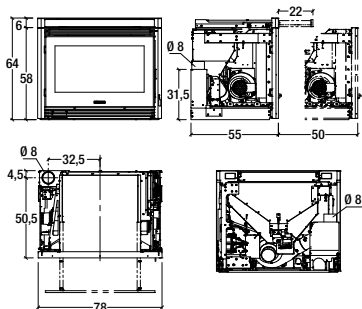

<b>Type P110</b>	<b>kW Nom. 3,1 - 9,0</b>
<b>% 81,5 - 85,1</b>	<b>m<sup>3</sup> 150 - 260</b>
<b>kg/h 0,7 - 2,1</b>	<b>kg 13</b>
<b>5 l</b>	<b>cm 8</b>
<b>kg 120</b>	<b>cm (WxDxH) 78x55x58</b>

Model: IP78/58

Rivestimenti disponibili - Available surrounds P.245

# IP 78/68

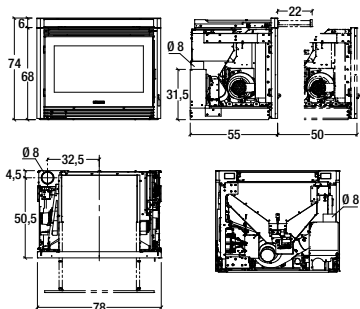

<b>Type P111</b>	<b>kW Nom. 3,4 - 10,8</b>
<b>% 84,1 - 85,3</b>	<b>m<sup>3</sup> 180 - 310</b>
<b>kg/h 0,8 - 2,7</b>	<b>kg 22</b>
<b>5 l</b>	<b>cm 8</b>
<b>kg 150</b>	<b>cm (WxDxH) 78x55x68</b>

Model: IP78/68

Rivestimenti disponibili - Available surrounds P.245

# IP 7

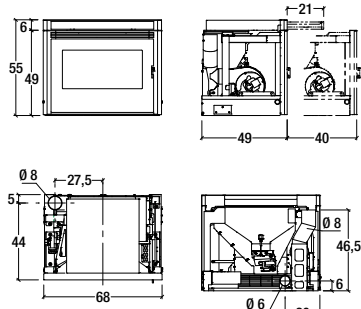

<b>Type YP102-01</b>	<b>kW Nom. 3,5 - 7,0</b>
<b>% 87,3 - 86,1</b>	<b>m<sup>3</sup> 120 - 200</b>
<b>kg/h 0,8 - 1,6</b>	<b>kg 8</b>
<b>4 l</b>	<b>cm 8</b>
<b>kg 100</b>	<b>cm (WxDxH) 68x49x49</b>

Model: IP 7

Rivestimenti disponibili - Available surrounds P.245



# IP 9

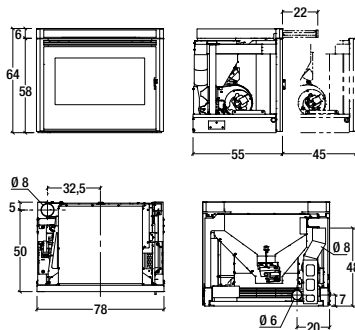

	<b>Type</b> YP113-01		<b>kW Nom.</b> 4,5 - 9,0
	<b>%</b> 88,4 - 87,3		<b>m<sup>3</sup></b> 150 - 260
	<b>kg/h</b> 1,0 - 2,1		<b>kg</b> 13
	<b>5 l</b>		<b>cm</b> 8
	<b>kg</b> 140		<b>cm (WxDxH)</b> 78x55x58

Model: IP 9

Rivestimenti disponibili - Available surrounds P.245

Focolari

# IP 11

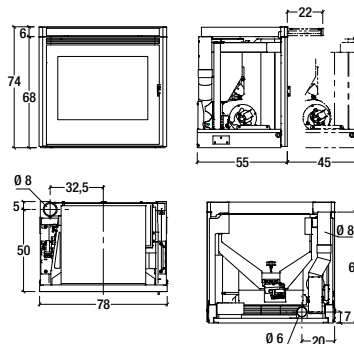

	<b>Type</b> YP115-01		<b>kW Nom.</b> 4,6 - 11,0
	<b>%</b> 87,7 - 87,3		<b>m<sup>3</sup></b> 185 - 315
	<b>kg/h</b> 1,0 - 2,6		<b>kg</b> 22
	<b>5 l</b>		<b>cm</b> 8
	<b>kg</b> 150		<b>cm (WxDxH)</b> 78x55x68

Model: IP 11

Rivestimenti disponibili - Available surrounds P.245

# Thermo SOLUTIONS

I focolari Thermo integrano o sostituiscono la caldaia dell'impianto tradizionale, riqualificandolo e rendendolo più economico, grazie all'utilizzo di un combustibile a biomassa. Possono produrre anche acqua calda ad uso sanitario.

**EN** The Thermo fireboxes integrate or replace the boiler in traditional systems, upgrading the latter and making them more financially convenient thanks to the use of biomass fuel. They can also produce domestic hot water.

**FR** Les foyers Thermo intègrent ou remplacent la chaudière de l'installation traditionnelle qu'ils requalifient et rendent plus économique, grâce à l'utilisation d'un combustible à biomasse. Ils peuvent aussi produire de l'eau chaude sanitaire.

**DE** Die Thermo-Feuerräume ergänzen oder ersetzen den Heizkessel der üblichen Heizungsanlage, die dadurch leistungsfähiger und sparsamer arbeitet, weil ein Biomasse-Brennstoff verwendet wird. Auch eine Brauchwärmwasserebereitung ist möglich.

**ES** Los hogares Thermo integran o sustituyen la caldera de la instalación tradicional, recalificándola y haciéndola más económica, gracias al uso de un combustible de biomasa. Pueden producir también agua caliente para uso sanitario.



**Per riscaldare i radiatori.**

**EN** For heating radiators.  
**FR** Pour chauffer les radiateurs.  
**DE** Zur Beheizung von Heizkörpern.  
**ES** Para calentar los radiadores.



**Per il riscaldamento a pavimento.**

**EN** For underfloor heating.  
**FR** Pour le chauffage au sol.  
**DE** Zur Fussboden-Beheizung.  
**ES** Para la calefacción de suelo.



**Per riscaldare l'acqua ad uso sanitario.**

**EN** For heating domestic water.  
**FR** Pour chauffer l'eau sanitaire.  
**DE** Zur Brauchwasserbereitung.  
**ES** Para calentar agua para uso sanitario.



**Integrabili con il solare termico.**

**EN** Can be integrated with solar heating systems.  
**FR** Intégrables avec le solaire thermique.  
**DE** Zur Kombination mit einer Solaranlage.  
**ES** Integrables con sistema solar térmico.

# Caratteristiche

## HIGH EFFICIENCY



La particolare costruzione dei focolari Thermo, grazie ad innovativi accorgimenti tecnici e all'impiego di materiali altamente performanti, garantisce una elevata efficienza di funzionamento.

### EN High efficiency

Thermo fireboxes are specially built with innovative technical solutions and high-performance materials, which all guarantee high operating efficiency.

### FR Haut rendement

La fabrication particulière des foyers Thermo, grâce à l'utilisation de moyens techniques innovants et de matériaux hautement performants, assure une efficacité de fonctionnement des plus élevées.

### DE Hohe Effizienz

Die besondere Konstruktion der Thermo-Feuerräume gewährleistet dank besonderer technischer Maßnahmen und hochleistungsfähiger Materialien eine hohe Betriebseffizienz.

### ES Alta eficiencia

La particular fabricación de los hogares Thermo, gracias a medidas técnicas innovadoras y al uso de materiales muy eficaces, garantiza una elevada eficiencia de funcionamiento.

## EASY CLEANING



Un semplice gesto periodico consente di garantire sempre un ottimo rendimento, grazie ad un ottimale scambio termico, con un minor consumo di combustibile ed una lunga durata di vita del prodotto.

### EN Easy cleaning

An easy regular gesture allows for having excellent performance at all times, thanks to an optimal heat exchange that ensures lower fuel consumption and long-lasting operation of the product.

### FR Nettoyage simplifié

Un geste périodique simple permet de toujours garantir un excellent rendement, grâce à un échange thermique optimal, avec une consommation de combustible moindre et une durée de vie prolongée du produit.

### DE Einfache Reinigung

Eine einfache, regelmäßig ausgeführte Handlung garantiert fortwährend beste Leistung, denn ein optimaler Wärmeaustausch sorgt für geringeren Brennstoffverbrauch und längere Lebensdauer des Produkts.

### ES Limpieza fácil

Un sencillo gesto periódico permite garantizar siempre un excelente rendimiento, gracias a un eficaz intercambio térmico, con un menor consumo de combustible y una larga vida útil del producto.

## EASY TO INSTALL



Pensati per una facile integrazione con diverse tipologie di impianti idraulici esistenti, sono dotati di elettronica e predisposizioni in grado di far fronte a qualsiasi necessità di gestione.

### EN Straightforward installation

Designed for easily combining with different types of existing plumbing systems, they feature an electronic system and devices for satisfying any control requirements.

### FR Simplicité d'installation

Conçus pour une intégration facile dans plusieurs types d'installations hydrauliques existantes, ils sont dotés d'électronique et sont prévus pour faire face à tout besoin de gestion.

### DE Einfache Installation

Entwickelt für eine einfache Integration in verschiedene bestehende Wasserkreislagen, sind sie mit Elektronik ausgerüstet und so eingerichtet, dass verschiedenste Regelungsbedürfnisse erfüllt werden können.

### ES Instalación sencilla

Pensados para una fácil integración con diferentes tipos de instalaciones hidráulicas existentes, están dotados de electrónica y de características aptas para cualquier necesidad de gestión.



## MAXIMUM IN SAFETY



**I parametri di funzionamento dei focolari Thermo sono costantemente monitorati dall'elettronica che li gestisce. Vengono inoltre verificati anche tutti i valori dell'impianto del circuito idraulico.**

### **EN** Maximum safety

The operating parameters of the Thermo firebox are constantly monitored by the electronic control system. All system and hydraulic circuit parameters are also checked.

### **FR** Sécurité maximale

Les paramètres de fonctionnement des foyers Thermo sont constamment surveillés par l'électronique qui les gère. Toutes les valeurs de l'installation et du circuit hydraulique sont vérifiées elles aussi.

### **DE** Maximale Sicherheit

Die Betriebsparameter der Thermo-Feuerräume werden konstant von der Steuerungselektronik überwacht. Zudem werden auch alle Werte der Anlage und des Wasserkreislaufs geprüft.

### **ES** Máxima seguridad

Los parámetros de funcionamiento de los hogares Thermo son constantemente monitorizados por la electrónica que los gestiona. También se verifican, además, los valores de la instalación y del circuito hidráulico.



### **Pulizia degli scambiatori.**

**EN** Heat exchanger cleaning.  
**FR** Nettoyage des échangeurs.  
**DE** Reinigung des Wärmetauschers.  
**ES** Limpieza de los intercambiadores.

### **Elevata autonomia.**

**EN** Elevated autonomy.  
**FR** Haute autonomie.  
**DE** Hohe Betriebs-Autonomie.  
**ES** Elevada autonomía.

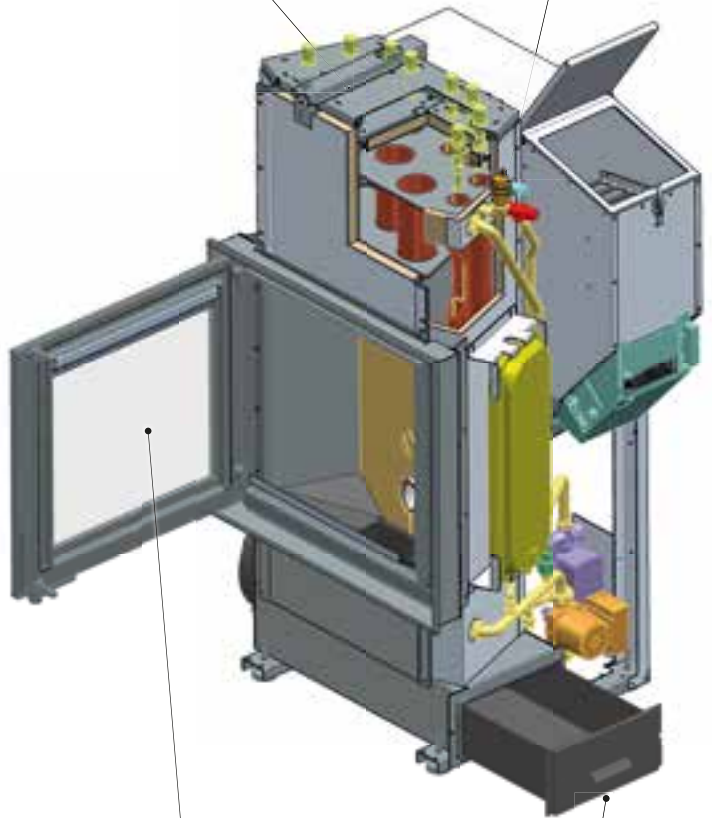

### **Piacevole visione del fuoco.**

**EN** Pleasant view of the fire.  
**FR** Agréable vision du feu.  
**DE** Angenehme Sicht auf das Feuer.  
**ES** Agradable vista del fuego.

### **Cassetto cenere estraibile.**

**EN** Removable ash pan.  
**FR** Tiroir à cendres amovible.  
**DE** Ausziehbarer Aschekasten.  
**ES** Cajón de cenizas extraíble.

# MT



## MT 361



### FOCOLARI THERMO A LEGNA

La gamma dei Focolari Thermo MT a legna è composta da differenti modelli, accomunati da solidità e rendimenti elevati grazie alla nuova caldaia ad alto scambio termico. Installabili con vaso di espansione chiuso o aperto per la massima flessibilità di posa in opera. Kit scambiatore rapido e circolatore per riscaldare anche l'acqua ad uso sanitario.

#### EN Thermo wood-burning fireboxes

The wood-burning MT Thermo Firebox range includes various models, all sturdily built and featuring high performances, thanks to the new boiler with high heat exchange. Installable with closed or open expansion vessel for maximum installation flexibility. Rapid heat exchanger kit and circulator pump to heat water for domestic use.

#### FR Monoblocs thermo à bois

Monoblocs Thermo MT à bois : différents modèles ayant en commun leur solidité et les hauts rendements assurés par la nouvelle chaudière à haut échange thermique. Installation avec vase d'expansion fermé ou ouvert, pour une flexibilité de mise en œuvre maximale. Kit échangeur rapide et circulateur pour la production d'eau chaude sanitaire.

#### DE Thermo holz-heizeinsätze

Die Heizeinsätze der Baureihe Thermo MT für Holzfeuerung umfasst verschiedene Modelle, denen Solidität und hohe Wirkungsgrade dank neuem Kessel mit hohem Wärmeaustausch gemeinsam sind. Mit offenem oder geschlossenem Ausdehnungsgefäß für maximale Installationsflexibilität. Express-Wärmetauscher und Umwälzpumpe zur Brauchwassererwärmung.

#### ES Monobloques termo de leña

Los modelos de la gama de Monobloques Thermo MT de leña se reconocen por la solidez y la alta eficiencia de la nueva caldera de intercambio térmico. Instalables con depósito de expansión cerrado o abierto para la máxima flexibilidad de colocación en obra. Kit intercambiador rápido y bomba de circulación para el agua caliente sanitaria.



<b>ENERGY EFFIC. CLASS</b>	<b>Type MT 361</b>	<b>NOM. kW Nom. 25,5</b>
<b>77,5</b>	<b>% THERMAL EFFICIENCY</b>	<b>TH. kW Th. 14,5</b>
<b>7,2</b>	<b>kg/h CONSUMPTION</b>	<b>AMB. kW Amb. 11,0</b>
<b>95</b>	<b>l BOILER CAPACITY</b>	<b>9,7</b>
<b>1,5</b>	<b>bar MAX. WORKING PRESSURE</b>	<b>25</b>
<b>315</b>	<b>kg WEIGHT</b>	<b>cm (WxDxH) 91x66x171</b>

- STEEL
- ALIKER FIREBOX CAST-IRON BRAZIER
- RISE N'FALL DOOR
- ASH BOX
- MANUAL DAMPER FLUE
- OPT. DOMESTIC HOT WATER
- OPT. DISPLAY WITH SENSOR
- OPT. CIRCULATOR KIT
- OPT. SAFETY VALVE
- OPT. SAFETY KIT OPEN TANK
- OPT. SAFETY KIT CLOSED TANK
- OPT. LOG RETAINER
- OPT. VACUUM

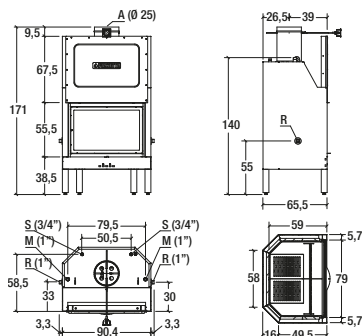

Model: MT 361 15VA

Rivestimenti disponibili - Available surrounds P.245

- STEEL
- ALIKER FIREBOX CAST-IRON BRAZIER
- RISE N'FALL DOOR
- MANUAL DAMPER FLUE
- OPT. SAFETY KIT CLOSED TANK
- OPT. SAFETY KIT OPEN TANK
- OPT. DOMESTIC HOT WATER
- OPT. SAFETY VALVE
- OPT. LOG RETAINER
- OPT. VACUUM

# MT 370



<b>Type MT 361</b>	<b>NOM. kW Nom. 25,5</b> HEAT OUTPUT
<b>% 77,5</b>	<b>TH. kW Th. 14,5</b> HEAT OUTPUT
<b>kg/h 7,2</b>	<b>AMB. kW Amb. 11,0</b> HEAT OUTPUT
<b>l 95</b>	<b>l/min 9,7</b>
<b>bar 1,5</b>	<b>cm 25</b>
<b>kg 305</b>	<b>cm (WxDxH) 91x69x172</b>

Rivestimenti disponibili - Available surrounds P.245

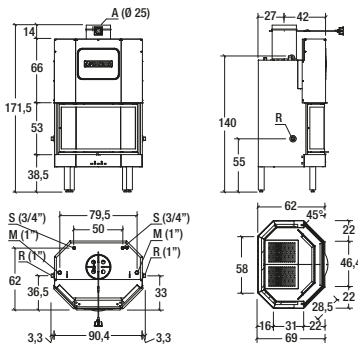
Focolari

# MT 381 D/S



<b>Type MT 381</b>	<b>NOM. kW Nom. 25,5</b> HEAT OUTPUT
<b>% 76,0</b>	<b>TH. kW Th. 15,5</b> HEAT OUTPUT
<b>kg/h 7,8</b>	<b>AMB. kW Amb. 10,0</b> HEAT OUTPUT
<b>l 95</b>	<b>l/min 9,7</b>
<b>bar 1,5</b>	<b>cm 25</b>
<b>kg 315</b>	<b>cm (WxDxH) 91x66x172</b>

Model: MT 381 15 D/S VA

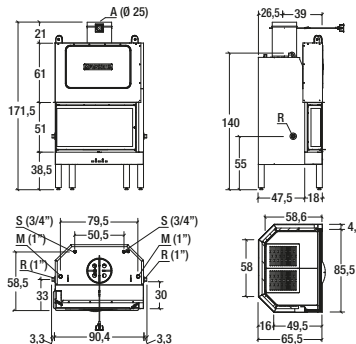
Rivestimenti disponibili - Available surrounds P.245

Focolari

# MT 600



<b>Type THERMO 600</b>	<b>NOM. kW Nom. 19,0</b> HEAT OUTPUT
<b>% 76,0</b>	<b>TH. kW Th. 13,0</b> HEAT OUTPUT
<b>kg/h 5,7</b>	<b>AMB. kW Amb. 6,0</b> HEAT OUTPUT
<b>l 26</b>	<b>l/min 9,7</b>
<b>bar 1,5</b>	<b>cm 20</b>
<b>kg 340</b>	<b>cm (WxDxH) 85x61x169</b>

Model: THERMO 600

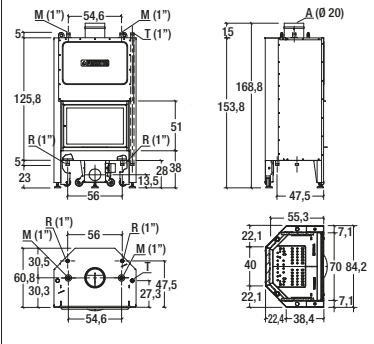
Rivestimenti disponibili - Available surrounds P.245

Focolari

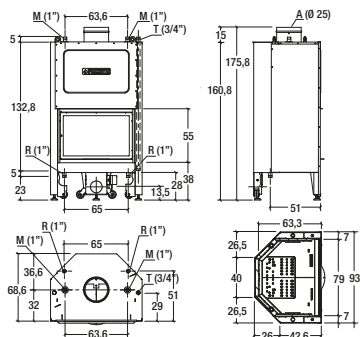

	<b>Type</b> <b>THERMO 610</b>		<b>NOM. kW Nom.</b> <b>26,0</b>
	<b>%</b> <b>76,0</b>		<b>TH. kW Th.</b> <b>18,0</b>
	<b>kg/h</b> <b>8,4</b>		<b>AMB. kW Amb.</b> <b>8,0</b>
	<b>l</b> <b>30</b>		<b>l/min</b> <b>9,7</b>
	<b>bar</b> <b>1,5</b>		<b>cm</b> <b>25</b>
	<b>kg</b> <b>365</b>		<b>cm (WxDxH)</b> <b>93x69x176</b>

## FOCOLARE THERMO A PELLETT

Il Focolare Thermo a pellet MP TH permette di soddisfare ogni esigenza, grazie alla caldaia ad elevato scambio termico che garantisce acqua calda per il circuito idraulico, assicurando condizioni ottimali di benessere nella casa, con tutti i vantaggi di un focolare a pellet. Disponibile anche in versione con produzione istantanea di acqua ad uso sanitario.

### EN Thermo pellet-burning firebox

The pellet-burning MP TH Thermo Firebox fulfils any requirement, thanks to the boiler with high heat exchange guaranteeing hot water in the water supply circuit, for optimal well-being in the home, with all the advantages of a pellet-burning firebox. Also available in the version with instantaneous domestic hot water production.

### DE Thermo pellet-heizeinsätze

Der Pellet-Heizeinsatz Thermo MP TH wird höchsten Ansprüchen gerecht. Der Heizkessel mit hohem Wärmeaustausch stellt Warmwasser für den Wasserkreislauf bereit, sodass optimaler Wohnkomfort gewährleistet ist, mit allen Vorteilen einer Pellet-Feuerstätte. Auch erhältlich als Version mit Durchlauferhitzer zur Brauchwassererzeugung.

### FR Monobloc thermo à granulés

Le Monobloc Thermo à granulés MP TH répond à tous les besoins grâce à sa chaudière à haut échange thermique qui produit l'eau chaude destiné au circuit hydraulique, assurant ainsi un bien-être optimal dans toute la maison, avec tous les avantages d'un foyer à granulés. Disponible avec production instantanée d'eau chaude sanitaire.

### ES Monobloque thermo de pellets

El Monobloque Thermo de pellets MP TH satisface todas las exigencias, gracias a la caldera de alto intercambio térmico que garantiza agua caliente para el circuito hidráulico, asegurando óptimas condiciones de bienestar, con todas las ventajas de un hogar de pellets. Disponible también con posibilidad de producción instantánea de ACS.



STEEL	ALUKER FIREBOX STEEL BRAZIER	AUTOMATIC CLEANING	EXCHANGERS PURGE	AUTO. WATER TEMPERATURE	ELEC. CONTROL PUMP	ANTI-FREEZE FUNCTION	REBURN	SAFETY	REMOTE CONTROL LCD

Rivestimenti disponibili - Available surrounds P.245



# MP 973 TH



# MP 973 TH ACS



<b>Type SP200-01</b>	<b>kW Nom. 9,0 - 30,3</b>
<b>% 92,0 - 91,9</b>	<b>kW Th. 7,5 - 26,4</b>
<b>kg/h 2,0 - 6,8</b>	<b>kW Amb. 1,5 - 3,9</b>
<b>kg 65</b>	<b>l 45</b>
<b>bar 1,5</b>	<b>l/min -</b>
<b>kg 275</b>	<b>cm (WxDxH) 94x61x142</b>

<b>Type SP200-01</b>	<b>kW Nom. 9,0 - 30,3</b>
<b>% 92,0 - 91,9</b>	<b>kW Th. 7,5 - 26,4</b>
<b>kg/h 2,0 - 6,8</b>	<b>kW Amb. 1,5 - 3,9</b>
<b>kg 65</b>	<b>l 45</b>
<b>bar 1,5</b>	<b>l/min 12</b>
<b>kg 279</b>	<b>cm (WxDxH) 94x61x142</b>



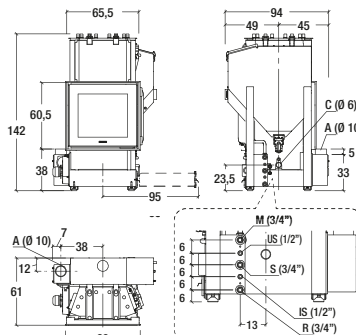
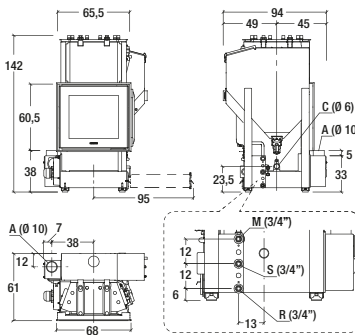

Model: MP973 TH

Model: MP973 TH ACS

Rivestimenti disponibili - Available surrounds P.245

Rivestimenti disponibili - Available surrounds P.245

# Compatibilità



## Tablelle di compatibilità rivestimento-focolare.

**EN Combinations** - Surround-firebox compatibility tables.

**FR Associations** - Tableaux de compatibilité revêtement-monobloc.

**DE Kombinationen** - Kompatibilitätstabellen Verkleidung/Heizeinsatz.

**ES Combinaciones** - Tablas de compatibilidad revestimiento-monobloque.

MODELLO MODEL	PAG PAGE	COMBUSTIBILE FUEL Legna Pellet Wood Pellet	DIMENSIONI (L x H x P) cm DIMENSIONS (W x H x D) cm	FOCOLARI FIREBOXES
ABERDEEN	36	W	80 x 98 x 85,5	MA 274 SL
ACADEMY	100	W	108 x 73 x 8	MA 260 - MA 260 SL - MA 260 B SL - MC 70/51 - MC 70/51 SL - HT 600 - MT 600
ADELAIDE	50	W	123 x 118 x 12	MC 85/55 BL
AMBURGO	70	W	128 x 54 x 10	MA 260 - MA 260 SL - MA 260 B SL - MC 70/51 - MC 70/51 SL - HT 600 - MT 600
		W	148,5 x 47,5 x 10	MA 263 SL - MA 263 B SL - MC 90/44 - MC 90/44 SL - MC 90/44 P
		W	176,5 x 51,5 x 10	MA 264 SL - MC 120/48 - MC 120/48 SL
ARCHEO	166	W	177 x 71 x 4	MA 264 SL - MC 120/48
BARCELONA	150	W	86 x 149 x 7	MA 267 SL - MC 65/60 - MC 65/60 SL - MC 65/60 P
		P	86 x 149 x 7	MP 973
		P	86 x 152 x 7	MP 973 TH - MP 973 TH ACS
BERNA	26	W	75 x 141,6 x 53	MC 65/60
		W	80 x 132,6 x 53	MC 70/51
		W	100 x 125,6 x 53	MC 90/44
		W	128 x 129,6 x 53	MC 120/48
		W	89,6 x 145 x 53	MC 80/64 BL
		W	94,6 x 136 x 53	MC 85/55 BL
		W	114,6 x 129 x 53	MC 105/48 BL
		W	142,6 x 133 x 53	MC 133/52 BL
	P	75 x 142 x 59	MP 973	
BREMA	82	W	106 x 85 x 25	MA 260 - MA 260 SL - MA 260 B SL - MC 70/51 - MC 70/51 SL - HT 600 - MT 600
BRISTOL	42	W	140 x 91 x 75	MA 285 D SL - MA 285 S SL
BRISTOL (panca/bench)	40	W	210 x 91 x 75	MA 285 D SL - MA 285 S SL
CALAIS	96	W	99 x 85 x 4	MA 263 SL - MA 263 B SL - MC 90/44 - MC 90/44 P
CAMBRIDGE	120	W	140 x 80,5 x 28,5	MA 263 SL - MA 263 B SL - MC 90/44 - MC 90/44 SL - MC 90/44 P
CANBERRA	44	W	140 x 124 x 12	MA 263 SL - MA 263 B SL - MC 90/44 - MC 90/44 SL - MC 90/44 P
CAPITAL	114	W	143 x 81 x 10	MA 264 SL - MC 120/48
CARDIFF	38	W	204 x 94,8 x 38	MA 270 SL - MT 370
CHESTER	118	W	171 x 78 x 26	MA 263 SL - MA 263 B SL - MC 90/44 - MC 90/44 SL - MC 90/44 P
CITY	64	W	93 x 72 x 5	MA 260 - MA 260 SL - MA 260 B SL - MC 70/51 - MC 70/51 SL - HT 600 - MT 600
		P	93 x 72 x 5	IP 68/49 - IP 7
CLASS	110	W	100 x 82 x 11	MA 260 - MA 260 SL - MA 260 B SL - MC 70/51 - MC 70/51 SL - HT 600 - MT 600
COLONIA	90	W	73 x 81,5 x 1	MA 260 - MA 260 SL - MA 260 B SL - MC 70/51 - MC 70/51 SL - HT 600 - MT 600
		W	68 x 90,5 x 1	MA 267 SL - MC 65/60 - MC 65/60 SL - MC 65/60 P
		P	68 x 90,5 x 1	MP 973 - MP 973 TH - MP 973 TH ACS
		W	93 x 74,5 x 1	MA 263 SL - MA 263 B SL - MC 90/44 - MC 90/44 SL - MC 90/44 P
		W	121 x 79 x 1	MA 264 SL - MC 120/48 - MC 120/48 SL

MODELLO MODEL	PAG PAGE	COMBUSTIBILE FUEL Legna Pellet Wood Pellet	DIMENSIONI (L x H x P) cm DIMENSIONS (W x H x D) cm	FOCOLARI FIREBOXES
<b>COLORADO</b>	94	W	125 x 70 x 21	MA 263 SL - MA 263 B SL - MC 90/44 - MC 90/44 SL - MC 90/44 P
<b>COLUMBIA</b>	60	W	115 x 69 x 3,5	MA 263 SL - MA 263 B SL - MC 90/44 - MC 90/44 SL - MC 90/44 P
<b>CRUISE</b>	130	W	151,5 x 199 x 22,5	MA 262 SL
<b>DARWIN</b>	46	W	110 x 89 x 6	MA 260 - MA 260 SL - MA 260 B SL - MC 70/51 - MC 70/51 SL - HT 600 - MT 600
		P	110 x 89 x 6	IP 68/49 - IP 7
		W	106 x 98 x 6	MA 267 SL - MC 65/60 - MC 65/60 SL - MC 65/60 P
		P	106 x 98 x 6	MP 973 - MP 973 TH - MP 973 TH ACS
<b>DAVOS</b>	28	W	75 x 185,5 x 53	MC 65/60
		W	80 x 176,5 x 53	MC 70/51
		W	100 x 169,5 x 53	MC 90/44
		W	128 x 173,5 x 53	MC 120/48
		W	89,6 x 189 x 53	MC 80/64 BL
		W	94,6 x 180 x 53	MC 85/55 BL
		W	114,6 x 173 x 53	MC 105/48 BL
		W	142,6 x 177 x 53	MC 133/52 BL
<b>DERBY</b>	160	W	80 x 220 x 22	MA 266 SL
<b>DOGE</b>	148	W	180 x 215 x 55	HT 760T
<b>DRESDA</b>	86	W	111 x 94 x 6	MA 260 - MA 260 SL - MA 260 B SL - MC 70/51 - MC 70/51 SL - HT 600 - MT 600
		W	121 x 94 x 6	MA 261 - MA 261 SL - HT 610 - HT 2010B - MT 610 - MT 361
		P	121 x 94 x 6	IP 68/49 - IP 7
<b>EASY</b>	66	W	95 x 76 x 3,5	MA 260 - MA 260 SL - MA 260 B SL - MC 70/51 - MC 70/51 SL - HT 600 - MT 600
		W	90 x 85 x 3,5	MA 267 SL - MC 65/60 - MC 65/60 SL - MC 65/60 P
		P	90 x 85 x 3,5	MP 973 - MP 973 TH
		W	115 x 69 x 3,5	MA 263 SL - MA 263 B SL - MC 90/44 - MC 90/44 SL - MC 90/44 P
		W	115 x 95 x 3,5	MA 262 SL
		W	104,5 x 80 x 3,5	MA 261 - MA 261 SL - HT 610 - HT 2010B - MT 361 - MT 610
		W	80 x 100 x 3,5	HT 650
		W	143 x 73 x 3,5	MA 264 SL - MC 120/48 - MC 120/48 SL
		W	80,5 x 85 x 3,5	IL 52/57 M
		W	107 x 91 x 3,5	MC 80/64 BL
		W	112 x 82 x 3,5	MC 85/55 BL
		W	132 x 75 x 3,5	MC 105/48 BL
		W	160 x 79 x 3,5	MC 133/52 BL
		P	95 x 76/82 x 3,5	IP 68/49 - IP 7
P	104,5 x 85/90,5 x 3,5	IP 78/58 - IP 9		
P	104,5 x 95/100 x 3,5	IP 78/68 - IP 11		
<b>EDINBURGH</b>	32	W	140 x 91 x 147	MA 272 SL
<b>EOS</b>	168	W	177 x 71 x 4	MA 264 SL - MC 120/48
<b>ESSEN</b>	88	W	97,5 x 78,5 x 6	MA 260 - MA 260 SL - MA 260 B SL - MC 70/51 - MC 70/51 SL - HT 600 - MT 600
		W	93 x 88 x 6	MA 267 SL - MC 65/60 - MC 65/60 SL - MC 65/60 P
		W	118 x 72 x 6	MA 263 SL - MA 263 B SL - MC 90/44 - MC 90/44 SL - MC 90/44 P
		W	146 x 76 x 6	MA 264 SL - MC 120/48 - MC 120/48 SL
		P	97,5 x 78,5 x 6	IP 68/49 - IP 7
		P	93 x 88 x 6	MP 973 - MP 973 TH - MP 973 TH ACS
<b>FENICE</b>	146	W	152 x 205 x 37	HT 760T
<b>FORUM</b>	102	W	108 x 73 x 8	MA 260 - MA 260 SL - MA 260 B SL - MC 70/51 - MC 70/51 SL - 600 HT - MT 600
<b>FOX</b>	126	W	151,5 x 191 x 22	MA 263 SL - MA 263 B SL - MC 90/44 - MC 90/44 SL - MC 90/44 P
<b>FOX 1</b>	132	W	123 x 118 x 12	MA 263 SL - MA 263 B SL - MC 90/44 - MC 90/44 SL - MC 90/44 P
<b>FREE</b>	142	W	141 x 210 x 23	MA 263 SL - MA 263 B SL - MC 90/44 - MC 90/44 P

MODELLO MODEL	PAG PAGE	COMBUSTIBILE FUJEL		DIMENSIONI (L x H x P) cm DIMENSIONS (W x H x D) cm	FOCOLARI FIREBOXES
		Legna Wood	Pellet Pellet		
FRIBURGO	72	W		93,5 x 54 x 5	MA 260 - MA 260 SL - MA 260 B SL - MC 70/51 - MC 70/51 SL - HT 600 - MT 600
		W		114 x 47,5 x 5	MA 263 SL - MA 263 B SL - MC 90/44 - MC 90/44 SL - MC 90/44 P
		W		142 x 51,5 x 5	MA 264 SL - MC 120/48 - MC 120/48 SL
GALLERY	104	W		125 x 72 x 5	MA 260 - MA 260 SL - MA 260 B SL - MC 70/51 - MC 70/51 SL - 600 HT - MT 600
			P	125 x 72 x 5	IP 68/49 - IP 7
GRAZ	56	W		195,5 x 72 x 15,2	MA 263 SL - MA 263 B SL - MC 90/44 - MC 90/44 SL - MC 90/44 P
		W		223,5 x 72 x 15,2	MA 264 SL - MC 120/48 - MC 120/48 SL
HOBART	22	W		47 x 220 x 50	E928 WF - E928 WF Hermetic.BCS
		W		47 x 250 x 50	E928 WF - E928 WF Hermetic.BCS
		W		91 x 219 x 53	MC 90/44 - MC 90/44 P
		W		91 x 261 x 53	MC 90/44 - MC 90/44 P
			P	66 x 210 x 78	MP 980 - MP 980 Hermetic
			P	66 x 261 x 78	MP 980 - MP 980 Hermetic
KENSINGTON	34	W		140 x 91 x 86	MA 271 SL
KOSMOS	164	W		177 x 71 x 4	MA 263 SL - MA 263 B SL - MC 90/44 - MC 90/44 P
LANCASTER	154	W		140 x 207 x 75	MA 266 SL
LEEDS	144	W		83 x 185,5 x 15	HT 555T SL
LIFE	138	W		110 x 183 x 20	MA 260 - MA 260 SL - MA 260 B SL - MC 70/51 - MC 70/51 SL - 600 HT - MT 600
			P	110 x 183 x 20	IP 68/49 - IP 7
LINZ	54	W		191 x 66,6 x 26	MA 263 SL - MA 263 B SL - MC 90/44 - MC 90/44 SL - MC 90/44 P
		W		219 x 66,6 x 26	MA 264 SL - MC 120/48 - MC 120/48 SL
LIPSIA	68	W		165,5 x 60 x 2	MA 260 - MA 260 SL - MA 260 B SL - MC 70/51 - MC 70/51 SL - HT 600 - MT 600
			P	165,5 x 60 x 2	IP 68/49 - IP 7
		W		185,8 x 53 x 2	MA 263 SL - MA 263 B SL - MC 90/44 - MC 90/44 SL - MC 90/44 P
		W		213,5 x 57 x 2	MA 264 SL - MC 120/48 - MC 120/48 SL
LITHOS	174	W		113 x 74 x 4	MA 260 - MA 260 SL - MA 260 B SL - MC 70/51 - MC 70/51 SL - 600 HT - MT 600
			P	113 x 74 x 4	IP 68/49 - IP 7
LUBECCA	84	W		105,5 x 78,5 x 5,3	MA 260 - MA 260 SL - MA 260 B SL - MC 70/51 - MC 70/51 SL - HT 600 - MT 600
LUGANO	24	W		75 x 141 x 53	MC 65/60
		W		80 x 132 x 53	MC 70/51
		W		100 x 125 x 53	MC 90/44
		W		128 x 129 x 53	MC 120/48
		W		89,6 x 144 x 53	MC 80/64 BL
		W		94,6 x 135 x 53	MC 85/55 BL
		W		114,6 x 128 x 53	MC 105/48 BL
		W		142,6 x 132 x 53	MC 133/52 BL
MELBOURNE	48	W		90 x 145 x 12	MA 267 SL - MC 65/60 - MC 65/60 SL - MC 65/60 P
			P	90 x 145 x 12	MP 973 - MP 973 TH - MP 973 TH ACS
MOOD	128	W		123 x 121,5 x 0,5	MA 262 SL
NEW ORLEANS	92	W		114 x 73 x 8	MA 263 SL - MA 263 B SL - MC 90/44 - MC 90/44 SL - MC 90/44 P
NEWPORT	30	W		140 x 140 x 58	MC 85/55 BL
PALEO	172	W		93 x 74 x 4	MA 260 - MA 260 SL - MA 260 B SL - MC 70/51 - MC 70/51 SL - 600 HT - MT 600
			P	93 x 74 x 4	IP 68/49 - IP 7
PERTH	152		P	55 x 102 x 9	MP 938
PHILADELPHIA	58	W		143 x 73 x 4,5	MA 264 SL - MC 120/48
PHOENIX	76	W		185,5 x 73 x 4	MA 264 SL - MC 120/48 - MC 120/48 SL
PORTALE	162	W		103 x 142 x 26	HT 650
PRESTON	52	W		74,5 x 191 x 0,5	MC 70/51

MODELLO MODEL	PAG PAGE	COMBUSTIBILE FUEL Legna Pellet Wood Pellet	DIMENSIONI (L x H x P) cm DIMENSIONS (W x H x D) cm	FOCOLARI FIREBOXES
<b>SALISBURGO</b>	78	W	135 x 79 x 3,5	MA 263 SL - MA 263 B SL - MC 90/44 - MC 90/44 SL - MC 90/44 P
		W	163 x 83 x 3,5	MA 264 SL - MC 120/48 - MC 120/48 SL
<b>SAN DIEGO</b>	116	W	135 x 134 x 12	MA 263 SL - MA 263 B SL - MC 90/44 - MC 90/44 SL - MC 90/44 P
<b>SHEFFIELD</b>	122	W	149,5 x 64,5 x 22	MA 265 SL
<b>SHUTTLE</b>	140	W	110 x 97 x 20	MC 70/51
		P	110 x 97 x 20	IP 68/49 - IP 7
<b>SHUTTLE 1</b>	136	W	141 x 141 x 56	MC 70/51
		P	141 x 141 x 56	IP 68/49 - IP 7
<b>SIGNS</b>	74	W	170 x 69 x 4	MA 263 SL - MA 263 B SL - MC 90/44 - MC 90/44 P
<b>SUN</b>	98	W	153 x 73 x 10	MA 264 SL - MC 120/48
<b>SURFACE</b>	124	W	136 x 176 x 4,7	MA 264 SL - MC 120/48
<b>VIENNA</b>	80	W	120 x 87,5 x 3,5	MA 260 - MA 260 SL - MA 260 B SL - MC 70/51 - MC 70/51 SL - HT 600 - MT 600
		P	120 x 87,5 x 3,5	IP 68/49 - IP 7
		W	115,5 x 96 x 3,5	MA 267 SL - MC 65/60 - MC 65/60 SL - MC 65/60 P
		P	115,5 x 96 x 3,5	MP 973 - MP 973 TH - MP 973 TH ACS
<b>VILLAGE</b>	62	W	143 x 73 x 4,5	MA 264 SL - MC 120/48 - MC 120/48 SL
<b>VISION</b>	106	W	126 x 92 x 4,5	MA 260 - MA 260 SL - MA 260 B SL - MC 70/51 - MC 70/51 SL - HT 600 - MT 600
		P	126 x 92 x 4,5	IP 68/49 - IP 7
<b>VOYAGER</b>	108	W	126 x 92 x 4,5	MA 260 - MA 260 SL - MA 260 B SL - MC 70/51 - MC 70/51 SL - 600 HT - MT 600
		P	126 x 92 x 4,5	IP 68/49 - IP 7
<b>WAYS</b>	170	W	185 x 60 x 15	MA 260 - MA 260 SL - MA 260 B SL - MC 70/51 - MC 70/51 SL - 600 HT - MT 600
		P	185 x 60 x 15	IP 68/49 - IP 7
<b>WITH YOU</b>	134	W	115 x 115 x 16,5	MA 260 - MA 260 SL - MA 260 B SL - MC 70/51 - MC 70/51 SL - 600 HT - MT 600
		P	115 x 115 x 16,5	IP 68/49 - IP 7
<b>YORK</b>	158	W	94 x 138 x 12	MA 266 SL
<b>YORK</b> (mensola/shelf)	156	W	160 x 138 x 12	MA 266 SL
<b>ZEUS</b>	112	W	100 x 82 x 11	MA 260 - MA 260 SL - MA 260 B SL - MC 70/51 - MC 70/51 SL - 600 HT - MT 600

# Focolari



## Tabelle di compatibilità focolare-rivestimento.











































**EN Fireboxes** - Firebox-surround compatibility tables.

**FR Monoblocs** - Tableaux de compatibilité monobloc-revêtement.

**DE Heizeinsätze** - Kompatibilitätstabellen Heizeinsatz/Verkleidung.

**ES Monobloques** - Tablas de compatibilidad monobloque-revestimiento.

FOCOLARI FIREBOXES	PAG PAGE	VERS.	MODELLI MODELS
<b>LEGNA - WOOD</b>			
<b>MC 80/64 BL</b>	196		BERNA, DAVOS, EASY, LUGANO
<b>MC 85/55 BL</b>	197		ADELAIDE, BERNA, DAVOS, EASY, LUGANO, NEWPORT
<b>MC 105/48 BL</b>	197		BERNA, DAVOS, EASY, LUGANO
<b>MC 133/52 BL</b>	197		BERNA, DAVOS, EASY, LUGANO
<b>MC 65/60 SL</b>	198		BARCELONA, COLONIA, DARWIN, EASY, ESSEN, MELBOURNE, VIENNA
<b>MC 70/51 SL</b>	199		ACADEMY, AMBURGO, BREMA, CITY, CLASS, COLONIA, DARWIN, DRESDA, EASY, ESSEN, FORUM, FRIBURGO, GALLERY, LIFE, LIPSIA, LITHOS, LUBECCA, PALEO, VIENNA, VISION, VOYAGER, WAYS, WITH YOU, ZEUS
<b>MC 90/44 SL</b>	199		AMBURGO, FOX, EASY, CANBERRA, FRIBURGO, FOX 1, COLORADO, LINZ, GRAZ, ESSEN, SALISBURGO, LIPSIA, CHESTER, CAMBRIDGE, SAN DIEGO, COLUMBIA, COLONIA
<b>MC 120/48 SL</b>	199		AMBURGO, COLONIA, EASY, ESSEN, FRIBURGO, GRAZ, LINZ, LIPSIA, PHILADELPHIA, PHOENIX, SALISBURGO, VILLAGE
<b>MC 65/60 PLUS</b>	200		BARCELONA, COLONIA, DARWIN, EASY, ESSEN, MELBOURNE, VIENNA
<b>MC 65/60</b>	201		BARCELONA, COLONIA, DARWIN, EASY, ESSEN, MELBOURNE, VIENNA, LUGANO, DAVOS, BERNA
<b>MC 70/51</b>	201		ACADEMY, AMBURGO, BREMA, CITY, CLASS, COLONIA, DARWIN, DRESDA, EASY, ESSEN, FORUM, FRIBURGO, GALLERY, LIFE, LIPSIA, LITHOS, LUBECCA, PALEO, PRESTON, SHUTTLE, SHUTTLE 1, VIENNA, VISION, VOYAGER, WAYS, WITH YOU, WITH YOU, ZEUS, LUGANO, DAVOS, BERNA
<b>MC 90/44 PLUS</b>	201		AMBURGO, CALAIS, CAMBRIDGE, CANBERRA, CHESTER, COLONIA, COLORADO, COLUMBIA, EASY, ESSEN, FOX, FOX 1, FREE, FRIBURGO, GRAZ, HOBART, KOSMOS, LINZ, LIPSIA, NEW ORLEANS, SALISBURGO, SAN DIEGO, SIGNS
<b>MC 90/44</b>	202		AMBURGO, BERNA, CALAIS, CAMBRIDGE, CANBERRA, CHESTER, COLONIA, COLORADO, COLUMBIA, DAVOS, EASY, ESSEN, FOX, FOX 1, FREE, FRIBURGO, GRAZ, HOBART, KOSMOS, LINZ, LIPSIA, LUGANO, NEW ORLEANS, SALISBURGO, SAN DIEGO, SIGNS
<b>MC 120/48</b>	202		AMBURGO, ARCHEO, BERNA, CAPITAL, COLONIA, DAVOS, EASY, EOS, ESSEN, FRIBURGO, GRAZ, LINZ, LIPSIA, LUGANO, PHILADELPHIA, PHOENIX, SALISBURGO, SUN, SURFACE, VILLAGE
<b>MA 260 SL</b>	203		ACADEMY, AMBURGO, BREMA, CITY, CLASS, COLONIA, DARWIN, DRESDA, EASY, ESSEN, FORUM, FRIBURGO, GALLERY, LIFE, LIPSIA, LITHOS, LUBECCA, PALEO, VIENNA, VISION, VOYAGER, WAYS, WITH YOU, ZEUS
<b>MA 260 B SL</b>	204		ACADEMY, AMBURGO, BREMA, CITY, CLASS, COLONIA, DARWIN, DRESDA, EASY, ESSEN, FORUM, FRIBURGO, GALLERY, LIFE, LIPSIA, LITHOS, LUBECCA, PALEO, VIENNA, VISION, VOYAGER, WAYS, WITH YOU, ZEUS
<b>MA 261 SL</b>	204		DRESDA, EASY
<b>MA 262 SL</b>	204		CRUISE, EASY, MOOD
<b>MA 263 SL</b>	205		AMBURGO, CALAIS, CAMBRIDGE, CANBERRA, CHESTER, COLONIA, COLORADO, COLUMBIA, EASY, ESSEN, FOX, FOX 1, FREE, FRIBURGO, GRAZ, KOSMOS, LINZ, LIPSIA, NEW ORLEANS, SALISBURGO, SAN DIEGO, SIGNS
<b>MA 263 B SL</b>	205		AMBURGO, CALAIS, CAMBRIDGE, CANBERRA, CHESTER, COLONIA, COLORADO, COLUMBIA, EASY, ESSEN, FOX, FOX 1, FREE, FRIBURGO, GRAZ, KOSMOS, LINZ, LIPSIA, NEW ORLEANS, SALISBURGO, SAN DIEGO, SIGNS
<b>MA 264 SL</b>	205		AMBURGO, ARCHEO, CAPITAL, COLONIA, EASY, EOS, ESSEN, FRIBURGO, GRAZ, LINZ, LIPSIA, PHILADELPHIA, PHOENIX, SALISBURGO, SUN, SURFACE, VILLAGE
<b>MA 265 SL</b>	206		SHEFFIELD
<b>MA 266 SL</b>	206		DERBY, LANCASTER, YORK SENZA PANCA, YORK CON PANCA
<b>MA 267 SL</b>	206		BARCELONA, COLONIA, DARWIN, EASY, ESSEN, MELBOURNE, VIENNA
<b>MA 270 SL</b>	207		CARDIFF

FOCOLARI FIREBOXES	PAG PAGE	VERS.	MODELLI MODELS
MA 271 SL	207		KENSINGTON
MA 272 SL	207		EDINBURGH
MA 274 SL	208		ABERDEEN
MA 285 D SL	209		BRISTOL CON PANCA, BRISTOL SENZA PANCA
MA 285 S SL	209		BRISTOL CON PANCA, BRISTOL SENZA PANCA
MA 260	210, 211		ACADEMY, AMBURGO, BREMA, CITY, CLASS, COLONIA, DARWIN, DRESDA, EASY, ESSEN, FORUM, FRIBURGO, GALLERY, LIFE, LIPSIA, LITHOS, LUBECCA, PALEO, VIENNA, VISION, VOYAGER, WAYS, WITH YOU, ZEUS
MA 261	211		DRESDA, EASY
HT 600	214		ACADEMY, AMBURGO, BREMA, CITY, CLASS, COLONIA, DARWIN, DRESDA, EASY, ESSEN, FORUM, FRIBURGO, GALLERY, LIFE, LIPSIA, LITHOS, LUBECCA, PALEO, VIENNA, VISION, VOYAGER, WAYS, WITH YOU, ZEUS
HT 610	215		DRESDA, EASY
HT 650	215		EASY, PORTALE
HT 760T	216		DOGE, FENICE
HT 2010B	217		DRESDA, EASY
HT 555T SL	218		LEEDS
IL 52/57 M	222		EASY
E928 WF	225		HOBART
E928 WF HERMETIC BCS	225		HOBART
MT 361	236		DRESDA, EASY
MT 370	237		CARDIFF
MT 600	237		ACADEMY, AMBURGO, BREMA, CITY, CLASS, COLONIA, DARWIN, DRESDA, EASY, ESSEN, FORUM, FRIBURGO, GALLERY, LIFE, LIPSIA, LITHOS, LUBECCA, PALEO, VIENNA, VISION, WAYS, WITH YOU, ZEUS
MT 610	238		EASY, DRESDA
<b>PELLET</b>			
MP 938	226		PERTH
MP 973	227		BARCELONA, BERNA, COLONIA, DARWIN, ESSEN, EASY, MELBOURNE, VIENNA
MP 980	227		HOBART
MP 980 HERMETIC	228		HOBART
IP 68/49	229		CITY, DARWIN, DRESDA, EASY, ESSEN, FORUM, GALLERY, LIFE, LIPSIA, LITHOS, PALEO, SHUTTLE, SHUTTLE 1, VIENNA, VISION, VOYAGER, WAYS, WITH YOU
IP 78/58	230		EASY
IP 78/68	230		EASY
IP 7	230		CITY, DARWIN, DRESDA, EASY, ESSEN, FORUM, GALLERY, LIFE, LIPSIA, LITHOS, PALEO, SHUTTLE, SHUTTLE 1, VIENNA, VISION, VOYAGER, WAYS, WITH YOU
IP 9	231		EASY
IP 11	231		EASY
MP 973 TH	239		BARCELONA, COLONIA, DARWIN, EASY, ESSEN, VIENNA, MELBOURNE
MP 973 TH ACS	239		BARCELONA, COLONIA, DARWIN, EASY, ESSEN, VIENNA, MELBOURNE
<b>LEGENDA VERSIONI - VERSIONS KEY - LÉGENDE DES VERSIONS - LEGENDE DER VERSIONEN - LEYENDA VERSIONES</b>			
	<b>Chiuso</b> - Closed - Fermé - Geschlossen - Cerrado		
	<b>Aperto</b> - Open - Ouvert - Geöffneten - Abierto		
	<b>Bifacciale</b> - Double-face - Double face - Beidseitig - Doble cara		
	<b>Tre vetri</b> - Three glass panels - Trois vitres - Drei Scheiben - Tres vidrios		
	<b>Destro</b> - Right-hand - Droite - Rechts - Derecho		
	<b>Sinistro</b> - Left-hand - Gauche - Links - Izquierdo		
	<b>Esagonale</b> - Hexagonal - Hexagonal - Sechseckig - Hexagonal		
	<b>Quadrato</b> - Square - Carré - Quadratisch - Cuadrado		
	<b>Tondo</b> - Round - Rond - Rund - Redondo		
	<b>Semitondo</b> - Semi-round - Demi-cercle - Halbrund - Semirredondo		

# Legenda

Le caratteristiche tecniche e funzionali dei focolari Piazzetta, i loro plus di serie e gli accessori disponibili, sono indicati con delle icone di seguito descritte. Scegli il prodotto ideale per il tuo ambiente e le caratteristiche che soddisfano le tue necessità.

## EN Key

The technical and functional characteristics of Piazzetta fireboxes, their standard features and available accessories, are indicated by the icons described below. Choose the ideal product for your environment and the characteristics that satisfy your needs.

## FR Légende

Les caractéristiques techniques et fonctionnelles des foyers Piazzetta, leurs « plus » de série et les accessoires disponibles, sont indiqués par les icônes décrites ci-après. Choisissez le produit idéal pour votre intérieur et les caractéristiques aptes à satisfaire vos besoins.

## DE Legende

Die technischen und funktionellen Eigenschaften der Piazzetta Feuerräume, ihre serienmäßige Ausstattung und das verfügbare Zubehör sind durch die folgenden Symbole angegeben. Wählen Sie das zu Ihrem Ambiente passende Produkt und die Merkmale, die Ihre Anforderungen erfüllen.

## ES Leyenda

Las características técnicas y funcionales de los hogares Piazzetta, su dotación de serie y los accesorios disponibles se indican con los siguientes iconos. Elige el producto ideal para tu ambiente y las características que respondan a tus necesidades.

	Classe energetica	Energy class	Classe énergétique	Energieeffizienzklasse	Clase de eficiencia energética
	Potenza termica nominale	Rated heat output	Puissance thermique nominale	Nennwärmeleistung	Potencia térmica nominal
	Rendimento termico	Thermal efficiency	Rendement thermique	Wirkungsgrad	Rendimiento térmico
	Volume riscaldabile	Heatable volume	Volume chauffable	Raumheizvermögen	Volumen calefaccionado
	Potenza termica all'acqua	Heat output to the water	Puissance thermique à l'eau	Wasser-Wärmeleistung	Potencia térmica al agua
	Potenza termica all'ambiente	Heat output to the room	Puissance thermque à l'air	Umweltwärmeleistung	Energía térmica para el ambiente
	Portata acqua sanitaria	Water flow rate	Débit d'eau domestique	Wärmeleistung ans Wasser	Potencia térmica al agua
	Capienza boiler	Boiler capacity	Capacité boiler	Kessellkapazität	Capacidad boiler
	Capienza serbatoio	Hopper capacity	Contenance du réservoir	Behälter-Fassungsvermögen	Capacidad del depósito
	Pressione massimo esercizio	Maximum working pressure	Pression d'exercice maximale	Maximaler Betriebsdruck	Presión máxima de servicio





















 CONSUMPTION	Consumo nominale legna	Rated consumption wood	Consommation nominale bois	Nominaler Holzverbrauch	Consumo nominal leña
 CONSUMPTION	Consumo nominale pellet	Rated consumption pellet	Consommation nominale pellet	Nominaler Pelletverbrauch	Consumo nominal pellet
 LEVEL POWER	Livelli di potenza	Power levels	Niveaux de puissance	Leistungsstufen	Niveles de potencia
 WEIGHT	Peso	Weight	Poids	Ofengewicht	Peso
 FLUE DIAM.	Diámetro scarico fumi	Flue outlet diameter	Diamètre de la sortie des fumées	Durchmesser Rauchabzug	Diámetro de la salida de humos
 DIMENSIONS	Dimensioni della stufa	Stove dimensions	Dimensions du poêle	Abmessungen des Ofens	Medidas de la estufa

**Caratteristiche / Features**



 PARALLEL LIFT-UP DOOR	Apertura anta basculante	Parallel lift-up door	Porte basculante	Hochschwenkbare Türöffnung	Apertura basculante
 RISE N'FALL DOOR	Apertura anta saliscendi	Rise n'fall door	Porte escamotable	Hochschiebbare Türöffnung	Puerta con mecanismo "Sube y Baja"
 HINGED DOOR	Porta reversibile	Reversible door	Porte réversible	Umkehrbare Türe	Puerta reversible
 TERTIARY AIR	Sistema con aria terziaria	Tertiary air system	Système avec air tertiaire	Tertiärluftsystem	Sistema con aire terciario
 ALUKER BRAZIER-FIREBOX	Focolare e Braciere in Aluker®	Firebox and Brazier in Aluker®	Foyer et Brasero en Aluker®	Heizeinsatz und Brenntopf aus Aluker®	Hogar y Brasero de Aluker®
 ALUKER FIREBOX CAST-IRON BRAZIER	Focolare in Aluker® Braciere in ghisa	Firebox in Aluker® Brazier in cast iron	Foyer en Aluker® Brasero en fonte	Heizeinsatz aus Aluker®, Brenntopf aus Gusseisen	Hogar de Aluker®, Brasero de hierro fundido
 CAST-IRON FIREBOX	Focolare in ghisa	Firebox in cast-iron	Foyer en fonte	Brennkammer aus Gusseisen	Hogar en fundición
 ALUKER FIREBOX STEEL BRAZIER	Focolare in Aluker® Braciere in acciaio	Firebox in Aluker® Brazier in steel	Foyer en Aluker® Brasero en acier	Brennkammer aus Aluker® mit Feuerrost aus Stahl	Hogar en fundición Aluker® Brazero en acero
 ALUKER	Focolare in Aluker®	Firebox in Aluker®	Foyer en Aluker®	Brennkammer aus Aluker®	Hogar en fundición Aluker®
 COOKING PLATE CAST-IRON	Piano cottura in ghisa	Cooking plate in cast iron	Plaque de cuisson en fonte	Gusseisen Herd	Cocina de hierro fundido

## Characteristics

	Struttura in Acciaio	Steel structure	Structure en acier	Stahlstruktur	Estructura en acero
	Cassetto cenere estraibile	Removable ash pan	Tiroir à cendres amovible	Ausziehbarer Aschekasten	Cajón de cenizas extraíble
	Easy Cleaning	Easy Cleaning	Easy Cleaning	Easy Cleaning	Easy Cleaning
	Registro fumi manuale	Manual damper flue	Clapet des fumées manuel	Manuelle Drosselklappe	Registro humos regulable manualmente
	Registro fumi automatico	Automatic damper flue	Clapet des fumées automatique	Automatische Drosselklappe	Registro humos automatico
	Cappa orientabile	Adjustable flue connector	Raccordement des fumées réglable	Schwenkbare Haube	Campana orientable
	Semplicità di installazione	Easy to install	Installation aisée	Einfache Installation	Simplicidad de instalación
	Funzione attivabile per ottimizzare i consumi, per il massimo risparmio	Function that can be activated to optimise consumption, for maximum saving	Fonction activable pour optimiser la consommation, pour un maximum d'économie	Zur Optimierung des Verbrauchs aktivierbare Funktion, für sparsamen Betrieb	Función activable para optimizar los consumos, para el máximo ahorro
	Funzione eco	Eco function	Fonction éco	Eco function	Eco function
	Multicomfort	Multicomfort	Multicomfort	Multicomfort	Multicomfort
	Kit per la ventilazione forzata non canalizzabile	Kit for non-ductable forced ventilation	Kit de ventilation forcée non canalisable	Kit ohne kanalisierte Gebläselüftung	Kit para la ventilación forzada no canalizable
	Multifuoco® System	Multifuoco® System	Multifuoco® System	Multifuoco® System	Multifuoco® System
	Multifuoco® System Plus	Multifuoco® System Plus	Multifuoco® System Plus	Multifuoco® System Plus	Multifuoco® System Plus
	Dual power	Dual power	Dual power	Dual power	Dual power
	Elevata autonomia	Extended burn time	Grande autonomie	Große Autonomie	Alta autonomía
	Sensore livello serbatoio pellet, avviso per ricarica	Pellet hopper level sensor, warning for reloading	Capteur de niveau du réservoir à pellet, avis de chargement	Pelletbehälter-Füllstandsensor mit Nachlademeldung	Sensor de nivel del depósito de pellets, aviso para recarga
	Kit caricamento pellet optional	Optional pellet loading kit	Kit de chargement en optionnel	Pelletladeset optional	Kit carga pellet opcional

	Braciere in acciaio	Steel brazier	Brasero en acier	Brenntopf aus Stahl	Brasero de acero
	Kit serbatoio supplementare optional	Optional extra hopper kit	Kit réservoir supplémentaire en option	Optionales zusätzliches Tank-Kit	Kit deposito adicional opcional
	Display a comandi digitali	Digital display	Écran permettant de gérer son fonctionnement	Display zum Steuern des Betriebs	Display para gestionar el funcionamiento
	Temperatura acqua automatizzata	Water temperature management	Gestion électronique temperature de l'eau	Automatisierte Wassertemperatur	Temperatura agua automatizada
	Sistema di pulizia ciclica del braciere	Cyclical brazier cleaning system	Système de nettoyage périodique du brasero	System zur zyklischen Reinigung des Brenntopfs	Sistema de limpieza ciclica del brasero
	Sistema di pulizia degli scambiatori ad elementi rotanti	Heat exchanger cleaning system with rotating elements	Système de nettoyage des échangeurs à éléments rotatifs.	Reinigungssystem der Züge mit Drehspindeln	Sistema de limpieza de los intercambiadores con elementos giratorios
	Valvola di sicurezza	Safety valve	Soupape de sécurité	Sicherheitsventil	Válvula de seguridad
	Circolatore a controllo elettronico	Electronically controlled pump	Circulateur à commande électronique	Elektronisch gesteuerter Zirkulator	Circulador controlado electrónicamente
	Kit circolatore optional	Circulator kit optional	Kit de circulation optionnel	Zirkulator Kit optional	Kit de circulación opcional
	Valvola motorizzata	Motorized valve	Vanne motorisée	Motorisiertes Ventil	Válvula motorizada
	Sistema ACS. Acqua calda ad uso sanitario	DHW system for domestic hot water	Système ECS. Eau chaude sanitaire	ACS-System zur Brauchwasserbereitung	Sistema ACS, agua caliente para uso sanitario
	Funzione antigelo	Anti-freeze function	Fonction de sécurité antigel	Frostschutzfunktion	Anticongelación
	Convogliatore	Conveyor	Convoyeur	Förderschnecke	Conducto
	Sicurezza	Safety	Sécurité	Sicherheitsventil	Seguridad
	Telecomando con LCD Touch e funzione Multicomfort	Remote control with touch LCD and Multicomfort function	Télécommande avec LCD Touch et fonction Multicomfort	Fernbedienung mit LCD-Touch-Display und Multicomfort-Funktion	Mando a distancia con LCD táctil y función Multicomfort
	Gestione da remoto con sms o App	Remote control via text or App	Gestion à distance par Sms ou App	Fernverwaltung per SMS oder App	Gestión a distancia por Sms y App
	Kit per il prelievo dell'aria comburente dall'esterno	Kit for outdoor combustion air intake	Kit de prélèvement de l'air comburant à l'extérieur	Kit für die Verbrennungsluft-Zuführung von außen	Kit para toma del aire comburente del exterior

## Characteristics

	Scarico fumi Posteriore	Rear flue outlet	Sortie des fumées par l'arrière	Rauchabzug hinten	Salida de humos posterior
	Scarico fumi laterale	Side flue gas outlet	Évacuation des fumées latérale	Seitlicher Rauchabgang	Salida de humos lateral
	Scarico fumi superiore	Upper flue gas outlet	Sortie des fumées supérieure	Rauchabgang oben	Salida de humos superior
	Kit vaso aperto optional	Optional open tank kit	Vase d'expansion ouvert en option	Sicherheitsanforderungen offenem Ausdehnungsgefäß	Kit Seguridad vaso abierto
	Kit vaso chiuso optional	Optional closed tank kit	Vase d'expansion fermé en option	Sicherheitsanforderungen geschlossenem Ausdehnungsgefäß	Kit Seguridad vaso cerrado
	Display con sensore optional	Display with optional sensor	Display avec capteur en option	Display mit optionalem Sensor	Display con sensor opcional
	Kit piedini regolabili optional	Optional adjustable feet kit	Option pieds réglables	Optional verstellbares Fußset	Kit pies regulables opcional
	Kit piedini livellanti optional	Optional levelling feet	Pieds de nivellement	Optional Nivellierfüße-Bausatz	Kit pies niveladores opcional
	Kit cooking pro optional	Optional cooking pro kit	Option kit cooking pro	Kit cooking pro optional	Kit cooking pro opcional
	Termometro	Termometer	Thermomètre	Thermometer	Termómetro
	Forno per cottura pietanze con termostato	Cooking oven with thermostat	Four de cuisson avec thermostat	Backofen zum Zubereiten von Gerichten mit Thermostat	Horno con termostato para la cocción de alimentos
	Area cottura	Cooking area	Surface de cuisson	Kochbereich	Area cocción
	Braciere portalegna optional	Optional log grate	Berceau à buches en optionnel	Holzlagerungs-Kit optional	Brasero portaleña opcional
	Aspiracenero dedicato alla pulizia del focolare optional	Optional ash vacuum cleaner	Aspirateur de cendres optionnel	Aschestaubsauger zur Reinigung des Gerätes optional	Aspirador de ceniza para limpieza monobloque opcional

# Index

L'ampia gamma di focolari Piazzetta è in grado di soddisfare tutte le necessità di impiego. Alla scelta tra la legna ed il pellet come combustibile si aggiungono le modalità di riscaldamento: a convezione naturale, Multifuoco®, Thermo.

**EN** The extensive range of Piazzetta fireboxes is able to satisfy any usage need. Customers can choose between wood and pellets as the fuel, or even the heating mode: natural convection, Multifuoco®, Thermo.

**FR** La large gamme de foyers Piazzetta est en mesure de répondre à tous les besoins. Au choix du bois ou des granulés s'ajoute le choix du mode de chauffage : convection naturelle, Multifuoco®, Thermo.

**DE** Die große Auswahl der Piazzetta Feuerräume erfüllt alle Einsatzanforderungen. Zur Entscheidung zwischen Holz- und Pelletfeuerung kommen die Heizbetriebsarten hinzu: mit Naturkonvektion, Multifuoco®, Thermo.

**ES** La amplia gama de hogares Piazzetta satisface todas las necesidades de uso. A la elección entre leña y pellets como combustible se añaden las modalidades de calefacción: por convección natural, Multifuoco®, Thermo.

## Rivestimenti Surrounds

ABERDEEN	p.36	LANCASTER	p.154
ACADEMY	p.100	LEEDS	p.144
ADELAIDE	p.50	LIFE	p.138
AMBURGO	p.70	LINZ	p.54
ARCHEO	p.166	LIPSIA	p.68
BARCELLONA	p.150	LITHOS	p.174
BERNA	p.26	LUBECCA	p.84
BREMA	p.82	LUGANO	p.24
BRISTOL	p.42	MELBOURNE	p.48
BRISTOL con panca - with bench	p.40	MOOD	p.128
CALAIS	p.96	NEW ORLEANS	p.92
CAMBRIDGE	p.120	NEWPORT	p.30
CANBERRA	p.44	PALEO	p.172
CAPITAL	p.114	PERTH	p.152
CARDIFF	p.38	PHILADELPHIA	p.58
CHESTER	p.118	PHOENIX	p.76
CITY	p.64	PORTALE	p.162
CLASS	p.110	PRESTON	p.52
COLONIA	p.90	SALISBURGO	p.78
COLORADO	p.94	SAN DIEGO	p.116
COLUMBIA	p.60	SHEFFIELD	p.122
CRUISE	p.130	SHUTTLE	p.140
DARWIN	p.46	SHUTTLE 1	p.136
DAVOS	p.28	SIGNS	p.74
DERBY	p.160	SUN	p.98
DOGE	p.148	SURFACE	p.124
DRESDA	p.86	VIENNA	p.80
EASY	p.66	VILLAGE	p.62
EDINBURGH	p.32	VISION	p.106
EOS	p.168	VOYAGER	p.108
ESSEN	p.88	WAYS	p.170
FENICE	p.146	WITH YOU	p.134
FORUM	p.102	YORK	p.158
FOX	p.126	YORK con mensola - with shelf	p.156
FOX 1	p.132	ZEUS	p.112
FREE	p.142		
FRIBURGO	p.72		
GALLERY	p.104	TABELLE COMPATIBILITÀ	p.240
GRAZ	p.56	<b>EN</b> Compatibility tables	
HOBART	p.22	<b>FR</b> Tableaux de compatibilité	
KENSINGTON	p.34	<b>DE</b> Kompatibilitätstabellen	
KOSMOS	p.164	<b>ES</b> Tablas de compatibilidad	

## Focolari e inserti a legna Wood-burning fireboxes and inserts

MC BL	p.196
Focolari in Aluker® con anta basculante Aluker® fireboxes with tilting door	
MC SL	p.198
Focolari in Aluker® con anta saliscendi Aluker® fireboxes with Rise N' Fall door	
MC	p.200
Focolari in Aluker® Aluker® fireboxes	
MA SL	p.203
Focolari in Aluker® e ghisa con anta saliscendi Aluker® and cast-iron fireboxes with Rise N' Fall door	
MA	p.210
Focolari in Aluker® e ghisa Aluker® and cast-iron fireboxes	
HT	p.214
Focolari High Technology High Technology Fireboxes	
MT	p.236
Focolari Thermo Thermo fireboxes	
IL	p.222
Inserti Inserts	
<b>Focolari e inserti a pellet Pellet-burning fireboxes and inserts</b>	
MP	p.226
Focolari in ghisa Cast-iron fireboxes	
MP TH	p.238
Focolari Thermo Thermo fireboxes	
IP	p.229
Inserti Inserts	
COTTURA - COOKING	p.220

**GRUPPO  PIAZZETTA**

Via Montello, 22 - 31011 Casella d'Asolo (TV) Italy  
tel. +39 0423 5271 - fax +39 0423 55178  
[www.piazzetta.it](http://www.piazzetta.it) - [info@piazzetta.it](mailto:info@piazzetta.it)  
☎ 800-842026

